

**AMENDED AGENDA
REGULAR MEETING OF THE BOARD OF COMMISSIONERS
HUMBOLDT BAY HARBOR, RECREATION AND CONSERVATION DISTRICT**

DATE: June 11, 2026

TIME: Closed Session – 5:30 P.M.
Regular Session – 6:00 P.M.

PLACE: Woodley Island Marina Meeting Room, 601 Startare Drive, Eureka, CA 95501

How to Observe and Participate in the Meeting:

- **In Person** – Members of the public may observe and participate in the meeting by attending in person at Woodley Island Marina Meeting Room, 601 Startare Drive, Eureka, CA 95501.
- **Virtually** – Members of the public may observe and participate in the meeting virtually using the Zoom platform. Please note that any technical issues, regardless of cause, that prevents or delays public observation or participation via virtual means is not a basis to stop or delay the meeting, and, for this reason, members of the public should prioritize in-person attendance.

Zoom link: <https://us02web.zoom.us/j/6917934402>

Meeting ID: 691 793 4402

One tap mobile

(669) 900-9128, 6917934402#

The Humboldt Bay Harbor, Recreation and Conservation District is committed to providing equal access to all District programs, services, and activities by providing accommodations for individuals with qualified disabilities as required under the Americans with Disabilities Act. With 72 hours prior notice, a request for reasonable accommodation or modification can be made. Please contact the Clerk of the Board at (707) 443-0801 or by email at mhiley@humboldtby.org

1. Call to Order Closed Session at 5:30 P.M.

2. Public Comment

Note: This portion of the Agenda allows the public to speak to the Board on the closed session items. Each speaker is limited to speak for a period of three (3) minutes regarding each item on the Closed Session Agenda. The three (3) minute time limit may not be transferred to other speakers. The three (3) minute time limit for each speaker may be extended by the President of the Board of Commissioners or the Presiding Member of the Board of Commissioners.

Agenda for Regular Board Meeting on June 11, 2026

3. Move to Closed Session

- a) CONFERENCE WITH REAL PROPERTY NEGOTIATORS. Property: Assessor's Parcel Numbers 401-112-021 and 401-112-024, Samoa Peninsula, Humboldt County, California District negotiators: Chris Mikkelsen, Executive Director; Ryan Plotz, District Counsel. Negotiating party: California Marine Investments LLC. Under negotiation: price and terms of payment.

4. Call to Order Regular Session at 6:00 P.M. and Roll Call

5. Pledge of Allegiance

6. Report on Closed Session

7. Public Comment

*Note: This portion of the Agenda allows the public to speak to the Board on the **various issues NOT itemized on this Agenda.** A member of the public may also request that a matter appearing on the Consent Calendar be pulled and discussed separately. Pursuant to the Brown Act, the Board may not take action on any item that does not appear on the Agenda. Each speaker is limited to speak for a period of three (3) minutes regarding each item on the Agenda. Each speaker is limited to speak for a period of three (3) minutes during the PUBLIC COMMENT portion of the Agenda regarding items of special interest to the public NOT appearing on the Agenda that are within the subject matter jurisdiction of the Board of Commissioners. The three (3) minute time limit may not be transferred to other speakers. The three (3) minute time limit for each speaker may be extended by the President of the Board of Commissioners or the Presiding Member of the Board of Commissioners at the regular meeting of the District.*

8. Consent Calendar

- a) Adopt Minutes for Regular Board Meeting on April 9, 2026
- b) Receive District Financial Reports for March and April 2026
- c) Approve Purchase Order 2436 to Boatswains Locker

9. Communications, Reports, and Correspondence Received

- a) Correspondence Received
- b) Executive Director's Report
- c) Staff Reports
- d) District Counsel Report
- e) District Treasurer Report
- f) District Engineer Report
- g) District Planner Report
- h) Commissioner and Committee Reports

10. Unfinished Business

a) Receive Status Update Regarding the Humboldt Bay Offshore Wind Heavy Lift Marine Terminal Project

Recommendation: Receive the report and provide direction.

Summary: The Board has requested a monthly update regarding the Humboldt Bay Offshore Wind Heavy Lift Marine Terminal Project. This report will provide an update for June 2026. This month's update will focus on technical speakers, a review of the status of dredge material testing, and project schedule.

11. New Business

a) Consider Adopting Resolution 2026-06, A Resolution Commending Captain John Powell for His Service as a Bar Pilot on Humboldt Bay

Recommendation: Staff recommends that the Board Adopt Resolution 2026-06 and recognize Captain John Powell for his 39 years of service as a Bar Pilot on Humboldt Bay.

Summary: Captain John Powell's remarkable journey from a Deckhand to Chief Bar Pilot is a testament to his dedication, skill, and deep commitment to Humboldt Bay. His illustrious career, impeccable performance record, and passion for mentorship leave a lasting legacy that will safely guide the next generation of mariners.

b) Consider Adopting Resolution 2026-07, A Resolution Authorizing Adoption of the Humboldt County Operational Area Hazard Mitigation Plan 2025 Update

Recommendation: Staff recommends that the Board: Approve Resolution 2026-07 to adopt the Humboldt County Operational Area Hazard Mitigation Plan 2025 Update.

Summary: The Harbor District partnered with the County of Humboldt, Cities, Towns, Tribes and other Special Districts to pool resources and create consistent mitigation strategies within the Humboldt County Operational Area. Adoption of the Humboldt County Operational Area Hazard Mitigation Plan 2025 Update affirms the Harbor District's commitment to this effort and makes the Harbor District eligible for future hazard mitigation funding opportunities.

c) Consider Approving Resolution 2026-08 Adopting an Initial Study/Mitigated Negative Declaration, A Mitigation Monitoring and Reporting Program, and Establishing Findings Relative to and Approving Harbor District Permit 2023-04 with Conditions for the Humboldt Bay Oyster Company Shellfish Farm

Recommendation: Staff recommends that the Board receive a staff report, receive public comment, and adopt Harbor District Resolution No. 2026-08 which includes:

- Establishing Findings Relative to and Adopting an Initial Study/Mitigated Negative Declaration and Mitigation Monitoring and Reporting Program for the Humboldt Bay Oyster Company Shellfish Farm

Agenda for Regular Board Meeting on June 11, 2026

- Approving Permit 2023-04 with conditions for the Humboldt Bay Oyster Company Shellfish Farm

Summary: Humboldt Bay Oyster Company currently farms Pacific oysters (*Crassostrea gigas*) and Kumamoto oysters (*Magallana sikimea*) to maturity as well as Manila clams (*Venerupis philippinarum*) for seed in Humboldt Bay, California. The proposed project seeks approval for (1) its existing FLUPSY at Woodley Island Marina, raft culture in Mad River Slough, and rack and bag culture methods within existing 17.8 acre farming area in north Humboldt Bay, (2) farming within two proposed expansion areas near-by; the total footprint of shellfish culture within the two expansion areas will not exceed three acres; and (3) the use of longline culture at existing and proposed expansion sites.

~~d) Accept the Audit Report for the 2024-2025 Fiscal Year~~

Recommendation: ~~Staff recommends the Board accept the audit report for the 2024-2025 Fiscal Year.~~

Summary: ~~Harshwal & Company LLP prepared the independent auditors report for the fiscal year ending June 30th, 2025. See page 23 of the Audit for detailed information on restricted cash balances for the Dredge Surcharge and the Float Replacement Surcharge.~~

e) Authorize the Release of an RFP for the Construction and Installation of Certain Components of a Stormwater Pretreatment System to be Installed at the Fields Landing Boat Yard

Recommendation: Staff recommends that the Board authorize the Release of an RFP for the construction and installation of certain components of a Stormwater Pretreatment System to be installed at the Fields Landing Boat Yard.

Summary: The Fields Landing Boat Yard's regulated stormwater has been in exceedance status of annual volumes resulting from the vessel repair and maintenance activities that occur on site. While additional best management practices and pretreatment systems have been deployed, the actions are not bringing the site into full compliance with the Industrial General Permit, and construction of a pretreatment system is necessary.

f) Consideration of Fiscal Year 2026-2027 Budget and Preliminary Goals for Redwood Marine Terminal I, Redwood Marine Terminal II, and Shelter Cove

Recommendation: Staff recommends that the Board direct staff to implement the 2026-2027 Fiscal Year Budget Preparation Schedule and receive a report on the proposed capital expense projects for Redwood Marine Terminal I, Redwood Marine Terminal II, and Shelter Cove.

Summary: Beginning at the April 9th meeting, staff presented the capital expense projects under consideration for the 2026-2027 fiscal year and the projected costs of each. These items do not include the recurring maintenance and operations costs,

Agenda for Regular Board Meeting on June 11, 2026

which will be presented in the final budget brought to the commission for approval in July.

g) Preliminary Budget Adoption for Fiscal Year 2026-27

Recommendation: Consider adoption of the 2026-27 Preliminary Budget and set a hearing date for the adoption of the 2026-27 Final Budget.

Summary: The Budget is prepared annually under the direction of the Executive Director. In accordance with CA Harbors and Navigation Code Section 6093, on or before June 15, the District Board shall estimate and determine the amount of money required by the Harbor District and shall adopt a preliminary budget. Per Section 6093.3, the final budget shall be reported to the Board of Supervisors not later than August 1st.

12. Adjournment

**DRAFT MINUTES
REGULAR MEETING OF THE BOARD OF COMMISSIONERS
HUMBOLDT BAY HARBOR, RECREATION AND CONSERVATION DISTRICT**

April 9, 2026

The Humboldt Bay Harbor, Recreation and Conservation District met in regular session on the above date, Closed Session met at 5:30 P.M. and Regular Session met at 6:00 P.M. at the Woodley Island Marina meeting room, 601 Startare Drive, Eureka, CA 95501.

CLOSED SESSION – 5:30 P.M.

PUBLIC COMMENT: The following individuals addressed the Commission regarding subject matters on the closed session meeting agenda: No one.

BUSINESS

- a) CONFERENCE WITH REAL PROPERTY NEGOTIATORS. Property: Assessor’s Parcel Numbers 401-112-021 and 401-112-024, Samoa Peninsula, Humboldt County, California District negotiators: Chris Mikkelsen, Executive Director; Ryan Plotz, District Counsel. Negotiating party: California Marine Investments LLC. Under negotiation: price and terms of payment.

REGULAR SESSION – 6:04 P.M.

ROLL CALL

PRESENT: BENSON
 DALE
 KULLMANN
 NEWMAN
 NORTON

ABSENT: NONE

QUORUM: YES

PLEDGE OF ALLEGIENCE

REPORT ON CLOSED SESSION: No reportable action.

PUBLIC COMMENT: The following individuals addressed the Commission regarding subject matters not on the regular session meeting agenda: Sebastian Elrite, and Kevin McKernan.

CONSENT CALENDAR

- a) Adopt Minutes for Regular Board Meeting on March 12, 2026
- b) Receive District Financial Reports for February 2026
- c) Approve Purchase Order 2406 for Scribble Software
- d) Approve Purchase Order 2407 for Gelinax James

Draft Minutes for April 9, 2026 Regular Board Meeting

- e) Charter Agreement Renewal for Eric Justesen dba 707 Sportfishing to Operate a Charter Service at Woodley Island Marina
- f) Charter Agreement Renewal for Reef Twibell dba Humboldt Sportfishing to Operate a Charter Service at Woodley Island Marina
- g) Charter Agreement Renewal for Michael Stratman dba Redwood Coast Fishing to Operate a Charter Service at Woodley Island Marina
- h) New Charter Agreement for Jake McMaster dba The Captains Catch to Operate a Business at Woodley Island Marina

COMMISSIONER NEWMAN MOVED ACCEPT CONSENT CALENDAR ITEMS A-H.

COMMISSIONER DALE SECONDED.

VOICE VOTE WAS CALLED, MOTION CARRIED WITHOUT DISSENT

Ayes: BENSON, DALE, KULLMANN, NEWMAN, NORTON

Noes: NONE

Absent: NONE

Abstain: NONE

COMMUNICATIONS, REPORTS AND CORRESPONDENCE RECEIVED

- a) Correspondence Received
 - I. None received.
- b) Executive Director's Report
 - I. Executive Director presented Executive Director's report.
- c) Staff Reports
 - I. Staff presented a report.
- d) District Counsel Report
 - I. No report.
- e) District Treasurer Report
 - I. No report.
- f) District Engineer Report.
 - I. District Engineer presented a report.
- g) District Planner Report
 - I. District Planner presented a report.
- h) Commissioner and Committee Reports
 - I. Commissioners reported on recent activities and subcommittees.

UNFINISHED BUSINESS

- a) **Receive Status Update Regarding the Humboldt Bay Offshore Wind Heavy Lift Marine Terminal Project**
 - I. District staff presented the item with Josh Singer and Shelly Anghera from Moffat & Nichol.
 - II. The Commission discussed the item.
 - III. Chair Kullmann opened the item to public comment. Robin Grey-Stewart, Amy Jester, and Ted Kuiper commented.
 - IV. Chair Kullmann moved the discussion back to the Commission.
 - V. Discussion item only, no formal action was taken.

NEW BUSINESS

a) Consideration of Initial Fiscal Year 2026-2027 Budget Preparation Step 1 - Preliminary Goals for Woodley Island Marina, Fields Landing Boat Yard, and Related Dredging

- I. Executive Director presented the item.
- II. The Commission discussed the item.
- III. Chair Kullmann opened the item to public comment. No one commented.
- IV. Chair Kullmann moved the discussion back to the Commission.
- V. Discussion item only, no formal action was taken.

b) Authorize the Executive Director to Amend the Not-To-Exceed Amount for the current Moffat & Nichol Contract from \$10,819,388 to \$12,175,242 to Incorporate Remaining Funds from CEC Grant OSW-21-001 and extend the end date to April 31, 2027

- I. Executive Director presented the item.
- II. The Commission discussed the item.
- III. Chair Kullmann opened the item to public comment. No one commented.
- IV. Chair Kullmann moved the discussion back to the Commission.

COMMISSIONER DALE MOVED TO AMEND THE NOT-TO-EXCEED AMOUNT FOR THE CURRENT MOFFAT & NICHOL CONTRACT FROM \$10,819,388 TO \$12,175,242 TO INCORPORATE REMAINING FUNDS FROM CEC GRANT OSW-21-001 AND EXTEND THE END DATE TO APRIL 31, 2027.

COMMISSIONER BENSON SECONDED.

VOICE VOTE WAS CALLED, MOTION CARRIED WITHOUT DISSENT.

Ayes: BENSON, DALE, KULLMANN, NEWMAN, NORTON

Noes: NONE

Absent: NONE

Abstain: NONE

ADJOURNMENT – 8:00 P.M.

APPROVED BY:

RECORDED BY:

Aaron Newman
Secretary of the Board of Commissioners

Mindy Hiley
Director of Administrative Services

HUMBOLDT BAY HARBOR, RECREATION, AND CONSERVATION DISTRICT

Monthly Cash Flow Analysis

For The Months Ended March 31, 2026 and February 28, 2026

	<u>3/31/26</u>	<u>2/28/26</u>
<u>Account Balances</u>		
Checking	\$ 56,946	\$ 100,134
Savings	831,152	598,599
County Treasury	1,155,941	1,148,202
Cash on hand	1,181	6,214
Total Cash	<u>2,045,220</u>	<u>1,853,149</u>
Less: Restricted cash for Marina surcharges	(1,008,219)	(980,672)
Less: Estimated unexpended grant proceeds and Nordic deposits included in cash above	(636,019)	(550,668)
Cash Available (Deficit), excluding unexpended grant proceeds and deposits	<u>400,982</u>	<u>321,809</u>
 <u>Change in Cash Balance</u>		
Balance, Beginning of Month	\$ 1,853,149	\$ 1,883,383
Monthly Deposits	535,401	252,528
Monthly Payments	(343,330)	(282,762)
Balance, End of Month	<u>\$ 2,045,220</u>	<u>\$ 1,853,149</u>
 <u>Monthly Expenses Summary</u>		
Significant Individual Expenses:		
Moffat & Nichol expenditure	\$ 40,742	
Redwood Community Action Agency		\$ 58,643
Sub-total, Significance/Unusual Expenses	<u>40,742</u>	<u>58,643</u>
General operating expenses and other misc. expense	<u>302,588</u>	<u>224,119</u>
Total Cash Payments	<u>\$ 343,330</u>	<u>\$ 282,762</u>
 <u>Monthly Deposits Summary</u>		
Significant Individual Revenues:		
CalTrans - Tulutwat Spartina	\$ 301,096	
CalTrans - Eelgrass project	29,771	
Chevron Products payment		\$ 22,866
Terraphase Engineering Inc		20,240
Sub-total, Significant/Unusual Revenues	<u>330,867</u>	<u>43,106</u>
General revenues	<u>204,534</u>	<u>209,422</u>
Total Cash Receipts	<u>\$ 535,401</u>	<u>\$ 252,528</u>

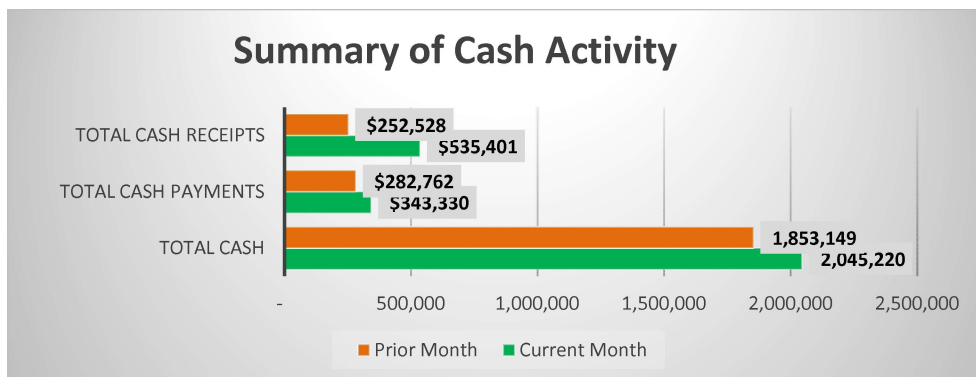

HUMBOLDT BAY HARBOR, RECREATION, AND CONSERVATION DISTRICT

Monthly Cash Flow Analysis

For The Months Ended April 30, 2026 and March 31, 2026

	<u>4/30/26</u>	<u>3/31/26</u>
<u>Account Balances</u>		
Checking	\$ 379,566	\$ 56,946
Savings	1,182,975	831,152
County Treasury	1,155,941	1,155,941
Cash on hand	1,170	1,181
Total Cash	<u>2,719,652</u>	<u>2,045,220</u>
Less: Restricted cash for Marina surcharges	(1,030,628)	(1,008,219)
Less: Estimated unexpended grant proceeds and Nordic deposits included in cash above	<u>(1,239,874)</u>	<u>(636,019)</u>
Cash Available (Deficit), excluding unexpended grant proceeds and deposits	<u><u>449,150</u></u>	<u><u>400,982</u></u>
<u>Change in Cash Balance</u>		
Balance, Beginning of Month	\$ 2,045,220	\$ 1,853,149
Monthly Deposits	1,187,275	535,401
Monthly Payments	<u>(512,843)</u>	<u>(343,330)</u>
Balance, End of Month	<u><u>\$ 2,719,652</u></u>	<u><u>\$ 2,045,220</u></u>
<u>Monthly Expenses Summary</u>		
Significant Individual Expenses:		
Moffat & Nichol expenditure	\$ 209,267	\$ 40,742
Redwood Community Action Agency	77,353	-
Sub-total, Significance/Unusual Expenses	<u>286,620</u>	<u>40,742</u>
General operating expenses and other misc. expense	<u>226,223</u>	<u>302,588</u>
Total Cash Payments	<u><u>\$ 512,843</u></u>	<u><u>\$ 343,330</u></u>
<u>Monthly Deposits Summary</u>		
Significant Individual Revenues:		
California Energy Commission	\$ 1,025,493	-
CalTrans - Tulutwat Spartina	-	\$ 301,096
CalTrans - Eelgrass project	-	29,771
Sub-total, Significant/Unusual Revenues	<u>1,025,493</u>	<u>330,867</u>
General revenues	<u>161,782</u>	<u>204,534</u>
Total Cash Receipts	<u><u>\$ 1,187,275</u></u>	<u><u>\$ 535,401</u></u>

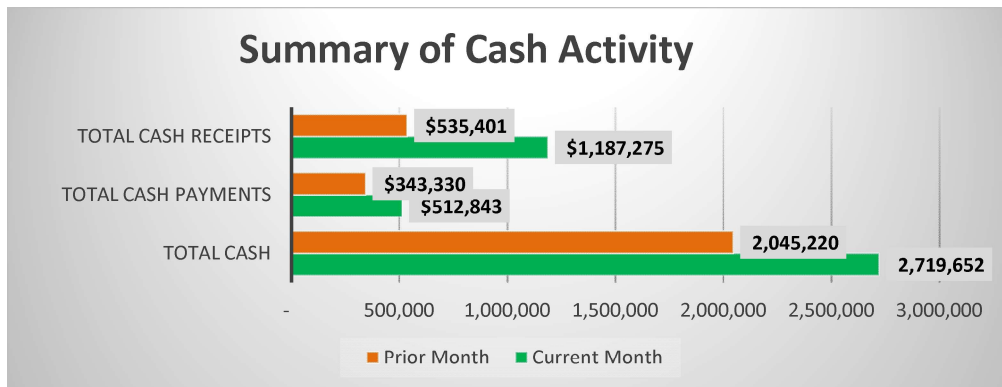

Humboldt Bay Harbor, Recreation & Conservation Dis

Balance Sheet As of March 31, 2026

	TOTAL
ASSETS	
Current Assets	
Bank Accounts	
10000 PETTY CASH ON HAND	150.00
10100 CHANGE FUND ON HAND	300.00
10111 COIN MACHINE FUND	730.00
10200 CASH IN BANK, CHECKING	36,397.06
10200.1 Cash in PNC, Checking	20,550.82
10400 CASH IN COUNTY - FUND 2720	1,116,190.22
10500 CASH IN COUNTY - FUND 3872	39,750.43
10600.1 Cash in bank, Tariff PNC	763,537.06
10700.1 Cash in bank, Water PNC	67,614.49
10901 UNEXPENDED MARINA SURCHARGES	1,008,218.97
10902 UNEXP SURCHARGES AVAIL CASH ADJ	0.00
10903 RESTRICTED CASH	-1,008,218.97
Total Bank Accounts	\$2,045,220.08
Accounts Receivable	
12000 ACCTS RECEIVABLE	2,248,362.32
Total Accounts Receivable	\$2,248,362.32
Other Current Assets	
11200 US TREASURY BONDS	0.00
12001 OTHER RECEIVABLES	0.00
12002 DOUBTFUL ACCOUNTS RECEIVABLE	0.00
12100 ALLOW FOR BAD DEBTS	0.00
12200 TAXES RECEIVBLE	0.00
12300 INTEREST RECEIVBLE	0.00
12600 Note Receivable - NMTC	0.00
12650 Note Receivable - HBDA	9,145.45
12700 PREPAID EXPENSES	58,969.48
12750 Refunds Receivable	0.00
12800 LEASE RECEIVABLE	0.00
12900 Accounts Receivable FSM	0.00
1499 Undeposited Funds	1.10
Total Other Current Assets	\$68,116.03
Total Current Assets	\$4,361,698.43
Fixed Assets	
14800 SHIPWRECK PROPERTY	50,088.05
14900 DOG RANCH PROPERTY	7,507.70
16999 Combined Expense Pending Transf	0.00

Humboldt Bay Harbor, Recreation & Conservation Dis

Balance Sheet

As of March 31, 2026

	TOTAL
CAPITAL ASSETS, NET	
14910 SAMOA PROPERTY	208,149.00
14930 TOWN OF SAMOA PROPERTY	3,007,851.23
14940 BAY STREET PROPERTY	35,000.00
15000 AUTOMOTIVE EQUIPMENT	95,639.08
15100 OFFICE EQUIPMENT	193,303.88
15200 OPERATING EQUIPMENT	314,098.74
15400 1998 MARINA DREDGING PROJECT	0.00
15500 MARINA, RESTAURANT COMPLEX	0.00
15600 MARINA	10,529,004.29
15700 FL BOAT BLDG & REPAIR FACILITY	4,302,259.53
15800 SHELTER COVE	2,386,247.10
15900 DREDGING COSTS	215,226.78
16000 KING SALMON	15,143.99
16100 MARINA DREDGE,CONSTR IN PROGRES	5,056,597.48
16400 REDWOOD DOCK PROPERTY	3,010,194.30
16500 HOMELAND SECURITY EQUIPMENT	2,254,007.60
16600 TABLE BLUFF LIGHTHOUSE	361.44
16700 AQUAPONICS PILOT FACILITY	96,036.61
16800 REDWOOD TERMINAL 2	4,941,769.69
16900 Dredge	1,215,423.27
17000 ACCUMULATED DEPRECIATION	-20,665,601.17
Total CAPITAL ASSETS, NET	17,210,712.84
Total Fixed Assets	\$17,268,308.59
Other Assets	
12400 BNY LOAN RECEIVBLE	0.00
15300 CONSTRUCTION IN PROGRESS	4,622,768.33
18000 DEPOSITS	0.00
18500 OTHER DEFERRED ASSETS	0.00
18700 Deferred Lease Asset	2,950,006.00
19000 Deferred Outflows of PERS	482,524.00
Total Other Assets	\$8,055,298.33
TOTAL ASSETS	\$29,685,305.35
LIABILITIES AND EQUITY	
Liabilities	
Current Liabilities	
Accounts Payable	
20000 ACCOUNTS PAYABLE	342,850.43
Total Accounts Payable	\$342,850.43
Credit Cards	
20112 US Bank Visa	9,215.62
Total Credit Cards	\$9,215.62

Humboldt Bay Harbor, Recreation & Conservation Dis

Balance Sheet

As of March 31, 2026

	TOTAL
Other Current Liabilities	
20000.1 ACCOUNTS PAYABLE YR END ADJUST	0.00
20100 LEASE PAYABLE TO HBDA	0.00
20200 NOTES PAYABLE	190,571.30
20400 ACCRUED WAGES PAYABLE	38,925.89
20500 ACCRUED INTEREST	47,120.00
20600 ACCRUED VACATION PAYABLE	58,871.69
20700 ACCRUED SICK LEAVE PAYABLE	60,579.54
20800 DEPOSITS ON HAND	0.00
20801 KEY DEPOSITS ON HAND	19,800.00
20802 PLUG DEPOSITS ON HAND	1,430.00
20803 SLIP DEPOSITS ON HAND	57,086.24
20804 STORAGE DEPOSITS	4,409.15
20805 CONF. ROOM DEPOSITS	0.00
20806 LEASE SECURITY DEPOSIT	95,123.92
20807 STORAGE DEPOSIT - REDWOOD DOCK	2,943.31
20808 WAIT LIST DEPOSIT	6,825.00
20809 HAUL OUT DEPOSIT	0.00
Total 20800 DEPOSITS ON HAND	187,617.62
22000 DEFERRED LEASE INCOME	0.00
24000 Ground Lease Deferred Income	0.00
24002 Groundlease Current Def Income	0.00
27201 Deferred Inflows - OPEB	10,067.00
28000 DEFERRED INCOME	163,198.42
28400 DEFERREDINCOMECalTrans Spartina	596,444.94
28402 DEFERREDINCOME CalTrans Eelgrass	14,576.64
28404 DEFERRED INCOME - OWS	878,890.50
28500 OTHER DEFERRED CREDITS	0.00
Payroll tax & Withholding Liab	
2100 PAYROLL LIABILITIES	0.00
21000 WAGE GARNISHES	0.00
2110 DIRECT DEPOSIT LIABILITIES	0.00
21100 FEDERAL WITHHOLDING TAX	0.00
2111 *DIRECT DEPOSIT LIABILITIES	0.00
21200 STATE WITHHOLDING TAX	0.00
21300 STATE UNEMPLOYMENT TAX	1,830.28
21400 SOCIAL SECURITY/MEDICARE TAX	0.00
21500 AFLAC	0.00
21600 PERS CARE/MEDICAL INSURANCE	0.00
21700 PERS RETIREMENT	0.00
21701 PERS DEFERRED COMPENSATION	0.00
21800 STATE DISABILITY INSURANCE	0.00
21900 UNION DUES DEDUCTIBLE	0.00

Humboldt Bay Harbor, Recreation & Conservation Dis

Balance Sheet

As of March 31, 2026

	TOTAL
Total Payroll tax & Withholding Liab	1,830.28
Sales Tax Agency Payable	0.00
Total Other Current Liabilities	\$2,248,693.82
Total Current Liabilities	\$2,600,759.87
Long-Term Liabilities	
24001 Gound Lease Amortization	0.00
24003 Groundlease Current Offset	0.00
25000 DUE STATE OF CALIFORNIA	0.00
25100 NOTES PAYABLE- CMIA	0.00
25200 ENVIRONMENTAL REMEDIATION LIAB	0.00
25300 BOND PAYABLE - DEEP DREDGING	0.00
25400 Note Payable - No. Valley Bank	0.00
25500 OPEB Liability	94,816.00
25600 Note Payable-Coast Seafoods Co.	0.00
25700 BOND PAYABLE 2014 REFINANCING	993,386.92
25800 BBVA Loan Payable	625,800.42
25900 LESS CURRENT PORTION	-190,571.30
26000 CAPITAL LEASE PAYABLE	0.00
26100 Rate Stabilization Fund	4,928,000.00
27000 Net Pension Liability	1,479,612.00
27200 Deferred Inflows of PERS	38,154.00
27202 Deferred Inflows - Leases	2,690,202.00
Total Long-Term Liabilities	\$10,659,400.04
Total Liabilities	\$13,260,159.91
Equity	
3000 OPENING BALANCE EQUITY	0.00
30200 GOVT CONTRIBUTIONS MARINA	0.00
30201 ACCUM DEPR MARINA, EDA PORTION	0.00
30300 GOVT CNTRB/FL BOAT BLDG/RPR FAC	0.00
30301 ACCUM DEPR - FL BOAT BLDG & RPR	0.00
30400 GOVT CONTRIB - CA DEPT OF B&W	0.00
30401 ACCUM DEPR/SHELTER COVE B&W	0.00
30500 INVESTMENT IN FIXED ASSETS	11,208,910.72
30505 Change In Invest Fixed Assets	1,327,061.24
Total 30500 INVESTMENT IN FIXED ASSETS	12,535,971.96
30900 RESTRICTED FUND BALANCE	-2,148,290.54
30901 Restricted Fd Bal-Curr Yr Chang	3,157,662.09
Total 30900 RESTRICTED FUND BALANCE	1,009,371.55

Humboldt Bay Harbor, Recreation & Conservation Dis

Balance Sheet

As of March 31, 2026

	TOTAL
31200 GENERAL FUND BALANCE	1,998,049.71
31000 FUND BALANCE - TIDELANDS TRUST	-876,282.21
31100 Designated for General Fd Reser	0.00
31108 Designated Bal-Curr Yr Change	0.00
Total 31100 Designated for General Fd Reser	0.00
31201 General Fund-Change is Restrict	-3,186,955.77
31205 General Fund Invest Fixed Asset	0.00
31208 General Fund Change in Designat	0.00
Total 31200 GENERAL FUND BALANCE	-2,065,188.27
3900 RETAINED EARNINGS	971,601.92
Net Income	3,973,388.28
Total Equity	\$16,425,145.44
TOTAL LIABILITIES AND EQUITY	\$29,685,305.35

Humboldt Bay Harbor, Recreation & Conservation Dis

Balance Sheet As of April 30, 2026

	TOTAL
ASSETS	
Current Assets	
Bank Accounts	
10000 PETTY CASH ON HAND	140.00
10100 CHANGE FUND ON HAND	300.00
10111 COIN MACHINE FUND	730.00
10200 CASH IN BANK, CHECKING	7,241.43
10200.1 Cash in PNC, Checking	372,326.03
10400 CASH IN COUNTY - FUND 2720	1,116,190.22
10500 CASH IN COUNTY - FUND 3872	39,750.43
10600.1 Cash in bank, Tariff PNC	1,160,657.46
10700.1 Cash in bank, Water PNC	22,318.00
10901 UNEXPENDED MARINA SURCHARGES	1,030,628.25
10902 UNEXP SURCHARGES AVAIL CASH ADJ	0.00
10903 RESTRICTED CASH	-1,030,628.25
Total Bank Accounts	\$2,719,653.57
Accounts Receivable	
12000 ACCTS RECEIVABLE	1,496,570.91
Total Accounts Receivable	\$1,496,570.91
Other Current Assets	
11200 US TREASURY BONDS	0.00
12001 OTHER RECEIVABLES	0.00
12002 DOUBTFUL ACCOUNTS RECEIVABLE	0.00
12100 ALLOW FOR BAD DEBTS	0.00
12200 TAXES RECEIVBLE	0.00
12300 INTEREST RECEIVBLE	0.00
12600 Note Receivable - NMTC	0.00
12650 Note Receivable - HBDA	9,145.45
12700 PREPAID EXPENSES	45,786.11
12750 Refunds Receivable	0.00
12800 LEASE RECEIVABLE	0.00
12900 Accounts Receivable FSM	0.00
1499 Undeposited Funds	0.10
Total Other Current Assets	\$54,931.66
Total Current Assets	\$4,271,156.14
Fixed Assets	
14800 SHIPWRECK PROPERTY	50,088.05
14900 DOG RANCH PROPERTY	7,507.70
16999 Combined Expense Pending Transf	0.00

Humboldt Bay Harbor, Recreation & Conservation Dis

Balance Sheet

As of April 30, 2026

	TOTAL
CAPITAL ASSETS, NET	
14910 SAMOA PROPERTY	208,149.00
14930 TOWN OF SAMOA PROPERTY	3,007,851.23
14940 BAY STREET PROPERTY	35,000.00
15000 AUTOMOTIVE EQUIPMENT	95,639.08
15100 OFFICE EQUIPMENT	193,303.88
15200 OPERATING EQUIPMENT	335,611.22
15400 1998 MARINA DREDGING PROJECT	0.00
15500 MARINA, RESTAURANT COMPLEX	0.00
15600 MARINA	10,529,004.29
15700 FL BOAT BLDG & REPAIR FACILITY	4,302,259.53
15800 SHELTER COVE	2,386,247.10
15900 DREDGING COSTS	215,226.78
16000 KING SALMON	15,143.99
16100 MARINA DREDGE,CONSTR IN PROGRES	5,056,597.48
16400 REDWOOD DOCK PROPERTY	3,010,194.30
16500 HOMELAND SECURITY EQUIPMENT	2,254,007.60
16600 TABLE BLUFF LIGHTHOUSE	361.44
16700 AQUAPONICS PILOT FACILITY	96,036.61
16800 REDWOOD TERMINAL 2	4,941,769.69
16900 Dredge	1,215,423.27
17000 ACCUMULATED DEPRECIATION	-20,733,805.17
Total CAPITAL ASSETS, NET	17,164,021.32
Total Fixed Assets	\$17,221,617.07
Other Assets	
12400 BNY LOAN RECEIVBLE	0.00
15300 CONSTRUCTION IN PROGRESS	4,974,379.85
18000 DEPOSITS	0.00
18500 OTHER DEFERRED ASSETS	0.00
18700 Deferred Lease Asset	2,950,006.00
19000 Deferred Outflows of PERS	485,000.52
Total Other Assets	\$8,409,386.37
TOTAL ASSETS	\$29,902,159.58
LIABILITIES AND EQUITY	
Liabilities	
Current Liabilities	
Accounts Payable	
20000 ACCOUNTS PAYABLE	570,626.40
Total Accounts Payable	\$570,626.40
Credit Cards	
20112 US Bank Visa	13,365.69
Total Credit Cards	\$13,365.69

Humboldt Bay Harbor, Recreation & Conservation Dis

Balance Sheet As of April 30, 2026

	TOTAL
Other Current Liabilities	
20000.1 ACCOUNTS PAYABLE YR END ADJUST	0.00
20100 LEASE PAYABLE TO HBDA	0.00
20200 NOTES PAYABLE	190,571.30
20400 ACCRUED WAGES PAYABLE	38,925.89
20500 ACCRUED INTEREST	58,900.00
20600 ACCRUED VACATION PAYABLE	58,871.69
20700 ACCRUED SICK LEAVE PAYABLE	60,579.54
20800 DEPOSITS ON HAND	0.00
20801 KEY DEPOSITS ON HAND	19,700.00
20802 PLUG DEPOSITS ON HAND	1,430.00
20803 SLIP DEPOSITS ON HAND	57,125.14
20804 STORAGE DEPOSITS	4,409.15
20805 CONF. ROOM DEPOSITS	0.00
20806 LEASE SECURITY DEPOSIT	95,123.92
20807 STORAGE DEPOSIT - REDWOOD DOCK	2,943.31
20808 WAIT LIST DEPOSIT	6,725.00
20809 HAUL OUT DEPOSIT	0.00
Total 20800 DEPOSITS ON HAND	187,456.52
22000 DEFERRED LEASE INCOME	0.00
24000 Ground Lease Deferred Income	0.00
24002 Groundlease Current Def Income	0.00
27201 Deferred Inflows - OPEB	10,067.00
28000 DEFERRED INCOME	163,198.42
28400 DEFERREDINCOMECalTrans Spartina	727,611.20
28402 DEFERREDINCOME CalTrans Eelgrass	13,487.70
28404 DEFERRED INCOME - OWS	527,278.98
28500 OTHER DEFERRED CREDITS	0.00
Payroll tax & Withholding Liab	
2100 PAYROLL LIABILITIES	0.00
21000 WAGE GARNISHES	0.00
2110 DIRECT DEPOSIT LIABILITIES	0.00
21100 FEDERAL WITHHOLDING TAX	0.00
2111 *DIRECT DEPOSIT LIABILITIES	0.00
21200 STATE WITHHOLDING TAX	0.00
21300 STATE UNEMPLOYMENT TAX	115.77
21400 SOCIAL SECURITY/MEDICARE TAX	0.00
21500 AFLAC	0.00
21600 PERS CARE/MEDICAL INSURANCE	599.94
21700 PERS RETIREMENT	0.00
21701 PERS DEFERRED COMPENSATION	0.00
21800 STATE DISABILITY INSURANCE	0.00
21900 UNION DUES DEDUCTIBLE	0.00

Humboldt Bay Harbor, Recreation & Conservation Dis

Balance Sheet As of April 30, 2026

	TOTAL
Total Payroll tax & Withholding Liab	715.71
Sales Tax Agency Payable	0.00
Total Other Current Liabilities	\$2,037,663.95
Total Current Liabilities	\$2,621,656.04
Long-Term Liabilities	
24001 Gound Lease Amortization	0.00
24003 Groundlease Current Offset	0.00
25000 DUE STATE OF CALIFORNIA	0.00
25100 NOTES PAYABLE- CMIA	0.00
25200 ENVIRONMENTAL REMEDIATION LIAB	0.00
25300 BOND PAYABLE - DEEP DREDGING	0.00
25400 Note Payable - No. Valley Bank	0.00
25500 OPEB Liability	94,816.00
25600 Note Payable-Coast Seafoods Co.	0.00
25700 BOND PAYABLE 2014 REFINANCING	993,386.92
25800 BBVA Loan Payable	625,800.42
25900 LESS CURRENT PORTION	-190,571.30
26000 CAPITAL LEASE PAYABLE	0.00
26100 Rate Stabilization Fund	4,928,000.00
27000 Net Pension Liability	1,479,612.00
27200 Deferred Inflows of PERS	38,154.00
27202 Deferred Inflows - Leases	2,690,202.00
Total Long-Term Liabilities	\$10,659,400.04
Total Liabilities	\$13,281,056.08
Equity	
3000 OPENING BALANCE EQUITY	0.00
30200 GOVT CONTRIBUTIONS MARINA	0.00
30201 ACCUM DEPR MARINA, EDA PORTION	0.00
30300 GOVT CNTRB/FL BOAT BLDG/RPR FAC	0.00
30301 ACCUM DEPR - FL BOAT BLDG & RPR	0.00
30400 GOVT CONTRIB - CA DEPT OF B&W	0.00
30401 ACCUM DEPR/SHELTER COVE B&W	0.00
30500 INVESTMENT IN FIXED ASSETS	11,208,910.72
30505 Change In Invest Fixed Assets	1,327,061.24
Total 30500 INVESTMENT IN FIXED ASSETS	12,535,971.96
30900 RESTRICTED FUND BALANCE	-2,148,290.54
30901 Restricted Fd Bal-Curr Yr Chang	3,180,071.37
Total 30900 RESTRICTED FUND BALANCE	1,031,780.83

Humboldt Bay Harbor, Recreation & Conservation Dis

Balance Sheet

As of April 30, 2026

	TOTAL
31200 GENERAL FUND BALANCE	1,998,049.71
31000 FUND BALANCE - TIDELANDS TRUST	-876,282.21
31100 Designated for General Fd Reser	0.00
31108 Designated Bal-Curr Yr Change	0.00
Total 31100 Designated for General Fd Reser	0.00
31201 General Fund-Change is Restrict	-3,209,365.05
31205 General Fund Invest Fixed Asset	0.00
31208 General Fund Change in Designat	0.00
Total 31200 GENERAL FUND BALANCE	-2,087,597.55
3900 RETAINED EARNINGS	970,942.12
Net Income	4,170,006.14
Total Equity	\$16,621,103.50
TOTAL LIABILITIES AND EQUITY	\$29,902,159.58

Humboldt Bay Harbor, Recreation & Conservation Dis

Profit and Loss

March 2026

	TOTAL	
	MAR 2026	JUL 2025 - MAR 2026 (YTD)
Income		
45912 Other Revenue - OSW	146,602.50	146,602.50
52708.1 Discount		105.04
Donations		
46519 Donations - Lighthouse		2.00
Total Donations		2.00
Dredging Revenue		
41318 Dredging Surcharge - T	21,209.57	179,351.13
Total Dredging Revenue	21,209.57	179,351.13
Fees		
40108 PERMITS-T	500.00	2,500.00
40808 Pilotage Services - T		2,179.58
41308.1 Poundage - T		30.34
41818 Late Charges/Interest - T	3,975.00	40,800.00
41819 Late Charges/Interest - NT	906.30	7,641.63
45608 Chevron - Ports O&M - T	8,087.50	24,262.50
Total Fees	13,468.80	77,414.05
Float Replacement Account		
41418 Float Replacement	6,712.07	56,577.42
Total Float Replacement Account	6,712.07	56,577.42
Grant Revenue		
Conservation Grants		
45208.3 Conservation Grants, Gov't - T		110,213.93
Total Conservation Grants		110,213.93
Harbor Grants		
45208 Harbor Grants, Other - T	4,232.34	24,472.21
45208.1 Harbor Grants, Gov't - T		4,108,964.30
Total Harbor Grants	4,232.34	4,133,436.51
Recreation Grants		
45208.2 Recreation Grants, Gov't - T		25,447.88
Total Recreation Grants		25,447.88
Total Grant Revenue	4,232.34	4,269,098.32
Harbor Surcharge		
40908 Harbor Improvement Surcharge-T	18,896.30	112,215.26
Total Harbor Surcharge	18,896.30	112,215.26
Interest Revenue		
43108 Interest Income - T	1,339.85	9,466.65
43109 Interest Income - NT	6,972.84	20,640.81

Humboldt Bay Harbor, Recreation & Conservation Dis

Profit and Loss

March 2026

	TOTAL	
	MAR 2026	JUL 2025 - MAR 2026 (YTD)
43318 Interest On Del Accts - T		504.04
Total Interest Revenue	8,312.69	30,611.50
Other Revenue		
45908 Other Revenue - T	1.10	15.20
45909 Other Revenue - NT	62,888.54	197,911.91
45911 Other Revenue - Spartina	36,312.42	612,802.91
Total Other Revenue	99,202.06	810,730.02
Rent Income		
40218 Slip Rents - T	52,881.19	444,180.95
40318.1 Transient Rentals - T	832.39	18,895.34
40518 Equipment Rent - T		3,688.04
40519 Equipment Rent - NT		1,250.00
40709 FL BUILDING SPACE RENT G/NT	3,404.85	30,643.65
40809 Yard Rent - NT	3,592.28	28,511.74
41108 Rents, Tidelands Leases - T	21,231.94	323,174.23
41309 Storage - NT	7,909.83	55,142.01
41409 Upland Rent - NT	70,173.68	637,859.96
Total Rent Income	160,026.16	1,543,345.92
Sales		
40118 SALES & PERMITS M/T	1,200.00	8,160.00
40119 Concession Sales - NT	1,479.75	7,363.05
Total Sales	2,679.75	15,523.05
Tax Revenue		
43509 Property Tax Revenues	0.00	771,056.78
45009 Other Federal Tax Revenue		14.19
Total Tax Revenue	0.00	771,070.97
Utility Surcharge		
40409 Utility Surcharge - NT	1,590.00	91,724.76
40418 Utility Surcharge, Marina Dock	5,736.62	48,315.31
Total Utility Surcharge	7,326.62	140,040.07
Total Income	\$488,668.86	\$8,152,687.25
GROSS PROFIT	\$488,668.86	\$8,152,687.25
Expenses		
57018 Bank Service Charges	425.24	4,126.06
Accounting/Auditing Services		
52500 Accounting Fees - T	4,389.00	76,095.38
52508 Accounting Fees - NT	1,463.00	28,402.12
Total Accounting/Auditing Services	5,852.00	104,497.50

Humboldt Bay Harbor, Recreation & Conservation Dis

Profit and Loss

March 2026

	TOTAL	
	MAR 2026	JUL 2025 - MAR 2026 (YTD)
Advertising & Promotion		
51000 Advertising & Promotion - NT	1,000.00	302.48
51008 Advertising & Promotion - T	442.65	614.62
Total Advertising & Promotion	1,442.65	917.10
Bad Debts		
51308 Bad Debts - T	14,275.00	14,450.00
Total Bad Debts	14,275.00	14,450.00
Communications		
51400 Communications - NT	1,056.36	10,191.64
51408 Communications - T	174.63	1,556.25
Total Communications	1,230.99	11,747.89
Conference & Meetings		
51500 Conferences & Meetings - NT	5,066.42	12,541.43
51508 Conferences & Meetings - T		249.23
Total Conference & Meetings	5,066.42	12,790.66
Depreciation		
53509 Depreciation - NT	68,204.00	613,836.00
Total Depreciation	68,204.00	613,836.00
Dredging Expense		
55608 Dredging Expense - T		40,267.00
56708 Dredging - GT	375.00	960.00
56718 Dredging - MT		
Total Dredging Expense	375.00	41,227.00
Dues, Subscriptions & Licences		
51600 Dues & Subscriptions - NT	2,845.00	28,950.31
51608 Dues & Subscriptions - T		2,553.64
Total Dues, Subscriptions & Licences	2,845.00	31,503.95
Elections & Government Fees		
51700 Elections & Prop Tax Assess-NT		21,698.86
Total Elections & Government Fees		21,698.86
Engineering Services		
52400 Engineering Fees - NT	4,863.51	35,695.51
52408 Engineering Fees - T		6,739.00
Total Engineering Services	4,863.51	42,434.51
Fuel		
51200 Automotive, Fuel- NT	400.00	6,427.77
51208 Vessel Fuel		719.23
51218 Automotive, Fuel - T		5,027.75
Total Fuel	400.00	12,174.75

Humboldt Bay Harbor, Recreation & Conservation Dis

Profit and Loss

March 2026

	TOTAL	
	MAR 2026	JUL 2025 - MAR 2026 (YTD)
Grant Expenses		
Conservation Grant Expenses		
54408.3 Conservation Grant Exp		5,242.50
Total Conservation Grant Expenses		5,242.50
Harbor Grant Expenses		
54408.1 Harbor Grant Exp	83,926.82	140,172.08
Total Harbor Grant Expenses	83,926.82	140,172.08
Recreation Grant Expenses		
54408.2 Recreation Grant Exp		0.00
Total Recreation Grant Expenses		0.00
Total Grant Expenses	83,926.82	145,414.58
Insurance		
51800 Insurance - NT	8,196.32	104,767.82
51808 Insurance - T		19,709.50
Total Insurance	8,196.32	124,477.32
Interest Expense		
55108 Interest Expense - T	4,156.00	53,569.36
55109 Interest Expense - NT	7,624.00	146,248.76
Total Interest Expense	11,780.00	199,818.12
Legal Services		
52300 Legal Fees - NT	1,177.88	43,122.77
52308 Legal Fees - T	340.62	3,926.24
Total Legal Services	1,518.50	47,049.01
Maintenance - Equipment		
51209 Automotive, Repairs - NT	35.66	3,836.65
52710 Repairs & Maint, Equip - NT	3,735.92	6,529.42
52718 Repairs & Maint, Equip - T	1,237.21	30,781.98
Total Maintenance - Equipment	5,008.79	41,148.05
Maintenance - Facilities		
52708 Repairs & Maint, Facilities - T	2,083.33	65,348.07
52719 Repairs & Maint, Facilities - N	1,559.78	27,141.82
Total Maintenance - Facilities	3,643.11	92,489.89
Maintenance - IT		
57008 Maintenance, IT Equip - T	766.50	5,708.50
57009 Maintenance, IT Equip - NT		4,838.31
Total Maintenance - IT	766.50	10,546.81

Humboldt Bay Harbor, Recreation & Conservation Dis

Profit and Loss

March 2026

	TOTAL	
	MAR 2026	JUL 2025 - MAR 2026 (YTD)
Maintenance Supplies		
52008 Maintenance Supplies - T		668.43
52010 Maintenance Supplies - NT	3,571.78	17,872.58
Total Maintenance Supplies	3,571.78	18,541.01
Office Supplies		
51900 Office Supplies - NT	5,444.46	54,214.04
51908 Office Supplies - T	388.01	4,635.70
52100 Outside Services - NT		14.32
Total Office Supplies	5,832.47	58,864.06
Other Expenses		
53709 Cash Over/Short - NT		-100.00
54405 Other Expenses - Spartina		517,261.22
55418 Other Expenses - T	2,183.00	2,183.00
55419 Other Expenses - NT		4,994.86
Total Other Expenses	2,183.00	524,339.08
Other Professional/Outside Serv		
52109 Outside Services, Other - NT	4,133.00	24,998.75
52118 Outside Services, Other - T	660.00	2,460.00
Total Other Professional/Outside Serv	4,793.00	27,458.75
Permits		
51610 Permits - NT		13,867.80
51618 Permits - T		2,811.00
Total Permits		16,678.80
Personnel Expenses		
Contract Temporary Services		
50310 Contract Temporary Services - N	9,527.14	14,584.45
Total Contract Temporary Services	9,527.14	14,584.45
Payroll Burden		
50500 Payroll Benefits, Other - NT	36,577.64	331,874.60
50508 Payroll Benefits, Other - T	8,764.66	86,000.54
6560 Workers' Comp	3,360.46	22,923.33
Total Payroll Burden	48,702.76	440,798.47
Salaries/Wages		
50100 Salaries & Wages - NT	79,283.97	847,524.12
50108 Salaries & Wages - T	0.00	0.00
Total Salaries/Wages	79,283.97	847,524.12
Total Personnel Expenses	137,513.87	1,302,907.04

Humboldt Bay Harbor, Recreation & Conservation Dis

Profit and Loss

March 2026

	TOTAL	
	MAR 2026	JUL 2025 - MAR 2026 (YTD)
Planning Services		
52200 Planning Fees - NT	4,530.00	10,010.09
52208 Planning Fees - T	3,470.00	24,784.42
Total Planning Services	8,000.00	34,794.51
Rent Expense		
52600 Rent Expense - NT	1,000.00	1,756.00
Total Rent Expense	1,000.00	1,756.00
Small Tools		
52800 Small Tools - NT		1,620.17
52808 Small Tools - T		121.26
Total Small Tools		1,741.43
Utilities		
52909 Utilities - NT	10,937.72	203,976.54
52918 Utilities - T	11,252.08	78,964.49
53000 Water, Sewer, & Refuse - NT	8,794.01	99,853.52
53008 Water, Sewer, & Refuse - T	6,282.90	52,738.70
Total Utilities	37,266.71	435,533.25
Total Expenses	\$419,980.68	\$3,994,961.99
NET OPERATING INCOME	\$68,688.18	\$4,157,725.26
Other Expenses		
Other Non-operating Expenses		
55409 OTHER EXPENSES G/NT	62,664.23	184,336.98
Total Other Non-operating Expenses	62,664.23	184,336.98
Total Other Expenses	\$62,664.23	\$184,336.98
NET OTHER INCOME	\$ -62,664.23	\$ -184,336.98
NET INCOME	\$6,023.95	\$3,973,388.28

Humboldt Bay Harbor, Recreation & Conservation Dis

Profit and Loss

April 2026

	TOTAL	
	APR 2026	JUL 2025 - APR 2026 (YTD)
Income		
Donations		
46519 Donations - Lighthouse	4.00	6.00
Total Donations	4.00	6.00
Dredging Revenue		
41318 Dredging Surcharge - T	17,535.19	196,886.32
Total Dredging Revenue	17,535.19	196,886.32
Fees		
40108 PERMITS-T		2,500.00
40808 Pilotage Services - T	606.86	2,786.44
41308.1 Poundage - T		30.34
41818 Late Charges/Interest - T	3,950.00	44,750.00
41819 Late Charges/Interest - NT	903.16	8,544.79
45608 Chevron - Ports O&M - T		24,262.50
Total Fees	5,460.02	82,874.07
Float Replacement Account		
41418 Float Replacement	5,484.09	62,061.51
Total Float Replacement Account	5,484.09	62,061.51
Grant Revenue		
Conservation Grants		
45208.3 Conservation Grants, Gov't - T		110,213.93
Total Conservation Grants		110,213.93
Harbor Grants		
45208 Harbor Grants, Other - T	1,942.05	26,414.26
45208.1 Harbor Grants, Gov't - T	6,205.36	4,115,169.66
Total Harbor Grants	8,147.41	4,141,583.92
Recreation Grants		
45208.2 Recreation Grants, Gov't - T		25,447.88
Total Recreation Grants		25,447.88
Total Grant Revenue	8,147.41	4,277,245.73
Harbor Surcharge		
40908 Harbor Improvement Surcharge-T	9,460.00	121,675.26
Total Harbor Surcharge	9,460.00	121,675.26
Interest Revenue		
43108 Interest Income - T	790.22	10,256.87
43109 Interest Income - NT	0.46	20,641.27
43318 Interest On Del Accts - T		504.04
Total Interest Revenue	790.68	31,402.18

Humboldt Bay Harbor, Recreation & Conservation Dis

Profit and Loss

April 2026

	TOTAL	
	APR 2026	JUL 2025 - APR 2026 (YTD)
Other Revenue		
45908 Other Revenue - T	5.00	20.20
45909 Other Revenue - NT	47,143.05	245,054.96
45911 Other Revenue - Spartina	22,898.99	635,701.90
45912 Other Revenue - OSW	351,611.52	498,214.02
Total Other Revenue	421,658.56	1,378,991.08
Rent Income		
40218 Slip Rents - T	43,357.81	487,538.76
40318.1 Transient Rentals - T	1,286.51	20,181.85
40518 Equipment Rent - T	1,224.93	4,912.97
40519 Equipment Rent - NT		1,250.00
40709 FL BUILDING SPACE RENT G/NT	3,404.85	34,048.50
40809 Yard Rent - NT	2,596.28	31,108.02
41108 Rents, Tidelands Leases - T	30,527.12	353,701.35
41309 Storage - NT	4,615.75	59,757.76
41409 Upland Rent - NT	70,860.22	708,720.18
Total Rent Income	157,873.47	1,701,219.39
Sales		
40118 SALES & PERMITS M/T	1,200.00	9,360.00
40119 Concession Sales - NT	493.25	7,856.30
52708.1 Discount	73.36	178.40
Total Sales	1,766.61	17,394.70
Tax Revenue		
43509 Property Tax Revenues	0.00	771,056.78
45009 Other Federal Tax Revenue		14.19
Total Tax Revenue	0.00	771,070.97
Utility Surcharge		
40409 Utility Surcharge - NT	23,886.28	115,611.04
40418 Utility Surcharge, Marina Dock	5,346.65	53,661.96
Total Utility Surcharge	29,232.93	169,273.00
Total Income	\$657,412.96	\$8,810,100.21
GROSS PROFIT	\$657,412.96	\$8,810,100.21
Expenses		
57018 Bank Service Charges	422.06	4,548.12
Accounting/Auditing Services		
52500 Accounting Fees - T	5,064.37	81,159.75
52508 Accounting Fees - NT	1,688.13	30,090.25
Total Accounting/Auditing Services	6,752.50	111,250.00

Humboldt Bay Harbor, Recreation & Conservation Dis

Profit and Loss

April 2026

	TOTAL	
	APR 2026	JUL 2025 - APR 2026 (YTD)
Advertising & Promotion		
51000 Advertising & Promotion - NT		302.48
51008 Advertising & Promotion - T		614.62
Total Advertising & Promotion		917.10
Bad Debts		
51308 Bad Debts - T		14,450.00
Total Bad Debts		14,450.00
Communications		
51400 Communications - NT	1,081.02	11,272.66
51408 Communications - T	174.63	1,730.88
Total Communications	1,255.65	13,003.54
Conference & Meetings		
51500 Conferences & Meetings - NT	1,130.73	13,672.16
51508 Conferences & Meetings - T		249.23
Total Conference & Meetings	1,130.73	13,921.39
Depreciation		
53509 Depreciation - NT	68,204.00	682,040.00
Total Depreciation	68,204.00	682,040.00
Dredging Expense		
55608 Dredging Expense - T		40,267.00
56708 Dredging - GT	610.00	1,570.00
56718 Dredging - MT		
Total Dredging Expense	610.00	41,837.00
Dues, Subscriptions & Licences		
51600 Dues & Subscriptions - NT	5,652.98	34,603.29
51608 Dues & Subscriptions - T	5,540.00	8,093.64
Total Dues, Subscriptions & Licences	11,192.98	42,696.93
Elections & Government Fees		
51700 Elections & Prop Tax Assess-NT	264.00	21,962.86
Total Elections & Government Fees	264.00	21,962.86
Engineering Services		
52400 Engineering Fees - NT	3,049.90	38,745.41
52408 Engineering Fees - T		6,739.00
Total Engineering Services	3,049.90	45,484.41
Fuel		
51200 Automotive, Fuel- NT	1,727.58	8,155.35
51208 Vessel Fuel		719.23
51218 Automotive, Fuel - T	1,344.49	6,372.24
Total Fuel	3,072.07	15,246.82

Humboldt Bay Harbor, Recreation & Conservation Dis

Profit and Loss

April 2026

	TOTAL	
	APR 2026	JUL 2025 - APR 2026 (YTD)
Grant Expenses		
Conservation Grant Expenses		
54408.3 Conservation Grant Exp		5,242.50
Total Conservation Grant Expenses		5,242.50
Harbor Grant Expenses		
54408.1 Harbor Grant Exp	75,448.37	215,620.45
Total Harbor Grant Expenses	75,448.37	215,620.45
Recreation Grant Expenses		
54408.2 Recreation Grant Exp		0.00
Total Recreation Grant Expenses		0.00
Total Grant Expenses	75,448.37	220,862.95
Insurance		
51800 Insurance - NT	12,459.61	117,227.43
51808 Insurance - T		19,709.50
Total Insurance	12,459.61	136,936.93
Interest Expense		
55108 Interest Expense - T	4,156.00	57,725.36
55109 Interest Expense - NT	7,624.00	153,872.76
Total Interest Expense	11,780.00	211,598.12
Legal Services		
52300 Legal Fees - NT		43,122.77
52308 Legal Fees - T	8,025.00	11,951.24
Total Legal Services	8,025.00	55,074.01
Maintenance - Equipment		
51209 Automotive, Repairs - NT	1,109.94	4,946.59
52710 Repairs & Maint, Equip - NT	724.32	7,253.74
52718 Repairs & Maint, Equip - T	296.89	31,078.87
Total Maintenance - Equipment	2,131.15	43,279.20
Maintenance - Facilities		
52708 Repairs & Maint, Facilities - T	10,972.75	76,320.82
52719 Repairs & Maint, Facilities - N	6,225.30	33,367.12
Total Maintenance - Facilities	17,198.05	109,687.94
Maintenance - IT		
57008 Maintenance, IT Equip - T	663.00	6,371.50
57009 Maintenance, IT Equip - NT	287.50	5,125.81
Total Maintenance - IT	950.50	11,497.31

Humboldt Bay Harbor, Recreation & Conservation Dis

Profit and Loss

April 2026

	TOTAL	
	APR 2026	JUL 2025 - APR 2026 (YTD)
Maintenance Supplies		
52008 Maintenance Supplies - T	75.06	743.49
52010 Maintenance Supplies - NT	2,904.24	20,776.82
Total Maintenance Supplies	2,979.30	21,520.31
Office Supplies		
51900 Office Supplies - NT	4,715.66	58,929.70
51908 Office Supplies - T	541.46	5,177.16
52100 Outside Services - NT		14.32
Total Office Supplies	5,257.12	64,121.18
Other Expenses		
53709 Cash Over/Short - NT	10.00	-90.00
54405 Other Expenses - Spartina	4,803.56	522,064.78
54406 Other Expenses - Eelgrass	226,168.05	226,168.05
55418 Other Expenses - T		2,183.00
55419 Other Expenses - NT		4,994.86
Total Other Expenses	230,981.61	755,320.69
Other Professional/Outside Serv		
52109 Outside Services, Other - NT	1,592.17	26,590.92
52118 Outside Services, Other - T		2,460.00
Total Other Professional/Outside Serv	1,592.17	29,050.92
Permits		
51610 Permits - NT		13,867.80
51618 Permits - T		2,811.00
Total Permits		16,678.80
Personnel Expenses		
Contract Temporary Services		
50310 Contract Temporary Services - N	16,850.78	31,435.23
Total Contract Temporary Services	16,850.78	31,435.23
Payroll Burden		
50500 Payroll Benefits, Other - NT	34,372.15	366,246.75
50508 Payroll Benefits, Other - T	8,956.27	94,956.81
6560 Workers' Comp	3,228.23	26,151.56
Total Payroll Burden	46,556.65	487,355.12
Salaries/Wages		
50100 Salaries & Wages - NT	78,806.68	926,330.80
50108 Salaries & Wages - T		0.00
Total Salaries/Wages	78,806.68	926,330.80
Total Personnel Expenses	142,214.11	1,445,121.15

Humboldt Bay Harbor, Recreation & Conservation Dis

Profit and Loss

April 2026

	TOTAL	
	APR 2026	JUL 2025 - APR 2026 (YTD)
Planning Services		
52200 Planning Fees - NT	7,102.65	-7,536.06
52208 Planning Fees - T	2,267.50	27,051.92
Total Planning Services	9,370.15	19,515.86
Rent Expense		
52600 Rent Expense - NT		1,756.00
Total Rent Expense		1,756.00
Small Tools		
52800 Small Tools - NT	344.58	1,964.75
52808 Small Tools - T		121.26
Total Small Tools	344.58	2,086.01
Utilities		
52909 Utilities - NT	26,622.28	230,598.82
52918 Utilities - T	3,713.06	82,677.55
53000 Water, Sewer, & Refuse - NT	16,345.57	116,199.09
53008 Water, Sewer, & Refuse - T	6,414.36	59,153.06
Total Utilities	53,095.27	488,628.52
Total Expenses	\$669,780.88	\$4,640,094.07
NET OPERATING INCOME	\$ -12,367.92	\$4,170,006.14
Other Expenses		
55409 OTHER EXPENSES G/NT	-184,336.98	0.00
Total Other Expenses	\$ -184,336.98	\$0.00
NET OTHER INCOME	\$184,336.98	\$0.00
NET INCOME	\$171,969.06	\$4,170,006.14

Humboldt Bay Harbor, Recreation & Conservation Dis

Bill Payment List

March - April, 2026

DATE	NUM	VENDOR	AMOUNT
10200.1 Cash in PNC, Checking			
03/02/2026	ACH03022026-01	CalPERS Health	-20,632.97
03/13/2026	ACH03132026-01	CalPERS 457 Program	-300.00
03/13/2026	4707	Coastal Business Systems, Inc.	-481.98
03/13/2026	4708	Don's Rent-All	-248.06
03/13/2026	4724	Pierson Building Center	-265.61
03/13/2026	4700	314intermedia	-60.00
03/13/2026	4709	Englund Marine Supply	-320.52
03/13/2026	4730	Solink Corporation	-155.00
03/13/2026	4710	Eureka Oxygen Company	-102.20
03/13/2026	4718	Microbac Laboratories, Inc	-2,085.00
03/13/2026	4703	Bayless Enterprises	-442.65
03/13/2026	4712	Francotyp-Postalia	-146.82
03/13/2026	4715	Humboldt Bay Solar Fund LLC	-6,282.44
03/13/2026	4728	Shelter Cove Resort Improvement District	-133.41
03/13/2026	4714	Humboldt Bay Municipal Water Dist.	-1,424.71
03/13/2026	4729	SHN Consulting Engineers & Geologists	-5,037.10
03/13/2026	4721	Napa Auto Parts	-19.28
03/13/2026	4735	Wiyot Tribe	-2,401.78
03/13/2026	4713	Hum Van	-700.00
03/13/2026	4734	Thrifty Supply	-64.18
03/13/2026	4736	World Oil Environmental Services	-1,832.98
03/13/2026	4716	Humboldt Waste Management Authority	-540.33
03/13/2026	4706	City of Eureka - Wharfinger Building	-225.00
03/13/2026	4717	Mario's Marina, LLC	-1,000.00
03/13/2026	4722	Pacific Gas & Electric (1906-4)	-15,133.69
03/13/2026	4723	Pacific Gas & Electric (8259-4)	-16,264.53
03/13/2026	4702	Amazon Business (Invoices)	-70.78
03/13/2026	4701	Advanced Security Systems	-226.50
03/13/2026	4731	StewTel, Inc.	-349.26
03/13/2026	4733	The Mill Yard	-164.21
03/13/2026	4699	101Netlink	-370.00
03/13/2026	4711	Express Services, Inc.	-5,291.74
03/13/2026	4725	Recology Eel River	-574.79
03/13/2026	4720	Mitchell Law Firm, LLP	-2,182.50
03/13/2026	4726	Recology Humboldt County (061218064)	-402.28
03/13/2026	4732	The League of Women Voters of Humboldt County	-600.00
03/13/2026	4727	Recology Humboldt County (A0060000265)	-2,271.48
03/13/2026	4704	City of Eureka (Sewer)	-3,858.49
03/13/2026	4739	Stoel Rives LLP	-156.00
03/13/2026	4737	Grossman Hague	-8,810.00
03/13/2026	4738	State Water Resources Control Board	-903.31
03/13/2026	4741	Terraphase Engineering Inc	-4,232.34
03/13/2026	4740	Sunbelt Rentals	-2,220.05
03/13/2026	4742	B & B Portable Toilets	-133.69

Humboldt Bay Harbor, Recreation & Conservation Dis

Bill Payment List

March - April, 2026

DATE	NUM	VENDOR	AMOUNT
03/13/2026	4744	Moffatt & Nichol	-40,742.13
03/13/2026	4745	Verizon Wireless	-372.52
03/13/2026	4743	City of Eureka (Water)	-7,512.02
03/13/2026	4747	Pacific Gas & Electric (3494-4)	-378.86
03/13/2026	4746	Broken Tractor LLC	-1,764.26
03/13/2026	4748	Valley Pacific Petroleum Services, Inc	-906.59
03/13/2026	4749	Verizon Wireless	-139.21
03/31/2026	DD	Howser, Suzie	-958.58
03/31/2026	DD	Juchtzer, Rick	-1,498.39
03/27/2026	ACH03272026-01	CalPERS 457 Program	-325.00
03/27/2026	ACH03272026-02	CalPERS Health	-20,632.97
03/27/2026	ACH03272026-03	PERS Unfunded Accrued Liab	-10,916.00
03/27/2026	4765	Dick Taylor Craft Chocolate	-200.00
03/27/2026	4779	World Oil Environmental Services	-195.00
03/27/2026	4763	Coastal Business Systems, Inc.	-481.98
03/27/2026	4768	Humboldt Waste Management Authority	-22.93
03/27/2026	4771	Network Help To Go	-575.00
03/27/2026	4773	Oceantic Network	-2,945.00
03/27/2026	4777	Shelter Cove Fishing Preservation Inc	-3,320.54
03/27/2026	4756	314intermedia	-60.00
03/27/2026	4759	Amazon Business (Invoices)	-368.69
03/27/2026	4769	Microbac Laboratories, Inc	-548.00
03/27/2026	4757	Advanced Security Systems	-220.50
03/27/2026	4767	Gelinas James, Inc.	-1,937.50
03/27/2026	4772	Northern California Safety Consortium	-545.00
03/27/2026	4775	Planwest Partners, Inc.	-11,632.24
03/27/2026	4776	Security Lock & Alarm	-99.23
03/27/2026	4762	CMANC	-2,800.00
03/27/2026	4766	Express Services, Inc.	-5,452.60
03/27/2026	4778	West Coast Hydraulics	-1,078.79
03/27/2026	4774	Offshore Wind California	-2,500.00
03/27/2026	4760	City of Eureka (Sewer)	-4,641.11
03/27/2026	4761	City of Eureka (Water)	-7,534.70
03/27/2026	4781	Don's Rent-All	-330.75
03/27/2026	4782	Western Chainsaw	-489.48
03/13/2026	4719	Mission Uniform & Linen	-958.41
03/27/2026	4784	Mission Uniform & Linen	-840.19
04/10/2026	ACH04102026-01	CalPERS 457 Program	-300.00
04/10/2026	ACH04072026-01	CalPERS 457 Program	-75.00
04/10/2026	4787	Alliant Insurance Services, Inc.	-500.00
04/10/2026	4812	Shelter Cove Fishing Preservation Inc	-2,083.33
04/10/2026	4791	Englund Marine Supply	-369.29
04/10/2026	4814	Solink Corporation	-155.00
04/10/2026	4809	Reincke Marine Fabrication (RMF)	-660.00
04/10/2026	4792	Eureka Oxygen Company	-112.40

Humboldt Bay Harbor, Recreation & Conservation Dis

Bill Payment List

March - April, 2026

DATE	NUM	VENDOR	AMOUNT
04/10/2026	4805	Paul A. Brisso	-8,025.00
04/10/2026	4810	RMI Outdoors	-109.67
04/10/2026	4789	Arcata Recreation	-500.00
04/10/2026	4801	Northern California Gloves	-170.45
04/10/2026	4811	SDRMA	-47.50
04/10/2026	4796	Humboldt Bay Municipal Water Dist.	-1,393.51
04/10/2026	4813	SHN Consulting Engineers & Geologists	-6,418.51
04/10/2026	4800	Napa Auto Parts	-436.87
04/10/2026	4802	Offshore Wind California	-5,000.00
04/10/2026	4815	Standard Insurance Company	-282.20
04/10/2026	4818	Wiyot Tribe	-2,401.78
04/10/2026	4817	Terraphase Engineering Inc	-1,687.05
04/10/2026	4795	Grossman Hague	-5,852.00
04/10/2026	4798	Humboldt Waste Management Authority	-179.18
04/10/2026	4797	Humboldt County Health & Human Services	-1,577.17
04/10/2026	4804	Pacific Gas & Electric (Non-Energy)	-551.36
04/10/2026	4803	Pacific Gas & Electric (1906-4)	-5,395.88
04/10/2026	4788	Amazon Business (Invoices)	-612.22
04/10/2026	4786	Advanced Security Systems	-385.00
04/10/2026	4794	Gelinas James, Inc.	-1,500.00
04/10/2026	4790	B & B Portable Toilets	-133.69
04/10/2026	4816	StewTel, Inc.	-349.26
04/10/2026	4785	101Netlink	-370.00
04/10/2026	4793	Express Services, Inc.	-4,435.73
04/10/2026	4799	Mission Uniform & Linen	-341.30
04/10/2026	4806	Recology Eel River	-574.79
04/10/2026	4807	Recology Humboldt County (061218064)	-402.28
04/10/2026	4808	Recology Humboldt County (A0060000265)	-3,316.34
04/10/2026	4819	Pacific Gas & Electric (8259-4)	-14,966.03
04/10/2026	4820	Cox, Castle & Nicholson LLP	-945.00
04/10/2026	4821	Moffatt & Nichol	-62,664.23
04/24/2026	ACH04242026-01	CalPERS 457 Program	-300.00
04/24/2026	ACH04242026-02	PERS Unfunded Accrued Liab	-10,916.00
04/24/2026	4837	Pacific Gas & Electric (3494-4)	-293.52
04/24/2026	4828	Coastal Business Systems, Inc.	-481.98
04/24/2026	4833	Humboldt Waste Management Authority	-42.36
04/24/2026	4836	Network Help To Go	-575.00
04/24/2026	4838	Pierson Building Center	-11.00
04/24/2026	4823	Alber's Tractor & Ag Work	-250.00
04/24/2026	4831	HCOE - Sequoia Conference Center	-520.00
04/24/2026	4824	Amazon Business (Invoices)	-177.63
04/24/2026	4830	Fortuna Iron	-283.08
04/24/2026	4829	Express Services, Inc.	-3,208.60
04/24/2026	4834	Mission Uniform & Linen	-677.92
04/24/2026	4839	Shelter Cove Resort Improvement District	-151.69

Humboldt Bay Harbor, Recreation & Conservation Dis

Bill Payment List

March - April, 2026

DATE	NUM	VENDOR	AMOUNT
04/24/2026	4835	Mitchell Law Firm, LLP	-1,362.50
04/24/2026	4825	CAPA	-2,606.98
04/24/2026	4832	Humboldt Community Services District	-36.00
04/24/2026	4840	Verizon Wireless	-372.45
04/24/2026	4826	City of Eureka (Sewer)	-5,159.70
04/24/2026	4827	City of Eureka (Water)	-7,407.02
04/24/2026	4841	Planwest Partners, Inc.	-6,927.50
04/24/2026	4842	Samoa Peninsula Fire District	-105.00
04/24/2026	4845	Western Chainsaw	-63.94
04/24/2026	4843	Valley Pacific Petroleum Services, Inc	-945.59
04/24/2026	4844	Verizon Wireless	-163.94
04/24/2026	4847	Wiyot Tribe	-2,401.78
04/24/2026	4846	Redwood Community Action Agency	-77,353.13
04/24/2026	4850	Express Services, Inc.	-3,655.76
04/24/2026	4849	314intermedia	-60.00
04/30/2026	DD	Howser, Suzie	-958.58
04/30/2026	DD	Juchtzer, Rick	-1,498.39
04/29/2026	ACH04292026-01	Francotyp-Postalia	-300.00
04/30/2026	ACH04302026-01	Moffatt & Nichol	-146,602.50
Total for 10200.1 Cash in PNC, Checking			\$ -656,190.39



Humboldt Bay Harbor, Recreation &
Conservation District
PO Box 1030
Eureka, CA 95502

Purchase Order

Date	P.O. No.
5/22/26	2436

Vendor
Boatswains Locker 931 W. 18th Street Costa Mesa, CA 92627-4541 949-642-6800

Ship To
Humboldt Bay Harbor, Recreation and Conservation District PO Box 1030 Eureka, CA 95502

Description	Qty	Rate	Class	Amount
BLI-200 494261, QSC 8.3 Manifold Heat Exchanger Assy	1			\$6,657.21
Tax	1			\$740.79
Freight	1			\$570.00
Approved By:			Total \$7,968.00	

QUOTATION

Boatswains Locker
 931 W. 18th Street
 Costa Mesa, CA 92627-4541
 949-642-6800

Order Number	
1776486	
Order Date	Page
5/15/2026 07:56:53	1 of 1

Bill To:

Humbolt Bay Harbor Rec.& Cons. District
 601 Startare Dr
 Eureka, CA 95501-0765
 US

Ship To:

Humbolt Bay Harbor Rec.& Cons. District
 601 Staretare Dr.
 Eureka, CA 95501

707-443-0801

Requested By: Mr. Robert Provolt

Customer ID: 121000

<i>PO Number</i>	<i>Ship Route</i>	<i>Taker</i>
		GSEARS

<i>Quantities</i>					<i>Item ID</i>	<i>Pricing</i>	<i>Unit</i>	<i>Extended</i>
<i>Ordered</i>	<i>Allocated</i>	<i>Remaining</i>	<i>UOM</i>	<i>Unit Size</i>	<i>Item Description</i>	<i>UOM</i>	<i>Price</i>	<i>Price</i>
					<i>Retail Price</i>	<i>Unit Size</i>		
1.00	0.00	1.00	EA	1.0	BLI-200	EA	6,657.210	6,657.21
					MISC ITEM SPECIAL ORDER	1.0		
					NON-RETURNABLE			
					494261, QSC 8.3 Manifold Heat Exchanger Assy			
					Serial # 773359401			
					0.0000			

Total Lines: 1

SUB-TOTAL: 6,657.21

TAX: 740.79

Total Freight In: 370.00

Total Freight Out: 200.00

TOTAL FREIGHT: 570.00

3% Transaction fee applied to all Credit Card payments. Excluding Online Orders.

AMOUNT DUE: 7,968.00

The Buyer warrants that the parts and equipment purchased from Boatswain's Locker, Inc. are for installation on board marine vessels in navigation only. The Buyer understands that the parts and equipment are necessities under the Commercial Instruments and Maritime Liens Act, 46 U.S. § 31341 and California Harbors and Navigation Code § 491. Failure to pay for goods and services may result in the maritime arrest and attachment of your property in a United States District Court. The Buyer is solely responsible for all cost of arrest, attachment, repossession or suit. Interest will be charged. It is the responsibility of the Buyer/Installer to properly apply and install any parts or equipment, perform service or conduct repairs. Buyer/Installer shall indemnify and hold harmless both Manufacturer and Boatswain's Locker, Inc. for its business practices, quality of work, application, installation and repairs on any and all equipment or components sold or supplied by Boatswain's Locker, Inc. Buyer shall indemnify and hold harmless Boatswain's Locker, Inc. for any failure to follow its recommendations as to suggested service items or replacement of components and Boatswain's Locker, Inc. will not be liable for actual or consequential damages resulting from such failure. Merchandise will be repaired or replaced only on the terms and conditions of the Manufacturer's warranty, if any. Boatswain's Locker® itself makes no warranties with respect to any merchandise, all of which is sold as-is, with all faults. Boatswain's Locker® disclaims all implied warranties, including any warranty of merchantability or fitness for a particular purpose. Boatswain's Locker® guarantee's its service workmanship for a period of ninety days from the date that repairs or services are performed.

RETURN POLICY: Items may be returned for credit within 30 days of the Invoice date, provided the merchandise is in the original packaging and in new and resellable Condition. Defective merchandise will be replaced, repaired or credited subject to the Manufacturer's warranty. Custom order items, kits, cut lengths and electrical items will not be accepted for return. A copy of the original Invoice must accompany any return. Credit will be issued upon receipt and inspection of the item(s) returned. Please wait for the credit to show on your Statement; Do not deduct the cost of the item from your statement. Items being returned from outside our immediate delivery area should be shipped back freight pre-paid and prior authorization is required on all returns. No freight charges will be credited. A 25% re-stocking fee may apply. Special Ordered items are

COMMISSIONERS
 1st Division
 Aaron Newman
 2nd Division
 Greg Dale
 3rd Division
 Stephen Kullmann
 4th Division
 Craig Benson
 5th Division
 Jack Norton

Humboldt Bay
Harbor, Recreation and Conservation District
 (707)443-0801
 P.O. Box 1030
 Eureka, California 95502-1030



STAFF REPORT
HARBOR DISTRICT MEETING
June 11, 2026

TO: Honorable Board President and Harbor District Board Members

FROM: Rob Holmlund, Development Director

DATE: May 18, 2026

TITLE: Receive Status Update Regarding Humboldt Bay Offshore Wind Heavy Lift Marine Terminal Project

STAFF RECOMMENDATION: Receive report and provide direction.

SUMMARY: The Board has requested a monthly update regarding the Humboldt Bay Offshore Wind Heavy Lift Marine Terminal Project. This report will provide an update for June 2026. This month’s update will focus on technical speakers, a review of the status of dredge material testing, and project schedule.

TENTATIVE SCHEDULE FOR TECHNICAL SPEAKERS: The following is a tentative schedule (subject to change) of technical speakers for upcoming Board meetings:

- **June 2026**
 - Phasing Plan and Wharf Design Update
 - Sound and noise modeling - how does it work and what is the scope
- **July 2026**
 - CEQA process
 - Trail, utilities, and solar array update
 - Security perimeters, fencing, gates, and requirements
 - Samoa Lagoons
- **August 2026**
 - Wet storage and foundation generators briefing
 - Solar (ground and buildings)
 - Green Terminal
 - Lighting - Dark Sky Standards
- Electrical load demand
- **September 2026**
 - Buildings and aesthetics
 - Sediment Characterization Results
 - Geotech - what do results mean for design
 - Eelgrass Mitigation program
- **October 2026**
 - Woodley Island Marina Work Dock and Fishermen Storage
 - Humboldt Bay Waterfront Recreation Center
 - Stormwater and grading
 - Ground improvements and seismic
 - Navigation and tow out simulation results

- **November 2026**
 - Beneficial use findings
 - Shoreline stabilization
 - SLR and Hydrodynamic modeling
 - Tsunami Risk
- **December 2026**
 - Onsite and offsite mitigation
 - Cultural resources
 - Anticipated land traffic volumes
 - Supply chain and workforce capacity
- **Additional topics that may be added to the schedule:**
 - Anticipated ship traffic volume
 - estimates and modeling. Add to the 10/8 Tow-out presentation?
- **March or April of 2027 – First hearing of CEQA EIR**
 - Aquaculture related topics
 - Visual Simulations and Aesthetics
 - Schedule update
 - Community/Tribal Engagement Update
 - Permits
 - Community Benefit Program
 - Hydrodynamic model update

COMMISSIONERS

1st Division

Aaron Newman

2nd Division

Greg Dale

3rd Division

Stephen Kullmann

4th Division

Craig Benson

5th Division

Jack Norton

Humboldt Bay
Harbor, Recreation and Conservation District
(707)443-0801
P.O. Box 1030
Eureka, California 95502-1030



STAFF REPORT
HARBOR DISTRICT MEETING
May 14, 2026

TO: Honorable Board President and Harbor District Board Members

FROM: Chris Mikkelsen, Executive Director

DATE: April 28, 2026

TITLE: Consider Adopting Resolution 2026-06, A Resolution Commending Captain John Powell for His Service as a Bar Pilot on Humboldt Bay

STAFF RECOMMENDATION: Staff Recommends that the Board Adopt Resolution 2026-06 and recognize Captain John Powell for his 39 years of service as a Bar Pilot on Humboldt Bay.

SUMMARY: Captain John Powell's remarkable journey from a Deckhand to Chief Bar Pilot is a testament to his dedication, skill, and deep commitment to Humboldt Bay. His illustrious career, impeccable performance record, and passion for mentorship leave a lasting legacy that will safely guide the next generation of mariners.

ATTACHMENTS:

A Resolution 2026-06

***HUMBOLDT BAY HARBOR, RECREATION,
AND CONSERVATION DISTRICT***

RESOLUTION NO. 2026-06

**A RESOLUTION COMMENDING CAPTAIN JOHN POWELL FOR HIS SERVICES AS A BAR PILOT ON
HUMBOLDT BAY**

WHEREAS, Captain John Powell was born and raised in Crescent City, California. He started commercial fishing with his father aboard the Welcome at a very young age. At age 17 he began working for Crowley Maritime assisting the fuel barge into Crescent City. He married his high school sweetheart, Kay, in 1978 and they raised two children together. John and Kay moved to Eureka where John continued to work with Crowley on the Humboldt Tugs. He left to sail on offshore tugs and came back to become the Captain of the famous tug/pilot boat Thor with his mentor and teacher, Captain Art Christensen; and

WHEREAS, Captain Powell came up through the hawse pipe, having started as a deckhand and working his way up to a become a pilot; and

WHEREAS, In 1985 Captain John Powell was recruited by Humboldt Bar Pilots Captain Hoey, Captain Bessielieu and Captain Ohlsson and became the youngest pilot for Humboldt Bar Pilots, being licensed on February 6, 1986; and

WHEREAS, Captain John Powell was fully employed as a Bar Pilot beginning January 1, 1988 and became licensed as a State Bar Pilot through the Humboldt Bay Harbor, Recreation and Conservation District on January 1, 1995; and

WHEREAS, Captain John Powell worked for the Humboldt Bay Harbor, Recreation and Conservation District as a Bar Pilot from October 16, 2006 to August 22, 2014 when he became a Bar Pilot for Humboldt Bay Pilots; and

WHEREAS, In the spring of 2008 Captain John Powell took a leave of absence from the Humboldt Bay Harbor District in order to operate the vessel Koos King for Knutson, as their captain had a medical emergency and there were no other qualified tugboat captains. This act averted potentially significant impact on commercial operations on Humboldt Bay; and

WHEREAS, in July of 2010 Captain John Powell was recognized by Sea Grant California for his time, expertise and vessel support for the Humboldt Bay and Eel River Estuary mapping verification. His involvement contributed to the successful collection of over 130 habitat verifications and resulted in ortho-rectified, digital imagery of Humboldt Bay and the Eel River Estuary that surpassed the quality of previous images; and

WHEREAS, Captain Powell’s dedication to Humboldt Bay was proven as he pushed back his retirement for over three years in order to recruit and train his replacement; and

WHEREAS, Captain John Powell retired in 2025 having served Humboldt Bay the longest and with no “at-fault” incidents; and

WHEREAS, Captain John Powell has left a lasting legacy with numerous positive accomplishments.

NOW, THEREFORE, THE BOARD OF COMMISSIONERS OF THE HUMBOLDT BAY HARBOR, RECREATION, AND CONSERVATION DISTRICT DOES HEREBY RESOLVE AS FOLLOWS: That the Commissioners and staff of the Humboldt Bay Harbor, Recreation and Conservation District do hereby express our heartfelt appreciation for the best efforts and contributions of Captain John Powell as a Bar Pilot and herein wish him the best in all his future endeavors.

PASSED AND ADOPTED by the Humboldt Bay Harbor, Recreation and Conservation District Board of Commissioners at a duly called meeting held on the 11th day of June 2026 by the following polled vote:

AYES:

NOES:

ABSENT:

ABSTAIN:

ATTEST:

**Stephen Kullmann, President
Board of Commissioners**

**Aaron Newman, Secretary
Board of Commissioners**

CERTIFICATE OF SECRETARY

The undersigned, duly qualified and acting Secretary of the HUMBOLDT BAY HARBOR, RECREATION AND CONSERVATION DISTRICT, does hereby certify that the attached Resolution is a true and correct copy of RESOLUTION NO. 2026-06 entitled,

A RESOLUTION COMMENDING CAPTAIN JOHN POWELL FOR HIS SERVICES AS A BAR PILOT ON HUMBOLDT BAY

as regularly adopted at a legally convened meeting of the Board of Commissioners of the HUMBOLDT BAY HARBOR, RECREATION AND CONSERVATION DISTRICT, duly held on the 11th day of June 2026; and further, that such Resolution has been fully recorded in the Journal of Proceedings in my office, and is in full force and effect.

IN WITNESS WHEREOF, I have hereunto set my hand this 11th day of June 2026.

**Aaron Newman, Secretary
Board of Commissioners**

COMMISSIONERS

1st Division

Aaron Newman

2nd Division

Greg Dale

3rd Division

Stephen Kullmann

4th Division

Craig Benson

5th Division

Jack Norton

Humboldt Bay
Harbor, Recreation and Conservation District
(707)443-0801
P.O. Box 1030
Eureka, California 95502-1030



STAFF REPORT
HARBOR DISTRICT MEETING
May 14, 2026

TO: Honorable Board President and Harbor District Board Members

FROM: Chris Mikkelsen, Executive Director

DATE: April 28, 2026

TITLE: Consider Adopting Resolution 2026-07, A Resolution Authorizing Adoption of the Humboldt County Operational Area Hazard Mitigation Plan 2025 Update

STAFF RECOMMENDATION: Staff recommends that the Board: Approve Resolution 2026-07 to adopt the Humboldt County Operational Area Hazard Mitigation Plan 2025 Update.

SUMMARY: The Harbor District partners with the County of Humboldt, Cities, Towns, Tribes, and other Special Districts to pool resources and create consistent mitigation strategies within the Humboldt County Operational Area. Adoption of the Humboldt County Operational Area Hazard Mitigation Plan 2025 Update affirms the Harbor District’s commitment to this effort and makes the Harbor District eligible for future hazard mitigation funding opportunities.

ATTACHMENTS:

- A. Resolution 2026-07**
- B. Humboldt Bay Harbor District Hazard Mitigation Annex**

**HUMBOLDT BAY HARBOR, RECREATION,
AND CONSERVATION DISTRICT**

RESOLUTION NO. 2026-07

**A RESOLUTION AUTHORIZING ADOPTION OF THE HUMBOLDT COUNTY OPERATIONAL AREA
HAZARD MITIGATION PLAN 2025 UPDATE**

WHEREAS, all of Humboldt County has exposure to natural hazards that increase the risk to life, property, environment and the County's economy; and

WHEREAS, pro-active mitigation of known hazards before a disaster event can reduce or eliminate long-term risk to life and property; and

WHEREAS, The Disaster Mitigation Act of 2000 (Public Law 106-390) established new requirements for pre- and post-disaster hazard mitigation programs; and

WHEREAS, a coalition of Humboldt County, Cities, Towns, Tribes and Special Districts with like planning objectives has been formed to pool resources and create consistent mitigation strategies within the Humboldt County Operational Area; and

WHEREAS, the coalition has completed a planning process that engages the public, assesses the risk and vulnerability to the impacts of natural hazards, develops a mitigation strategy consistent with a set of uniform goals and objectives, and creates a plan for implementing, evaluating and revising this strategy;

**NOW, THEREFORE, BE IT RESOLVED THAT THE BOARD OF COMMISSIONERS OF THE
HUMBOLDT BAY HARBOR, RECREATION, AND CONSERVATION DISTRICT:**

1. Adopts in its entirety, the Humboldt County Operational Area Hazard Mitigation Plan (HMP).
2. Will use the adopted and approved portions of the HMP to guide pre- and post-disaster mitigation of the hazards identified.
3. Will coordinate the strategies identified in the HMP with other planning programs and mechanisms under its jurisdictional authority.
4. Will continue its support of the Steering Committee and continue to participate in the Planning Partnership as described by the HMP.
5. Will help to promote and support the mitigation successes of all HMP Planning Partners.

6. Authorizes the Executive Director to coordinate with the County Office of Emergency Services, State Office of Emergency Services and the Federal Emergency Management Agency in the implementation of this Plan.

PASSED AND ADOPTED by the Humboldt Bay Harbor, Recreation and Conservation District Board of Commissioners at a duly called meeting held on the 11th day of June 2026 by the following polled vote:

AYES:

NOES:

ABSENT:

ABSTAIN:

ATTEST:

**Stephen Kullmann, President
Board of Commissioners**

**Aaron Newman, Secretary
Board of Commissioners**

CERTIFICATE OF SECRETARY

The undersigned, duly qualified and acting Secretary of the HUMBOLDT BAY HARBOR, RECREATION AND CONSERVATION DISTRICT, does hereby certify that the attached Resolution is a true and correct copy of RESOLUTION NO. 2026-07 entitled,

**A RESOLUTION AUTHORIZING ADOPTION OF THE HUMBOLDT COUNTY OPERATIONAL AREA
HAZARD MITIGATION PLAN 2025 UPDATE**

as regularly adopted at a legally convened meeting of the Board of Commissioners of the HUMBOLDT BAY HARBOR, RECREATION AND CONSERVATION DISTRICT, duly held on the 11th day of June 2026; and further, that such Resolution has been fully recorded in the Journal of Proceedings in my office, and is in full force and effect.

IN WITNESS WHEREOF, I have hereunto set my hand this 11th day of June 2026.

**Aaron Newman, Secretary
Board of Commissioners**

Humboldt County Operational Area

Hazard Mitigation Plan

VOLUME 2

Planning Partner Annexes

Approved December 2025

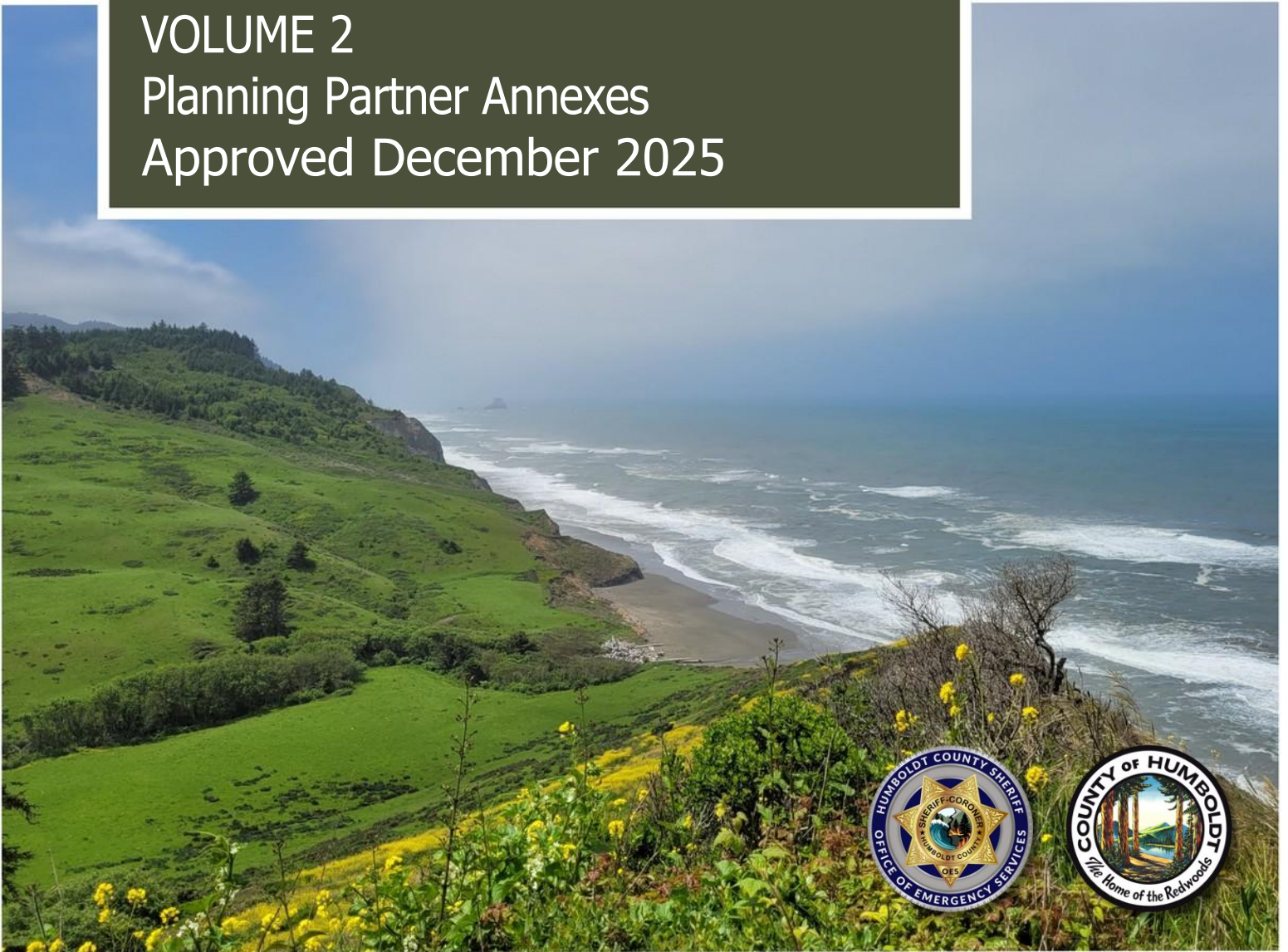

Table of Contents

1. Unincorporated Humboldt County Annex	1
1.1. Planning Process	1
1.2. Risk Assessment.....	5
1.3. Capability Assessment	16
1.4. National Flood Insurance Program.....	35
1.5. Mitigation Strategy	44
2. City of Arcata Annex	58
2.1. Planning Process	58
2.2. Risk Assessment.....	63
2.3. Capability Assessment	75
2.4. National Flood Insurance Program.....	85
2.5. Mitigation Strategy	89
3. Arcata Fire District Annex	108
3.1. Planning Process	108
3.2. Risk Assessment.....	111
3.3. Capability Assessment	118
3.4. National Flood Insurance Program.....	125
3.5. Mitigation Strategy	125
4. Big Lagoon Community Services District Annex	130
4.1. Planning Process	130
4.2. Risk Assessment.....	132
4.3. Capability Assessment	137
4.4. National Flood Insurance Program.....	144
4.5. Mitigation Strategy	144
5. City of Blue Lake Annex	147
5.1. Planning Process	147
5.2. Risk Assessment.....	151

5.3. Capability Assessment	158
5.4. National Flood Insurance Program.....	170
5.5. Mitigation Strategy	174
6. City of Eureka Annex	181
6.1. Planning Process	181
6.2. Risk Assessment.....	185
6.3. Capability Assessment	195
6.4. National Flood Insurance Program.....	202
6.5. Mitigation Strategy	206
7. City of Ferndale Annex	217
7.1. Planning Process	217
7.2. Risk Assessment.....	221
7.3. Capability Assessment	228
7.4. National Flood Insurance Program.....	241
7.5. Mitigation Strategy	246
8. Fieldbrook Glendale Community Services District Annex	261
8.1. Planning Process	261
8.2. Risk Assessment.....	264
8.3. Capability Assessment	271
8.4. National Flood Insurance Program.....	278
8.5. Mitigation Strategy	278
9. City of Fortuna Annex	286
9.1. Planning Process	286
9.2. Risk Assessment.....	290
9.3. Capability Assessment	299
9.4. National Flood Insurance Program.....	309
9.5. Mitigation Strategy	313
10. Fortuna Fire Protection District Annex	322
10.1. Planning Process	322

10.2. Risk Assessment.....	326
10.3. Capability Assessment	332
10.4. National Flood Insurance Program.....	340
10.5. Mitigation Strategy	340
11. Humboldt Bay Fire Joint Powers Authority Annex	344
11.1. Planning Process	344
11.2. Risk Assessment.....	348
11.3. Capability Assessment	356
11.4. National Flood Insurance Program.....	364
11.5. Mitigation Strategy	364
12. Humboldt Bay Harbor, Recreation and Conservation District Annex	369
12.1. Planning Process	369
12.2. Risk Assessment.....	372
12.3. Capability Assessment	377
12.4. National Flood Insurance Program.....	386
12.5. Mitigation Strategy	386
13. Humboldt Bay Municipal Water District Annex	393
13.1. Planning Process	393
13.2. Risk Assessment.....	398
13.3. Capability Assessment	407
13.4. National Flood Insurance Program.....	414
13.5. Mitigation Strategy	414
14. Humboldt Community Services District Annex	424
14.1. Planning Process	424
14.2. Risk Assessment.....	431
14.3. Capability Assessment	437
14.4. National Flood Insurance Program.....	447
14.5. Mitigation Strategy	448

15. Manila Community Services District Annex	454
15.1. Planning Process	454
15.2. Risk Assessment	457
15.3. Capability Assessment	460
15.4. National Flood Insurance Program.....	467
15.5. Mitigation Strategy	468
16. McKinleyville Community Services District Annex	473
16.1. Planning Process	473
16.2. Risk Assessment	478
16.3. Capability Assessment	486
16.4. National Flood Insurance Program.....	493
16.5. Mitigation Strategy	493
17. Peninsula Community Services District and Samoa Peninsula Fire District Annex	499
17.1. Planning Process	499
17.2. Risk Assessment	505
17.3. Capability Assessment	510
17.4. National Flood Insurance Program.....	518
17.5. Mitigation Strategy	519
18. Redway Community Services District Annex	523
18.1. Planning Process	523
18.2. Risk Assessment	526
18.3. Capability Assessment	533
18.4. National Flood Insurance Program.....	541
18.5. Mitigation Strategy	541
19. City of Rio Dell Annex	547
19.1. Planning Process	547
19.2. Risk Assessment	551
19.3. Capability Assessment	558
19.4. National Flood Insurance Program.....	565

19.5. Mitigation Strategy	568
20. Rio Dell Fire Protection District Annex	577
20.1. Planning Process	577
20.2. Risk Assessment	581
20.3. Capability Assessment	588
20.4. National Flood Insurance Program.....	594
20.5. Mitigation Strategy	594
21. Shelter Cove Resort Improvement District No. 1 Annex	598
21.1. Planning Process	598
21.2. Risk Assessment.....	602
21.3. Capability Assessment	609
21.4. National Flood Insurance Program.....	618
21.5. Mitigation Strategy	618
22. Southern Humboldt Community Healthcare District Annex	626
22.1. Planning Process	626
22.2. Risk Assessment.....	630
22.3. Capability Assessment	634
22.4. National Flood Insurance Program.....	641
22.5. Mitigation Strategy	642
23. City of Trinidad Annex	646
23.1. Planning Process	646
23.2. Risk Assessment.....	649
23.3. Capability Assessment	658
23.4. National Flood Insurance Program.....	665
23.5. Mitigation Strategy	666
24. Westhaven Community Services District Annex	675
24.1. Planning Process	675
24.2. Risk Assessment.....	679
24.3. Capability Assessment	685

24.4. National Flood Insurance Program.....	692
24.5. Mitigation Strategy	692
25. Willow Creek Community Services District Annex	699
<hr/>	
25.1. Planning Process	699
25.2. Risk Assessment	703
25.3. Capability Assessment	710
25.4. National Flood Insurance Program.....	717
25.5. Mitigation Strategy	717
26. Willow Creek Fire Protection District Annex	722
<hr/>	
26.1. Planning Process	722
26.2. Risk Assessment	727
26.3. Capability Assessment	734
26.4. National Flood Insurance Program.....	741
26.5. Mitigation Strategy	741

12. Humboldt Bay Harbor, Recreation and Conservation District Annex

This section presents the jurisdictional annex for the Humboldt Bay Harbor, Recreation and Conservation District. The jurisdiction’s governing body passed a formal resolution to participate in this multi-jurisdictional hazard mitigation plan update. Planning priorities for the Humboldt Bay Harbor, Recreation and Conservation District have changed since the last plan update. The district has experienced multiple hazards that highlight the need for resilience that is specifically related to Shelter Cove Boat Launch and a Marine Outfall Line. This was due to severe weather events in 2022 and 2024 when winter storms caused extreme surf and wave action. Shelter Cove is an active FEMA project that has been partially approved, and the marine outfall line has been secured with a 5-year temporary option while a permanent solution is explored. These priorities are reflected in the mitigation actions identified in this annex.

12.1. Planning Process

12.1.1. Contact Information

A key part of hazard mitigation planning is engaging the whole community. This plan was developed by planning consultant IEM, with input from the participating jurisdictions, including the Humboldt Bay Harbor, Recreation and Conservation District, the stakeholders and the public. The Humboldt Bay Harbor, Recreation and Conservation District was represented during the planning process by the following individuals listed in Table 213.

Table 213: Humboldt Bay Harbor, Recreation and Conservation District Points of Contact

Name	Job Title	Jurisdiction/Agency	Preferred Contact Info (Email and/or Phone)
Chris Mikkelsen	Executive Director	Humboldt Bay Harbor, Recreation and Conservation District	cmikkelsen@humboldtбай.org
Bryan Robinson	Facilities Coordinator	Humboldt Bay Harbor, Recreation and Conservation District	brobinson@humboldtбай.org

12.1.2. Stakeholder Engagement

Stakeholders, including local and regional agencies, neighboring communities, representatives of businesses and academia, private organizations, nonprofit organizations and community-based organizations that work directly with and/or provide support to underserved communities and vulnerable populations, were invited to be involved in the planning process and are recognized in Table 214. Stakeholders were invited to the stakeholder meetings through emails, calendar invites and phone calls. Additionally, they were encouraged to complete and share a public survey to gather more information. Lastly, all stakeholders were provided the opportunity to review the draft plan and provide feedback.

Table 214: Stakeholders Invited to Participate

Name	Job Title	Agency or Organization	Preferred Contact Info (Email and/or Phone)	Stakeholder Type
Michiko Mares	General Manager	Humboldt Bay Municipal Water District	gm@hbmwd.com	1. Local and regional agencies involved in hazard mitigation activities
Kelly Allen	Public Works Director	City of Eureka	kallen@eurekaca.gov	2. Agencies that have the authority to regulate development.
Patric Esh	Program Coordinator – Hazard Mitigation Program	Humboldt County OES	pesh2@co.humboldt.ca.us	3. Neighboring communities, including special districts
Sara Dronkers	Chief Executive Officer	Humboldt Area Foundation	SaraD@hafoundation.org	4. Representatives of businesses, academia and other private organizations
Simon Knopf	Disaster Program Manager	American Red Cross	Simon.knopf@redcross.org	5. Representatives of nonprofit organizations, including community-based organizations

12.1.3. Public Outreach

Continued public involvement was imperative to the overall success of the plan's implementation. The update process provided an opportunity to solicit participation from new and existing stakeholders, publicize mitigation success stories and seek additional public comment. The plan's maintenance and update will include continued public and stakeholder involvement and input through attendance at designated committee meetings, web postings, press releases to local media and public hearings. The Humboldt Bay Harbor, Recreation and Conservation District utilized their website to solicit participation in the public survey conducted by Humboldt County.

Public feedback was incorporated into the Humboldt Bay Harbor, Recreation and Conservation District's risk assessment and directly informed the development of updated mitigation actions. Residents provided input through a bilingual survey hosted on the district's website and promoted by Humboldt County. Survey responses and stakeholder engagement efforts indicated strong concern about the vulnerability of coastal infrastructure. These concerns were discussed during stakeholder meetings and reviewed during the Mitigation Action Workshop. The updated mitigation strategy reflects both the technical analysis of risk and the priorities identified through public engagement. These actions demonstrate a comprehensive approach that integrates technical risk analysis with community driven priorities to strengthen local resilience.

12.1.3.1. VULNERABLE POPULATION OUTREACH

Some district residents may be disproportionately affected by natural hazard events for reasons other than proximity to high-risk areas. Vulnerable and underserved residents in Humboldt Bay Harbor, Recreation and Conservation District might have less access to information and resources to help mitigate risk and increase preparedness for emergencies. To better understand the risks and vulnerabilities that district residents face, this planning update developed a bilingual public survey to identify ways to support, enhance and broaden capacity and resilience at the individual and social network levels.

12.1.4. Plan Integration

12.1.4.1. INTEGRATION INTO LOCAL PLANNING MECHANISMS

This section identifies where such integration is already in place and where there are opportunities for further integration in the future. The successful implementation of this plan will require constant and vigilant review of existing plans and programs for coordination and multi-objective opportunities that promote a safe, sustainable community. Existing planning mechanisms into which this plan has been integrated are listed in Table 215.

Table 215: Previous Plan Integration for the Humboldt Bay Harbor, Recreation and Conservation District

Plan Name	Description
None	The previous plan was not integrated into any planning options as there were no plans updated by the annex during this time.

The plan must also identify the local planning mechanisms where the updated hazard mitigation information and actions may be integrated in the future. The plan must describe each participant’s process for integrating information from the mitigation strategy into their identified planning mechanisms. Table 216 displays how each community will integrate the hazard mitigation plan into other planning mechanisms in the future. The district will continue to explore ways of integrating the current plan into planning mechanisms as funding is extremely limited.

Table 216: Future Types of Plan Integration for the Humboldt Bay Harbor, Recreation and Conservation District

Type of Plan	Integration Method
None	The district will continue to explore ways of integrating the current plan into planning mechanisms as funding is extremely limited.

12.2. Risk Assessment

This plan must develop a comprehensive risk assessment to systematically identify the specific hazards and vulnerabilities of the most concern for each jurisdiction, as displayed in Table 217 and Table 218. For further information about these hazards, including extent, please refer to Volume 1 of this HMP.

Table 217: Humboldt Bay Harbor, Recreation and Conservation District Hazards

Type of Hazard Event	Jurisdiction Impact? (Yes/No)	If Not, What Is the Rationale for Omitting Hazard?
Dam Failure	No	Not in direct line with the regional dam (Ruth).
Drought	Yes	N/A

Type of Hazard Event	Jurisdiction Impact? (Yes/No)	If Not, What Is the Rationale for Omitting Hazard?
Earthquake	Yes	N/A
Extreme Temperatures	No	Not typical of jurisdictional geography. No historical basis.
Flooding	Yes	N/A
Landslide	Yes	N/A
Tsunami	Yes	N/A
Wildfire	Yes	N/A
Wind	Yes	N/A
Winter Weather	No	Not a factor for the jurisdiction.

Table 218: Humboldt Bay Harbor, Recreation and Conservation District Risk Assessment

Type of Hazard Event	Probability of Future Occurrence	People Impact	Property Impact	Economy Impact	Category
Drought	High	High	Low	Low	Medium
Earthquake	High	High	High	High	High
Flooding	Medium	Medium	Medium	Low	Medium
Landslide	Low	Low	Low	Low	Low
Tsunami	Medium	Medium	Medium	Medium	Medium
Wildfire	Medium	High	Low	Low	Medium
Wind	High	Low	Low	Low	Medium

Note: The process used to assign risk rankings is described in Volume 1.

12.2.1. Historical Events and Impacts

The following section lists past occurrences of natural hazards for which specific impacts and damages were recorded in the Humboldt Bay Harbor, Recreation and Conservation District. Other hazard events that broadly affected the entire planning area, including the Humboldt Bay Harbor, Recreation and Conservation District, are listed in the risk assessments in Volume 1.

12.2.1.1. HISTORICAL EVENTS

The National Centers for Environmental Information (NCEI) database does not always capture localized hazard data for fire districts. To address this gap, the Humboldt Bay Harbor, Recreation and Conservation District has documented additional significant events, with their impacts detailed below.

DROUGHT

- No events have occurred for this hazard.

EARTHQUAKE

- **Dec. 5, 2024:** Limited to no impacts.

FLOODING

- No events have occurred for this hazard.

LANDSLIDE

- **Winter, 2022 and 2023:** Significant threat as impacts from tide inundation and landslides.

TSUNAMI

- Dec. 5, 2024: Threat only.

WILDFIRE

- **July 16, 2024:** Wildfire smoke caused air quality issues.

WIND

- **July 19, 2024:** Severe wind caused broken dock lines on several boats.

12.2.2. Jurisdiction-Specific Vulnerabilities and Impacts

Table 219 provides information on a few key vulnerabilities for the jurisdiction.

Table 219: Humboldt Bay Harbor, Recreation and Conservation District Vulnerabilities

Hazard	Vulnerabilities
Drought	<p><i>Vulnerabilities:</i> Prolonged drought conditions can impair fire suppression capabilities and impact water-dependent port operations. Low-income or underserved populations could face reduced access to safe water or public facilities.</p> <p><i>Impacts:</i> Reduced water availability could threaten harbor-based emergency operations and increase the risk of equipment failure due to inadequate cooling or hydration. Emergency water distribution may be required, especially for vessels or dockside facilities. Staff may face health issues related to drought, especially in extreme heat.</p>
Earthquake	<p><i>Vulnerabilities:</i> An earthquake could cause structural damage to docks, bridges, roads and utility infrastructure. Much of the district’s critical infrastructure is highly susceptible to seismic damage due to the region’s proximity to the Cascadia Subduction Zone. The district employees working in the field or in unreinforced structures may be vulnerable to injury or fatality in the event of a major seismic activity.</p> <p><i>Impacts:</i> Earthquakes could collapse or severely damage shoreline infrastructure, displace vessels, disrupt access roads and disable utilities. Vulnerable populations may face isolation or loss of access to emergency services.</p>
Flooding	<p><i>Vulnerabilities:</i> Heavy flooding could cause significant erosion, damage buildings and cause docks to fail. The district’s location along Humboldt Bay makes it highly susceptible to coastal and tidal flooding, particularly in low-lying port facilities. Essential infrastructure such as the Fields Landing Terminal, Samoa Peninsula and Woodley Island Marina are exposed. Populations located in low-lying areas are highly vulnerable.</p> <p><i>Impacts:</i> Flooding can damage or destroy docks, marinas and coastal roads; disable utilities and fuel systems; and displace vessels. Floodwaters may isolate vulnerable populations residing on boats or in shoreline communities and interrupt maritime and emergency operations.</p>

Hazard	Vulnerabilities
Landslide	<p><i>Vulnerabilities:</i> The district infrastructure and resources are vulnerable to tideland disruption, silt and sediment depositions. Slopes near tide-influenced areas may experience instability, especially during heavy rainfall. This can threaten transportation routes, sensitive shoreline infrastructure and vulnerable populations.</p> <p><i>Impacts:</i> Landslides may damage containment structures, transportation corridors and utility lines. Deposits of sediment can obstruct waterways and restrict harbor access, disrupting emergency response and commercial activity. Staff may be directly impacted by landslide hazards, causing injury or loss of life.</p>
Tsunami	<p><i>Vulnerabilities:</i> A tsunami could displace vessels and cause docks to fail, damage buildings, close roads and create flooding in inland areas. Displaced Vessels (Boats). Large portions of the district, including Woodley Island Marina, Fields Landing and Samoa Peninsula, lie in the tsunami inundation zone. Residents, workers and infrastructure in these zones are extremely vulnerable.</p> <p><i>Impacts:</i> A tsunami could cause catastrophic damage to harbor infrastructure, displace vessels and flood low-lying facilities. Communications and power systems may be destroyed, impeding emergency coordination. Vulnerable populations without reliable transportation or awareness of evacuation procedures may be at high risk.</p>
Wildfire	<p><i>Vulnerabilities:</i> Although not highly forested, the Samoa Peninsula and other undeveloped areas in the district are at risk from wildfires and wildfire smoke. Vulnerable populations in nearby mobile home communities or those working outdoors are especially affected.</p> <p><i>Impacts:</i> Wildfire smoke can severely affect air quality, delaying port operations and threatening respiratory health. Fires may impact utility systems and hinder road access which would isolate communities and disrupt emergency response.</p>
Wind	<p><i>Vulnerabilities:</i> High winds can damage docks, break mooring lines, and endanger vessels. Infrastructure along exposed coastlines is particularly at risk. Individuals living on boats or working in marine environments are especially vulnerable.</p> <p><i>Impacts:</i> Windstorms can cause property damage, down power lines, and impair transportation across harbor bridges and piers. Dock failures and vessel collisions may require immediate emergency response, potentially straining resources and injuring staff.</p>

12.2.2.1. DEVELOPMENT CHANGES

Table 220 summarizes development trends in the Humboldt Bay Harbor, Recreation, and Conservation District since the preparation of the previous hazard mitigation plan, as well as expected future development trends.

Table 220: Recent and Expected Future Development Trends

Type of Development	Recent Development	Future Development	Overall Vulnerability (Increased, Decreased, No Change)
Residential	The district has experienced about 0.2% annual residential growth year over year for the past decade.	A 300+ unit subdivision is in the approval stages with the county. The developer expects this to take 20 years to build out.	No change
Commercial	Minimal	Very little	No change
Industrial	None	None planned	No change

12.3. Capability Assessment

Local mitigation capabilities are essential for reducing the impact of hazards on communities. Local authorities can effectively mitigate hazards by leveraging existing authorities, policies, programs and resources. The Humboldt Bay Harbor, Recreation, and Conservation District performed an assessment of its existing capabilities for implementing hazard mitigation actions. The capability assessment is evaluated upon a multifaceted approach including the following:

- Planning and Regulatory Capabilities
- Administrative and Technical Capabilities
- Financial Capabilities
- Education and Outreach Capabilities

12.3.1. Planning and Regulatory Capabilities

Table 221 and Table 222 summarize the Humboldt Bay Harbor, Recreation, and Conservation District’s planning and regulatory capabilities, including plans, policies, codes and ordinances that prevent and reduce the impacts of hazards. The Humboldt Bay Harbor, Recreation and Conservation district is a special district without land use authority or its own building code

enforcement. It relies on Humboldt County (2022 California Building Codes) to establish and enforce planning, zoning and development regulations in its service area.

Table 221: Plans

Plans	Does the Plan Address Hazards? (Y/N)	How Can the Plan Be Used to Implement Mitigation Actions?	When Was It Last Updated? When Will It Next Be Updated?
General Plan	Yes Assembly Plan: Yes	Develop and implement protections for shoreline areas most vulnerable to tsunami and sea level rise impacts.	Last Update: 01/2025 Next Update: 07/2025
Recovery Plan	N/A	N/A	N/A
Capital Improvement Plan	Yes	The CIP is used to plan and budget for capital projects. Most mitigation actions are implemented as capital projects. The district continuously uses the CIP to plan for the implementation of mitigation projects.	Last Update: 06/2024 Next Update: 06/2025
Climate Change Adaptation Plan	N/A	N/A	N/A
Community Wildfire Protection Plan	N/A	N/A	N/A
Economic Development Plan	N/A	N/A	N/A
Land Use Plan	N/A	N/A	N/A
Local Emergency Operations Plan	N/A	N/A	N/A
Stormwater Management Plan	N/A	N/A	N/A
Transportation Plan	N/A	N/A	N/A

Plans	Does the Plan Address Hazards? (Y/N)	How Can the Plan Be Used to Implement Mitigation Actions?	When Was It Last Updated? When Will It Next Be Updated?
Substantial Damage Plan	N/A	N/A	N/A
Debris Management Plan	N/A	N/A	N/A

Table 222: Regulations and Ordinances

Regulation or Ordinance	Does this regulation/ ordinance effectively reduce hazard impacts?	Is it adequately administered and enforced?	When was it last updated? When will it next be updated?
Building Code	Yes	Yes	Last Update: 12/2022 Next Update: 12/2025
Flood Insurance Rate Maps	N/A	N/A	N/A
Floodplain Ordinance	N/A	N/A	N/A
Subdivision Ordinance	N/A	N/A	N/A
Zoning Ordinance	N/A	N/A	N/A
Natural Hazard Specific Ordinance	N/A	N/A	N/A
Acquisition of Land for Open Space and Public Recreation Use	N/A	N/A	N/A
Prohibition of Building in At-Risk Areas	N/A	N/A	N/A

12.3.2. Administrative and Technical Capabilities

Table 223 and Table 224 summarize the Humboldt Bay Harbor, Recreation, and Conservation District’s administrative and technical capabilities, including the staff and their respective skills and the available tools to support mitigation actions.

Table 223: Administrative Capabilities

Administrative Capability	Status (Non-Vacant, Vacant)	Is Staffing Adequate?	Is Staff Trained on Hazards?	Is Coordination Effective?
Chief Building Official	No	N/A	N/A	N/A
Grant Writer	No	N/A	N/A	N/A
Civil Engineer	No	N/A	N/A	N/A
Community Planner	No	N/A	N/A	N/A
Emergency Manager	No	N/A	N/A	N/A
Floodplain Administrator	No	N/A	N/A	N/A
Geographic Information System (GIS) Coordinator	No	N/A	N/A	N/A
Planning Commission	No	N/A	N/A	N/A
Fire Safe Council	No	N/A	N/A	N/A
Community Emergency Response Team (CERT)	No	N/A	N/A	N/A
Active Organizations Active in Disaster	No	N/A	N/A	N/A

Table 224: Technical Capabilities

Technical Capability	Utilized? (Y/N)	How Has the Capability Been Used to Assess or Mitigate Risk in the Past?	How Can the Capability Be Used to Assess or Mitigate Risk in the Future?
Hazard Data and Information	Yes	Hazard data regarding unplanned power outages has helped prioritize which sites to install standby generators.	Hazard data regarding flooding and sea level rise is informing the design for a containment berm/wall for a critical lift station. Hazard data regarding fire suppression will be used to determine the size of water storage and water transmission mains to serve a new development.

Technical Capability	Utilized? (Y/N)	How Has the Capability Been Used to Assess or Mitigate Risk in the Past?	How Can the Capability Be Used to Assess or Mitigate Risk in the Future?
GIS	Yes	Reviewing flood maps and identifying critical infrastructure that is vulnerable and identifying elevations and retreat scenarios.	Reviewing fault lines that intersect with district infrastructure and identifying mitigation projects that will reduce vulnerability and risk.
Mutual Aid Agreements	Yes	Mutual aid is used to access operators and equipment during emergencies and recovery efforts.	We work with our partners to identify regional projects that will mitigate hazards and vulnerabilities.
Water and Wastewater Operations	Yes	Hazard data regarding unplanned power outages has helped prioritize which sites to install standby generators.	Hazard data regarding flooding and sea level rise is informing the design for a containment berm/wall for a critical lift station. Hazard data regarding fire suppression will be used to determine the size of water storage and water transmission mains to serve a new development.

12.3.3. Financial Capabilities

Table 225 summarizes the Humboldt Bay Harbor, Recreation, and Conservation District’s financial capabilities, which refer to the resources available to fund mitigation actions. Discussing the funding and financial capabilities of the city is important to determine the kinds of projects that are feasible given their cost.

Table 225: Financial Capabilities

Funding Resource	Utilized? (Y/N)	What Types of Activities?	Can It Be Used to Fund Future Mitigation Actions?	Can It Be Used as a Local Match for a Federal Grant?
Capital Improvement Project Funding	Yes	Yes Retrofit of facilities for seismic concerns.	Yes	Yes

Funding Resource	Utilized? (Y/N)	What Types of Activities?	Can It Be Used to Fund Future Mitigation Actions?	Can It Be Used as a Local Match for a Federal Grant?
General Funds	Yes	Yes Retrofit/improvement of facilities for a wide range of reasons.	Yes	Yes
Hazard Mitigation Grant Program (HMGP/404)	No	N/A	N/A	N/A
Building Resilient Infrastructure and Communities (BRIC)	No	N/A	N/A	N/A
Flood Mitigation Assistance (FMA)	No	N/A	N/A	N/A
Community Development Block Grant (CDBG)	No	N/A	N/A	N/A
Natural Resources Conservation Services (NRCS) Programs	No	N/A	N/A	N/A
U.S. Army Corps of Engineers (USACE) Programs	No	N/A	N/A	N/A

Funding Resource	Utilized? (Y/N)	What Types of Activities?	Can It Be Used to Fund Future Mitigation Actions?	Can It Be Used as a Local Match for a Federal Grant?
Property, Sales, Income or Special Purpose Taxes	Yes	Yes Flood hardening. Seismic retrofitting. Standby generators. Monitoring, data logging and fault altering equipment. Seismic isolation valves. Increased water storage for drinking water and fire suppression. Hydrants. Inspection equipment including CCTV (closed-circuit television) for internal pipe inspections. Sea level rise adaptation.	Yes	Yes
Stormwater Utility Fee	Yes	Yes. The general fund is used to fund outreach activities, including the website and PSAs. Also, the general fund is a mitigation action because it is used to build reserves for use in an emergency or unexpected catastrophic failure that requires immediate funding.	Yes	Yes
Fees for Water, Sewer, Gas or Electric Services	No	N/A	N/A	N/A
Impact Fees from New Development and Redevelopment	No	N/A	N/A	N/A
General Obligation or Special Purpose Bonds	No	N/A	N/A	N/A

Funding Resource	Utilized? (Y/N)	What Types of Activities?	Can It Be Used to Fund Future Mitigation Actions?	Can It Be Used as a Local Match for a Federal Grant?
Federal-Funded Programs	No	N/A	N/A	N/A
State-Funded Programs	No	N/A	N/A	N/A
Private Sector or Nonprofit Programs	No	N/A	N/A	N/A

12.3.4. Education and Outreach Capabilities

Table 226 summarizes the Humboldt Bay Harbor, Recreation, and Conservation District’s education and outreach capabilities, which refer to programs and actions that can communicate information about and encourage risk reduction.

Table 226: Education and Outreach

Education and Outreach Capability	Used? (Y/N)	Does It Incorporate Hazard Mitigation?	Notes
Community Newsletter(s)	Yes	Yes	N/A
Hazard Awareness Campaigns (such as Firewise, Storm Ready, Severe Weather Awareness Week, School Programs)	No	N/A	N/A

Education and Outreach Capability	Used? (Y/N)	Does It Incorporate Hazard Mitigation?	Notes
Public Meetings/Events	Yes	Yes	The District Board meets in public session every second Thursday of the month at 6 p.m. at the district conference room. The meetings include transactional business of the district plus public input and comment. Also, staff provides updates and reports on the district’s activities including hazard mitigation work and public education and outreach.
Emergency Management Listserv	Yes	Yes	N/A
Local News	Yes	Yes	N/A
Distributing Hard Copies of Notices (e.g., Public Libraries, Door-to-Door Outreach)	Yes	Yes	N/A
Insurance Disclosures/ Outreach	Yes	Yes	N/A
Organizations that Represent, Advocate for or Interact with Underserved and Vulnerable Communities	Yes	Yes	Local tribes and Samoa community outreach
Social Media	No	N/A	N/A

12.3.5. Opportunities to Expand and/or Improve Capabilities

The capability assessment findings were reviewed to identify opportunities to expand, initiate or integrate capabilities to further hazard mitigation goals and objectives. These opportunities are included in Table 227. Where such opportunities were identified and determined to be feasible, they are included in the action plan.

Table 227: Opportunities to Expand and/or Improve

Capability Type	Opportunity to Expand and/or Improve
Planning and Regulations	None at this time.
Administrative and Technical	None at this time.
Financial	None at this time.
Education and Outreach	None at this time.

12.4. National Flood Insurance Program

The Humboldt Bay Harbor, Recreation, and Conservation District does not participate in the NFIP because, as a special district, it does not have the authority to do so.

12.5. Mitigation Strategy

The Humboldt Bay Harbor, Recreation, and Conservation District has adopted the same goals and prioritization process as Humboldt County, which is in Volume 1. Previous mitigation actions and their statuses are in Table 228, while new mitigation action items and those carried forward from the previous plan are in Table 229.

12.5.1. Previous Mitigation Actions

Table 228: Previous Mitigation Actions

Mitigation Action	Description	Status
HB1	Replace dock float at Woodley Island Marina.	Deferred. No funding.
HB2	Rebuild/retrofit Redwood Marine Terminal Berth 1.	Deferred. Part of the heavy-lift terminal.
HB3	Rebuild dike in preparation for sea level rise.	Deferred. No funding.
HB4	Assess and enhance the Harbor District’s storm and tsunami warning capability by joining NOAA’s “Storm Ready” and “Tsunami Ready” programs.	Completed. Working with NOAA.
HB5	Retrofit breakwater at Woodley Island Marina.	Deferred. No funding.
HB6	Retrofit work dock at Woodley Island Marina.	Deferred. Part of the heavy-lift terminal.

Mitigation Action	Description	Status
HB7	Retrofit breakwater at Shelter Cove.	Deferred. No funding.
HB8	Install floating breakwater on east end of Woodley Island Marina.	Deferred. No funding.
HB9	Develop standard specifications for levee repair/rehabilitation to minimize breaching and overtopping.	Deferred. No funding.
HB10	Develop Dredge Material Management Program to ensure adequate water depths necessary for safe navigation and emergency access.	In progress, along with the Army Corps of Engineers.
HB11	Fields Landing Terminal Berths.	Deferred. No funding.
HB12	Acquire and make available a floating emergency water delivery booster pump for fire protection.	Deferred. No funding.
HB13	Establish backup power sources for vulnerable infrastructure.	Deferred. No funding.
HB14	Establish a comprehensive dredging program to ensure that channels and marinas are maintained at safe depths for boating and shipping.	In progress, along with the Army Corps of Engineers.
HB15	Develop and implement protections for shoreline areas most vulnerable to tsunami and sea level rise impacts.	Deferred. No funding.
HB16	Improve fire suppression infrastructure (water pumps, generators, etc.) on the Humboldt Bay Samoa Peninsula.	Deferred. Part of the heavy lift terminal.



THIS PAGE INTENTIONALLY LEFT BLANK

12.5.2. Updated Mitigation Actions

Table 229: 2025 Mitigation Actions¹⁸

#	Action Description	Priority Score	Lead Agency	Hazards Mitigated	Potential Funding Source(s)	Estimated Cost	Estimated Timeline	New and/or Existing Asset	Vulnerable Population Benefit?	Community Lifelines Benefit?
HB1	Replace dock float at Woodley Island Marina.	Low	HBHD	Sea level rise, tsunami	General fund	High (over \$500,000)	Short-term (1–2 years)	Existing	No	No
HB2	Rebuild/retrofit Redwood Marine Terminal Berth 1.	Medium	HBHD	Sea level rise, tsunami	Heavy lift terminal funds	High (over \$500,000)	Medium-term (3–5 years)	Existing	No	No
HB3	Rebuild dike in preparation for sea level rise.	High	HBHD	Sea level rise, tsunami	General fund, HMGP	Medium (\$100,000-\$500,000)	Medium-term (3–5 years)	Existing	Yes	Yes
HB4	Retrofit breakwater at Woodley Island Marina.	Low	HBHD	Sea level rise, tsunami	General fund, HMGP	Medium (\$100,000-\$500,000)	Short-term (1–2 years)	Existing	No	No
HB5	Retrofit work dock at Woodley Island Marina.	Low	HBHD	Sea level rise, tsunami	General fund, HMGP	Medium (\$100,000-\$500,000)	Short-term (1–2 years)	Existing	No	No
HB6	Retrofit breakwater at Shelter Cove.	Medium	HBHD	Sea level rise, tsunami	General fund, HMGP	High (over \$500,000)	Short-term (1–2 years)	Existing	No	No
HB7	Install floating breakwater on east end of Woodley Island Marina.	Low	HBHD	Sea level rise, tsunami	General fund, HMGP	Medium (\$100,000-\$500,000)	Short-term (1–2 years)	Existing	No	No

¹⁸ HBHD: Humboldt Bay Harbor District, HMGP: Hazard Mitigation Grant Program

#	Action Description	Priority Score	Lead Agency	Hazards Mitigated	Potential Funding Source(s)	Estimated Cost	Estimated Timeline	New and/or Existing Asset	Vulnerable Population Benefit?	Community Lifelines Benefit?
HB8	Develop standard specifications for levee repair/rehabilitation to minimize breaching and overtopping	High	HBHD	Sea level rise, tsunami	General fund, HMGP	Medium (\$100,000-\$500,000)	Medium-term (3–5 years)	Existing	Yes	Yes
HB9	Field Landing Terminal Berths.	Low	HBHD	Sea level rise, tsunami	Heavy lift terminal funds	High (over \$500,000)	Medium-term (3–5 years)	Existing	No	No
HB10	Acquire and make available a floating emergency water delivery booster pump for fire protection.	High	HBHD	Drought, wildfire	General fund	Low(less than \$100,000)	Short-term (1–2 years)	New	No	No
HB11	Establish backup power sources for vulnerable infrastructure.	Medium	HBHD	All hazards	General fund, HMGP	Medium (\$100,000-\$500,000)	Medium-term (3–5 years)	New	No	No
HB12	Develop and implement protections for shoreline areas most vulnerable to tsunami and sea level rise impacts.	High	HBHD	Sea level rise, tsunami	General fund, HMGP	Medium (\$100,000-\$500,000)	Medium-term (3–5 years)	New	No	No
HB13	Improve fire suppression infrastructure (water pumps, generators, etc.) on the Humboldt Bay Samoa Peninsula.	High	HBHD	Drought, wildfire	General fund, HMGP	High (over \$500,000)	Short-term (1–2 years)	Both	No	Water Systems, Safety and Security
HB14	Rebuild/retrofit Redwood Marine Terminal Berth 2.	Medium	HBHD	Sea level rise, tsunami	Heavy lift terminal funds	High (over \$500,000)	Medium-term (3–5 years)	Existing	No	No
HB15	Retrofit the marine outfall line anchoring at the old pulp mill.	Low	HBHD	Dam failure, earthquake, tsunami	General fund, HMGP	High (over \$500,000)	Short-term (1–2 years)	Existing	No	No

#	Action Description	Priority Score	Lead Agency	Hazards Mitigated	Potential Funding Source(s)	Estimated Cost	Estimated Timeline	New and/or Existing Asset	Vulnerable Population Benefit?	Community Lifelines Benefit?
HB16	Adopt all countywide mitigation actions.	High	HBHD	All hazards	HMGP, general fund	\$150,000	Medium-term (3–5 years)	Both	Yes	All

COMMISSIONERS

1st Division: Aaron Newman
2nd Division: Greg Dale
3rd Division: Stephen Kullmann
4th Division: Craig Benson
5th Division: Jack Norton

**Humboldt Bay Harbor,
Recreation and Conservation
District**
(707) 443-0801
P.O. Box 1030
Eureka, California 95502-1030



STAFF REPORT
HARBOR DISTRICT MEETING
June 11, 2026

TO: Honorable Board President and Harbor District Board Members

FROM: Vanessa Blodgett, District Planner

DATE: June 4, 2026

TITLE: Consider Approving Resolution 2026-08 Adopting an Initial Study/ Mitigated Negative Declaration, a Mitigation Monitoring and Reporting Program, and Establishing Findings Relative to and Approving Harbor District Permit 2023-04 with Conditions for the Humboldt Bay Oyster Company Shellfish Farm

STAFF RECOMMENDATION: Staff recommends that the Board receive a staff report, receive public comment, and adopt Harbor District Resolution No. 2026-08 which includes:

- Establishing Findings Relative to and Adopting an Initial Study/ Mitigated Negative Declaration and Mitigation Monitoring and Reporting Program for the Humboldt Bay Oyster Company Shellfish Farm
- Approving Harbor District Permit 2023-04 with conditions for the Humboldt Bay Oyster Company Shellfish Farm

SUMMARY: Humboldt Bay Oyster Company (HBOC) currently farms Pacific oysters (*Crassostrea gigas*) and Kumamoto oysters (*Magallana sikimeia*) to maturity as well as Manila clams (*Venerupis philippinarum*) for seed in Humboldt Bay, California. The farm was established in 1978 and HBOC purchased it from Kuiper Mariculture in 2002. The proposed project seeks approval for (1) its existing FLUPSY at Woodley Island Marina, raft culture in Mad River Slough, and rack and bag culture methods within existing 17.8 acre farming area in north Humboldt Bay, (2) farming within two proposed expansion areas (up to three (3) acres of culture within 13.9 acres total), and (3) the use of an additional intertidal culture method known as “Longline Culture” at existing and proposed expansion sites.

DISCUSSION:

Humboldt Bay Oyster Co. submitted a permit application to the Humboldt Bay Harbor, Recreation and Conservation District (District) for existing and proposed operations in Humboldt Bay. For California Environmental Quality Act (CEQA) documentation, an Initial Study / Mitigated Negative

Declaration (IS/MND) has been prepared. The Harbor District Board of Commissioners will consider adopting the CEQA document and approving the Harbor District permit for the proposed project. The applicant is also pursuing permits from other regulatory agencies. Following is a description of the proposed project and key considerations.

Project Description

The proposed Project involves approval for the existing FLUPSY, raft culture, and rack and bag culture methods in existing culture areas as well as expand existing rack & bag culture and/or longline culture methods within two proposed expansion areas. The Project would culture Pacific oysters (*Crassostrea gigas*), Kumamoto oysters (*Magallana sikimeia*), and Manila clams (*Venerupis philippinarum*). Manila clams will only be cultured as seed and not grown to adult/market size.

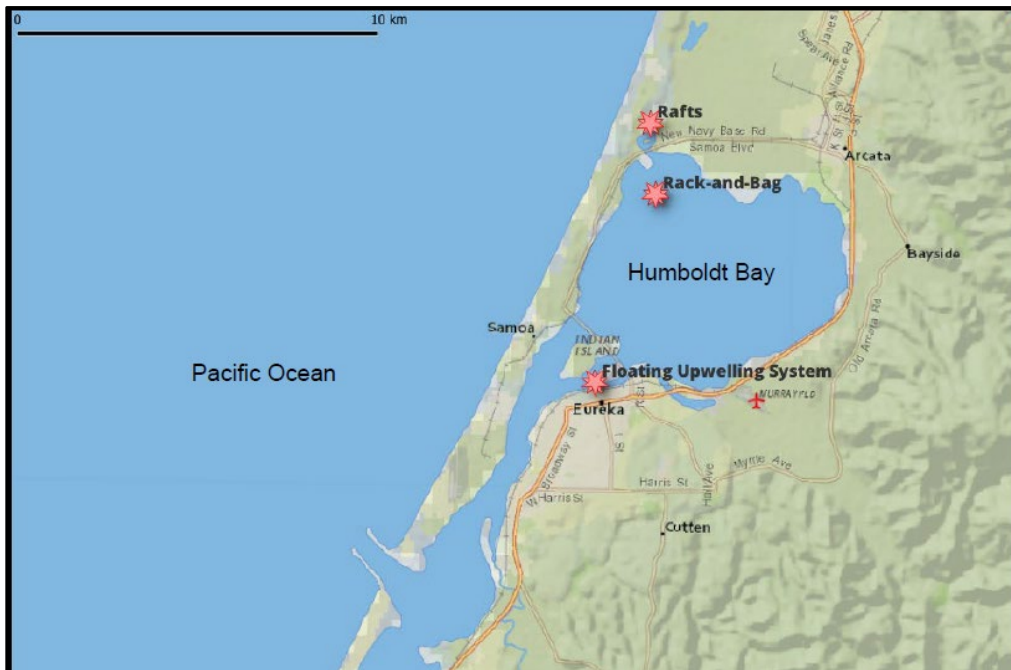

Figure 1. Location of Humboldt Bay Oyster Company's existing culture rafts, bag culture, and FLUPSY.

The FLUPSY is located at Woodley Island Marina, the raft nursery is in Mad River Slough, the existing rack and bag and proposed oyster culture expansion areas are in north Humboldt Bay. HBOC is seeking approval for the existing rack & bag culture method and/or the longline culture method within the Existing Rack and Bag Culture area (17.8 acres) and proposed Expansion Area 1 (3.1 acres) and Expansion Area 2 (10.8 acres). The total footprint of shellfish culture within the two expansion areas will not exceed three acres (i.e., 10.9 acres of the expansion areas will not be cultured). A detailed discussion about each of these areas and methods is in the application materials and IS/MND project description.

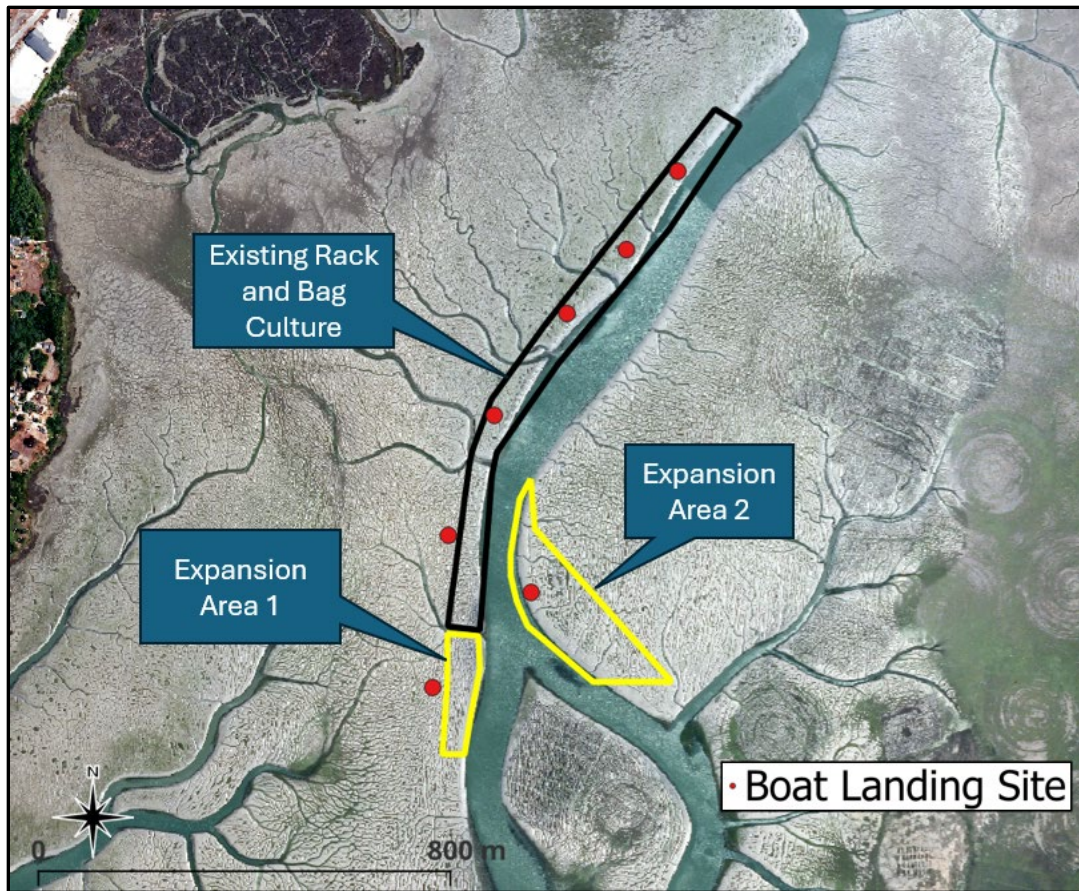

Figure 2. Existing and proposed expansion areas of rack & bag culture and boat landing sites. Longline culture is also proposed as a potential method within these areas.

Mitigation measures and best management practices (BMPs) that are part of the project are summarized in Table 1 and discussed in more detail in the IS/MND individual resource category sections where applicable.

Table 1. Proposed Mitigation Measures and Best Management Practices.

#	Topic	Mitigation Measure / BMP
<p>Mitigation Measure – 1 (BIO)</p>	<p>Biological Resources: Eelgrass Protection</p>	<p>To minimize and avoid impacts to eelgrass beds the following measures will be followed:</p> <ul style="list-style-type: none"> • Vessel routes will avoid eelgrass beds by using channels or vessel transit will occur at higher tides (with a minimum of two feet of water over eelgrass) to avoid loss or damage of eelgrass vegetation due to propeller contact. • Anchoring will not occur in areas with eelgrass. • Prior to placing or installing shellfish cultivation equipment, eelgrass surveys will be conducted within the most recent eelgrass growing season (May through September) using the methods described in the National Marine Fisheries Service’s October 2014 California Eelgrass Mitigation Policy (CEMP). No installation or placement of shellfish cultivation equipment will occur on, in, or over the mapped eelgrass habitat as defined by the CEMP. While installation of shellfish cultivation equipment shall be prohibited within eelgrass habitat, if eelgrass currently occurs, moves, or expands into areas with existing cultivation, the areas may continue to be used for shellfish cultivation.

#	Topic	Mitigation Measure / BMP
		<ul style="list-style-type: none"> The areas within which shellfish culture expansion may occur are a total of 13.9 acres. However, within those 13.9 acres, the total expansion of HBOC's shellfish culture footprint shall not exceed three acres.
Mitigation Measure – 2 (CUL)	Cultural Resources	The Project will comply with the Harbor District Protocol agreed upon between the Harbor District and the Blue Lake Rancheria, Bear River Band of Rohnerville Rancheria, and Wiyot Tribes regarding the inadvertent discovery of archaeological resources, cultural resources, or human remains or grave goods (Attachment A). In coordination with the Wiyot Tribe THPO, a qualified cultural resource monitor will be present if ground disturbing activities related to this Project occur in areas that are within 100 ft of a recorded site and/or involve ground disturbance beyond what is currently proposed.
Mitigation Measure – 3 (HYD)	Vessel Maintenance and Fueling	Project personnel will maintain all vessels used in culture activities to limit the likelihood of release of fuels, lubricants, or other potentially toxic materials associated with vessels due to accident, upset, or other unplanned events. Project personnel will use marine grade fuel cans that are refilled on land, and personnel will carry oil spill absorption pads for use in the event of a spill.
Mitigation Measure – 4 (TRANS)	Debris Management	During farming operations, loose equipment/debris will be surveyed for and immediately removed or secured. Additionally, as feasible, culture equipment will be marked with Humboldt Bay Oyster Company's name and phone number to allow for tracking of the source of debris.
BMP 1	Channel buffer	For newly placed aquaculture equipment, a 10-foot buffer will be maintained between aquaculture equipment and subtidal channels.
BMP 2	Pacific Herring avoidance	As part of standard aquaculture operating practices in Humboldt Bay and to avoid disturbance of Pacific herring spawn if present, the following measures will be implemented: <ul style="list-style-type: none"> During the herring spawning season (December through March), all employees supervising work on tidelands shall be trained by a CDFW biologist to identify herring spawn. Trained personnel shall conduct pre-work surveys at each location where planting, harvesting, or maintenance activities are scheduled. If herring eggs are observed on eelgrass, culture materials, or substrates within or immediately adjacent to the work area, the operator shall: (1) postpone planting, harvesting, or disturbance in the affected area until trained personnel or CDFW staff confirm that eggs have hatched and spawn is no longer present (typically 2 weeks, but may be longer due to successive spawns).
BMP 3	New equipment installation	The installation of shellfish culture equipment in previously uncultured areas will occur between May 15 – June 30 to avoid relatively high Humboldt Bay use periods by black brant and other waterfowl.

CALIFORNIA ENVIRONMENTAL QUALITY ACT:

The Harbor District is the California Environmental Quality Act (CEQA) Lead Agency. The project's Draft Initial Study/Mitigated Negative Declaration (IS/MND) was circulated for public comment from February 9, 2026 to March 10, 2026. One comment letter was received from the California Department of Fish and Wildlife (CDFW) and is included as Attachment B to the IS/MND. The letter made recommendations to strengthen avoidance, minimization, and mitigation measures

across key resource areas, including eelgrass protection (enhanced surveys, buffers, vessel controls, and reduced gear density), wildlife safeguards (seasonal restrictions and spacing), species-specific protections (e.g., sturgeon buffers, herring monitoring), and expanded analysis and monitoring for mudflats, water quality, and cumulative impacts. The IS/MND was revised to address CDFW comments. Additionally, minor administrative revisions were made to update dates and revise the numbering of mitigation measures and BMPs. Revisions are shown in strikethrough and underline format in the Revised IS/MND. As documented throughout the IS/MND, the Project would result in less than significant environmental impacts with incorporation of the mitigation measures and BMPs outlined above.

ATTACHMENTS:

- A. Resolution No. 2026-08 Adopting an Initial Study/ Mitigated Negative Declaration, Adopting a Mitigation Monitoring and Reporting Program, and Establishing Findings Relative to and Approving Harbor District Permit 2023-04 with Conditions for the Humboldt Bay Oyster Company Shellfish Farm Project
- B. Permit 2023-04 for the Humboldt Bay Oyster Company Shellfish Farm Project
- C. Humboldt Bay Oyster Shellfish Farm Mitigation Monitoring and Reporting Program (MMRP)

Documents incorporated here by reference are on file with the Harbor district and available online (<https://humboltdbay.org/public-notices-announcements-information>):

- Revised Initial Study and Mitigated Negative Declaration for Humboldt Bay Oyster Company Shellfish Farm Project (May 2026)
- Initial Study and Proposed Mitigated Negative Declaration for Humboldt Bay Oyster Company Shellfish Farm Project (February 2, 2026)
- Notice of Intent to Adopt a Mitigated Negative Declaration and Draft Initial Study for Humboldt Bay Oyster Company Shellfish Farm (February 2, 2026)
- Application – Humboldt Bay Oyster Company Shellfish Farm Project (July 26, 2023)

***HUMBOLDT BAY HARBOR, RECREATION,
AND CONSERVATION DISTRICT***

RESOLUTION NO. 2026-08

**A RESOLUTION ADOPTING AN INITIAL STUDY/ MITIGATED NEGATIVE DECLARATION,
ADOPTING A MITIGATION MONITORING AND REPORTING PROGRAM, AND ESTABLISHING
FINDINGS RELATIVE TO AND APPROVING HARBOR DISTRICT PERMIT 2023-04 WITH
CONDITIONS FOR THE HUMBOLDT BAY OYSTER COMPANY SHELLFISH FARM PROJECT**

WHEREAS, the Board of Commissioners of the Humboldt Bay Harbor, Recreation, and Conservation District is empowered by Appendix II of the Harbors and Navigation Code, and its own ordinances and resolutions, to grant permits, leases, rights, and privileges; and,

WHEREAS, no permits, rights, leases, and privileges may be granted without first having considered certain potential impacts and without first having made findings relative to said impacts; and,

WHEREAS, Todd Van Herpe applied to the Humboldt Bay Harbor, Recreation, and Conservation District for the Humboldt Bay Oyster Company Shellfish Farm Project "Project"; and

WHEREAS, consistent with Humboldt Bay Harbor, Recreation, and Conservation District Ordinances and the Harbors and Navigation Code, an application was filed and accepted by the Board on November 14, 2024 and a Notice of Application was published and sent to adjacent property owners and regulatory agencies; and

WHEREAS, the Project was subject of an Initial Study / Mitigated Negative Declaration (IS/MND) (SCH# 2026020306) prepared for the Humboldt Bay Harbor, Recreation, and Conservation District as the lead agency under CEQA and circulated pursuant to CEQA Guidelines; and

WHEREAS, the California Environmental Quality Act of 1970, as amended (CEQA) requires that in the approval of a project for which a Mitigated Negative Declaration (MND) has been prepared the decision making body shall review said MND and make findings regarding the significant effects on the environment identified in the MND; and

WHEREAS, a notice of intent to adopt a Mitigated Negative Declaration was circulated for a 30-day public comment period commencing on February 9, 2026; and

WHEREAS, at their June 11, 2026 meeting, the Board of Commissioners for the Humboldt Bay Harbor, Recreation and Conservation District heard public comment on the Initial Study/ Mitigated Negative Declaration; and

WHEREAS, on June 11, 2026, the Board of Commissioners for the Humboldt Bay Harbor, Recreation and Conservation District, after due consideration of all evidence and reports offered for review, does find and determine the following:

The Board of Commissioners for the Humboldt Bay Harbor, Recreation and Conservation District has considered the proposed Mitigated Negative Declaration together with any comments received during the public review process, and finds, on the basis of the whole record before it, that:

- (1) There is no substantial evidence the project will have a significant effect on the environment, and
- (2) The mitigated negative declaration reflects the lead agency's independent judgment and analysis; and

WHEREAS, the documents and materials on which this decision is based are on file at the office of the Humboldt Bay Harbor, Recreation and Conservation District at 601 Startare Drive, Eureka, CA.

NOW, THEREFORE, THE BOARD OF COMMISSIONERS OF THE HUMBOLDT BAY HARBOR, RECREATION, AND CONSERVATION DISTRICT DOES HEREBY RESOLVE AS FOLLOWS:

SECTION 1. That the above recitals are true and correct and are incorporated herein by this reference.

SECTION 2. That after careful consideration of maps, facts, exhibits, correspondence, public and agency comments and testimony, and other evidence submitted in this matter, and, in consideration of the findings, the Board of Commissioners for the Humboldt Bay Harbor, Recreation and Conservation District hereby adopts the Initial Study / Mitigated Negative Declaration and adopts the Mitigation Monitoring and Reporting Program for the Humboldt Bay Oyster Company Shellfish Farm Project.

SECTION 3. That the Board of Commissioners of the Humboldt Bay Harbor, Recreation and Conservation District has found the following to be true and adopts the following findings with respect to the proposed activities contemplated in the permit application for the Humboldt Bay Oyster Company Shellfish Farm Project (Permit 2023-04):

- a) The proposed uses are necessary to promote public safety, health, comfort, and convenience;
- b) The proposed uses are required by the public convenience and necessity;
- c) The proposed uses, as conditioned by the adopted Mitigated Negative Declaration is consistent with CEQA and there is no substantial evidence the project will have a significant effect on the environment;
- d) The proposed use is consistent with the Humboldt Bay Management Plan;
- e) The permit, right, or privilege is reasonably required to promote growth, and to meet area demands, and does not adversely affect the environment or ecology of the area to any substantial degree; and

- f) The proposed use will not produce an unreasonable burden on the natural resources and aesthetics of the area, on the public health and safety, and air and water quality in the vicinity of Humboldt Bay, or on the parks, recreation and scenic area, historic sites and buildings, or archeological sites in the area.

SECTION 4. That the Humboldt Bay Harbor, Recreation and Conservation District Board of Commissioners does hereby issue Permit 2023-04 approving the Humboldt Bay Oyster Company Shellfish Farm Project (Exhibit A-1) with conditions.

PASSED AND ADOPTED by the Humboldt Bay Harbor, Recreation and Conservation District Board of Commissioners at a duly called meeting held on the 11th day of June 2026 by the following polled vote:

AYES:

NOES:

ABSENT:

ATTEST:

**Stephen Kullmann, President
Board of Commissioners**

**Aaron Newman, Secretary
Board of Commissioners**

CERTIFICATE OF SECRETARY

The undersigned, duly qualified and acting Secretary of the HUMBOLDT BAY HARBOR, RECREATION AND CONSERVATION DISTRICT, does hereby certify that the attached Resolution is a true and correct copy of RESOLUTION NO. **2026-08** entitled,

**A RESOLUTION ADOPTING AN INITIAL STUDY/ MITIGATED NEGATIVE DECLARATION,
ADOPTING A MITIGATION MONITORING AND REPORTING PROGRAM, AND ESTABLISHING
FINDINGS RELATIVE TO AND APPROVING HARBOR DISTRICT PERMIT 2023-04 WITH
CONDITIONS FOR THE HUMBOLDT BAY OYSTER COMPANY SHELLFISH FARM PROJECT**

as regularly adopted at a legally convened meeting of the Board of Commissioners of the HUMBOLDT BAY HARBOR, RECREATION AND CONSERVATION DISTRICT, duly held on the **11th day of June 2026**; and further, that such Resolution has been fully recorded in the Journal of Proceedings in my office, and is in full force and effect.

IN WITNESS WHEREOF, I have hereunto set my hand this 11th day of June 2026.

**Aaron Newman, Secretary
Board of Commissioners**



COMMISSIONERS

1st Division: Aaron Newman
2nd Division: Greg Dale
3rd Division: Stephen Kullmann
4th Division: Craig Benson
5th Division: Jack Norton

**Humboldt Bay Harbor,
Recreation and Conservation District**
(707)443-0801
P.O. Box 1030
Eureka, California 95502-1030

**HUMBOLDT BAY HARBOR, RECREATION
AND CONSERVATION DISTRICT**

PERMIT

Permit No. 2023-04

**601 Startare Drive
Woodley Island Marina
P.O. Box 1030
Eureka, CA 95502-1030**

Permittee:

Todd Van Herpe
2797 O'Neil Lane, Eureka, CA 95503
toddvanherpe@gmail.com;
707-499-2388

The Board of Commissioners of the **Humboldt Bay Harbor, Recreation and Conservation District** hereinafter referred to as "**District**", having considered the Application herein, number 2023-04, filed by Todd Van Herpe hereinafter referred to as "**Permittee**", and the **Humboldt Bay Harbor, Recreation and Conservation District (HBHRCD)** as the lead agency, pursuant to the California Environmental Quality Act of 1970, as amended, having made a determination adopting the Mitigated Negative Declaration (SCH# 2026020306) and the Board of Commissioners of the **District** having on June 11, 2026, passed Resolution No. 2026-08 establishing findings relative to the Application by **Permittee** for the Humboldt Bay Oyster Company Shellfish Farm Project as provided for in this Permit, the **Permittee** is hereby authorized to perform the work as more particularly described in the Application filed with the **District** and the mitigated negative declaration referred to above.

You are hereby authorized to conduct that activity described in the Permit Application of **Permittee** consisting of:

Culture of Pacific oysters (*Crassostrea gigas*) and Kumamoto oysters (*Magallana sikimea*) to maturity as well as Manila clams (*Venerupis philippinarum*) for seed in Humboldt Bay, California. The project includes (1) existing FLUPSY at Woodley Island Marina, raft culture in Mad River Slough, and rack and bag culture methods within existing 17.8 acre farming area in north Humboldt Bay, (2) farming within two proposed expansion areas (up to 3 acres of culture within 13.9 acres total), and (3) the use of an additional intertidal culture method known as "Longline Culture" at existing and proposed expansion sites. Details are more particularly described in the Application filed by **Permittee**.

SUBJECT TO THE FOLLOWING TERMS AND CONDITIONS:

1. If the **Permittee** materially changes the activity plan and scope, it will be necessary to request a permit revision.
2. That all work authorized by this Permit shall further be subject to the approval of the following public agencies as applicable:
 - A. United States Army Corps of Engineers
 - B. North Coast Regional Water Quality Control Board
 - C. California Department of Fish and Wildlife
 - D. California Coastal Commission

and **Permittee** shall fully comply with all regulations and conditions affecting such work as imposed by the above agencies.

3. That the mitigation measures and best management practices described in the Initial Study / Mitigated Negative Declaration for the Humboldt Bay Oyster Company Shellfish Farm (SCH# 2026020306) are made conditions of this permit by reference.
4. That this Permit, if not previously revoked or specifically extended, shall cease and be null and void and terminate on **June 11, 2036**. Two (2) five-year extensions may be granted at the discretion of the District.
5. Any in-water work requires a Spill Prevention, Control and Countermeasure (SPCC) plan. Spill kits with appropriate contents will be maintained at the project site. Kits shall be equipped with enough material to provide preliminary containment for a volume of material that can reasonably be expected to spill.
6. All debris shall be removed from the site and disposed of only at an authorized disposal site. Placement of any such material within Humboldt Bay or any wetland area is prohibited.
7. If archeological or cultural features or materials are unearthed during any phase of project activity, all work in the immediate vicinity of the find shall halt until the **Permittee** has contacted the Wiyot Tribe's Cultural Department, and the significance of the resource has been evaluated, to the satisfaction of the Wiyot Tribe. Any mitigation measures that may be deemed necessary will be provided to the Wiyot Cultural Director for review and input to ensure they are consistent with the standards for cultural resource mitigation particularly in cooperation with Native American tribal representatives and the California State Native American Heritage Commission. Mitigation measures shall be implemented by a qualified archeologist representing the **Permittee** prior to resumption of construction activities. If human remains are exposed by project related activity, the **Permittee** shall comply with California State

Health and Safety Code, §7050.5, which states that no further disturbance shall occur until the County Coroner has made the necessary findings as to the origin and disposition pursuant to California Public Resources Code, §5097.98.

8. That there shall be no unreasonable interference with navigation by the work herein authorized.
9. That no attempt shall be made by the **Permittee** to interfere or forbid the full and free use by the public of all navigable waters at or adjacent to the work.
10. That the **District**, its Commissioners, or any officer or employee of the **District** shall in no case be liable for any damages or injury of the work herein authorized which may be caused by or result from future operations undertaken by the **District** for the conservation or improvement of navigation, or for other purposes, and no claim or right to compensation shall accrue from any such damage.
11. That neither the **District**, nor its Board of Commissioners, nor any officer of the **District** shall be liable to any extent for any such injury or damage to any person or property or for the death of any person arising out of or connected with the work authorized by this Permit.
12. That the Board of Commissioners of the **District** may revoke this Permit at any time upon a finding by the **District** of a violation by the **Permittee** of any condition of this Permit.
13. That the **Permittee** shall comply with any regulations, condition, or instructions affecting the work hereby authorized if and when issued by the Federal Water Pollution Control Administration and/or the State of California Water Resources Control Agency having jurisdiction to abate or prevent water pollution. Such regulations, conditions, or instruction in effect or prescribed by Federal or State Agencies are hereby made a condition of this Permit.
14. That as a condition to the issuance of this Permit, **Permittee** agrees to indemnify and hold harmless **District** from and against any and all liability, loss, or damage **District** may suffer from claims and demands for attorneys' fees, costs of suit, and costs of administrative records made against **District** by any and all third parties as a result of third party environmental actions against **District** arising out of the subject matter of this Permit, including, but not limited to attorneys' fees, costs of suit, and costs of administrative records pursuant to the California Code of Civil Procedure §1021.5 or any other applicable local, state or federal laws, whether such attorneys' fees, costs of suit, and costs of administrative records are direct or indirect, or incurred in the compromise, attempted compromise, trial appeal or arbitration of claims

for attorneys' fees, costs of suit, and costs of administrative records in connection with the subject matter of this Permit.

15. That this Permit is valid as of June 11, 2026 and is made subject to the **Permittee** approving and agreeing to the conditions above set forth and executing said approval as hereinafter provided.

EXECUTED on this 11th day of June 2026, by authority of the Board of Commissioners of the **Humboldt Bay Harbor, Recreation and Conservation District**.

STEPHEN KULLMANN, Chair
Board of Commissioners
Humboldt Bay Harbor, Recreation and
Conservation District

Todd Van Herpe, **Permittee**, in the above Permit, hereby accepts and agrees to all of the conditions hereinabove set forth. **Permittee** shall indemnify and hold harmless the **District**, its Board of Commissioners, officers and employees from any and all claims of any nature arising from the performance of and work of improvement contained in the Application for injury, death or damage to any person or property.

Todd Van Herpe, **Permittee**, in the above Permit, agrees to indemnify and hold harmless **District**, its Board of Commissioners, officers and employees from and against any and all liability, loss or damage **District** may suffer from claims and demands from attorneys' fees; costs of suit and costs of administrative records made against **District** by any and all third parties as a result of third party environmental actions against **District** arising out of the subject matter of this Permit including, but not limited to, attorneys' fees, costs of suit and costs of administrative records pursuant to the California Code of Civil Procedure §1021.5 or any other applicable local, state or federal laws, whether such attorney's fees, costs of suit and costs of administrative records are direct or indirect, or incurred in the compromise, attempted compromise, trial, appeal or arbitration of claims for attorneys' fees, costs of suit and costs of administrative records in connection with the subject matter of this Permit.

Dated: _____

Todd Van Herpe



Mitigation Monitoring / Reporting Program (MMRP)

HUMBOLDT BAY HARBOR, RECREATION AND CONSERVATION DISTRICT

This Mitigation Monitoring/Reporting Program (MMRP) has been prepared for the project described below in conformance with California Environmental Quality Act (CEQA) Section 21081.6 and CEQA Guidelines Section 15097, which requires adoption of a MMRP for projects in which the lead agency has adopted mitigation to avoid environmental effects. Best management practices (BMPs) are also noted below. While BMPs have been made a part of the project, they do not constitute mitigation measures by definition, as they are not required to reduce potentially significant impacts to less than significant levels (see CEQA Guidelines § 15071(e)).

PROJECT TITLE: Humboldt Bay Oyster Company (HBOC) Shellfish Farm

SCH #: 2026020306

LEAD AGENCY: Humboldt Bay Harbor, Recreation and Conservation District (HBHRCD) 601 Startare Drive, Eureka, CA 95502

LEAD AGENCY CONTACT PERSON: Vanessa Blodgett, contract District Planner; *phone:* (707) 825-8260; *e-mail:* districtplanner@humboldtby.org

APPLICANT: Humboldt Bay Oyster Company, Todd Van Herpe, toddvanherpe@gmail.com.

PROJECT LOCATION: Mad River Slough, Tidelands in Humboldt Bay (Arcata Bay), and Woodley Island Marina.

GENERAL PLAN LAND USE DESIGNATION: County of Humboldt: Agriculture Exclusive / Natural Resources/ Water; City of Eureka: Woodley Island / Coastal

ZONING: County of Humboldt: Agriculture Exclusive / Natural Resources/ Water; City of Eureka: Woodley Island / Coastal

PROJECT DESCRIPTION: Humboldt Bay Oyster Company (HBOC) currently farms Pacific oysters (*Crassostrea gigas*) and Kumamoto oysters (*Magallana sikimeia*) to maturity as well as Manila clams (*Venerupis philippinarum*) for seed in Humboldt Bay, California. The farm was established in 1978 and HBOC purchased it from Kuiper Mariculture in 2002. The proposed project includes (1) existing FLUPSY at Woodley Island Marina, raft culture in Mad River Slough, and rack and bag culture methods within existing 17.8 acre farming area in north Humboldt Bay, (2) farming within two proposed expansion areas (3.1-acre Expansion Area 1 and 10.8-acre Expansion Area 2), and (3) the use of an additional intertidal culture method known as "Longline Culture" at existing and proposed expansion sites. The total footprint of shellfish culture within the two expansion areas will not exceed three acres. Based on the findings of the Initial Study, it has been determined that all environmental impacts were found to be less than significant or result in impacts that could be mitigated to a less than significant level.

INTRODUCTION: The purpose of this MMRP is to ensure that the mitigation measures adopted in connection with project approval are effectively implemented. The MMRP describes the procedures the

project applicant will use to implement the mitigation measures adopted in connection with the approval of the project, and the methods of monitoring and reporting on such actions. A MMRP is necessary only for impacts which would be significant if not mitigated.

ENFORCEMENT: In accordance with CEQA, the primary responsibility for making a determination with respect to potential environmental effects rests with HBHRCD as the lead agency. As such, HBHRCD is identified as the primary enforcement agency for this MMRP.

PROGRAM MODIFICATION: After adoption of this MMRP, minor changes to this MMRP are permitted but can only be made by the project applicant or its successor subject to the approval of the HBHRCD. The Harbor District Planner, after consultation with affected Departments or Agencies, may make minor modifications to this MMRP. If, for any reason, any mitigation measure or BMP specified in this MMRP cannot be implemented due to factors beyond the control of HBHRCD, at a noticed public hearing before the HBHRCD Board of Commissioners substitution of another mitigation measure may be approved. In no case shall deviations from this MMRP be permitted unless this MMRP continues to satisfy the requirements of CEQA Section 21081.6, as determined by HBHRCD.

MMRP IMPLEMENTATION TABLE: To assure that this MMRP is effectively implemented the table on the following pages establishes the framework that HBHRCD and others will use to implement the adopted mitigation measures and the monitoring and/or reporting of such implementation.

Mitigation Measure/ Best Management Practices (BMP's)	Responsibility for Implementation	Timing of Implementation	Responsibility for Confirming Completion
Mitigation Measures			
<p>Mitigation Measure – 1 (BIO): Eelgrass Protection. To minimize and avoid impacts to eelgrass beds the following measures will be followed:</p> <ul style="list-style-type: none"> • Vessel routes will avoid eelgrass beds by using channels or vessel transit will occur at higher tides (with a minimum of two feet of water over eelgrass) to avoid loss or damage of eelgrass vegetation due to propeller contact. • Anchoring will not occur in areas with eelgrass. • Prior to placing or installing shellfish cultivation equipment, eelgrass surveys will be conducted within the most recent eelgrass growing season (May through September) using the methods described in the National Marine Fisheries Service’s October 2014 California Eelgrass Mitigation Policy (CEMP). No installation or placement of shellfish cultivation equipment will occur on, in, or over the mapped eelgrass habitat as defined by the CEMP. While installation of shellfish cultivation equipment shall be prohibited within eelgrass habitat, if eelgrass currently occurs, moves, or expands into areas with existing cultivation, the areas may continue to be used for shellfish cultivation. • The areas within which shellfish culture expansion may occur are a total of 13.9 acres. However, within those 13.9 acres, the total expansion of HBOC’s shellfish culture footprint shall not exceed three acres. 	HBOC	Duration of project	HBHRCD
<p>Mitigation Measure – 2 (CUL): Cultural Resources. The Project will comply with the Harbor District Protocol agreed upon between the Harbor District and the Blue Lake Rancheria, Bear River Band of Rohnerville Rancheria, and Wiyot Tribes regarding the inadvertent discovery of archaeological resources, cultural resources, or human remains or grave goods. In coordination with the Wiyot Tribe THPO, a qualified cultural resource monitor will be present if ground disturbing activities related to this Project occur in areas that are within 100 ft of a recorded site and/or involve ground disturbance beyond what is currently proposed.</p>	HBOC	Duration of project	HBHRCD
<p>Mitigation Measure – 3 (HYD): Vessel Maintenance and Fueling. Project personnel will maintain all vessels used in culture activities to limit the likelihood of release of fuels, lubricants, or other potentially toxic materials associated with vessels due to accident, upset, or other unplanned events. Project personnel will use marine grade fuel cans that are refilled on land, and personnel will carry oil spill absorption pads for use in the event of a spill.</p>	HBOC	Duration of project	HBHRCD

Mitigation Measure/ Best Management Practices (BMP's)	Responsibility for Implementation	Timing of Implementation	Responsibility for Confirming Completion
<p>Mitigation Measure – 4 (TRANS): Debris Management. During farming operations, loose equipment/debris will be surveyed for and immediately removed or secured. Additionally, as feasible, culture equipment will be marked with Humboldt Bay Oyster Company’s name and phone number to allow for tracking of the source of debris.</p>	HBOC	Duration of project	HBHRCD
<p>Best Management Practices</p>			
<p>BMP 1 – Channel buffer. For newly placed aquaculture equipment, a 10-foot buffer will be maintained between aquaculture equipment and subtidal channels.</p>	HBOC	Duration of project until all aquaculture gear is installed	HBHRCD
<p>BMP 2 - Pacific Herring avoidance. As part of standard aquaculture operating practices in Humboldt Bay and to avoid disturbance of Pacific herring spawn if present, the following measures will be implemented:</p> <ul style="list-style-type: none"> • During the herring spawning season (December through March), all employees supervising work on tidelands shall be trained by a CDFW biologist to identify herring spawn. Trained personnel shall conduct pre-work surveys at each location where planting, harvesting, or maintenance activities are scheduled. • If herring eggs are observed on eelgrass, culture materials, or substrates within or immediately adjacent to the work area, the operator shall: (1) postpone planting, harvesting, or disturbance in the affected area until trained personnel or CDFW staff confirm that eggs have hatched and spawn is no longer present (typically 2 weeks, but may be longer due to successive spawns). 	HBOC	Duration of project	HBHRCD
<p>BMP 3 – New equipment installation. The installation of shellfish culture equipment in previously uncultured areas will occur between May 15 – June 30 to avoid relatively high Humboldt Bay use periods by black brant and other waterfowl.</p>	HBOC	Duration of project until all aquaculture gear is installed	HBHRCD

COMMISSIONERS

1st Division

Aaron Newman

2nd Division

Greg Dale

3rd Division

Stephen Kullmann

4th Division

Craig Benson

5th Division

Jack Norton

Humboldt Bay
Harbor, Recreation and Conservation District
(707)443-0801
P.O. Box 1030
Eureka, California 95502-1030



STAFF REPORT – HARBOR DISTRICT MEETING
June 11, 2026

TO: Honorable Board President and Harbor District Board Members

FROM: Chris Mikkelsen, Executive Director

DATE: June 1, 2026

TITLE: **Authorize the Release of an RFP for the Construction and Installation of Certain Components of a Stormwater Pretreatment System to be Installed at the Fields Landing Boat Yard**

STAFF RECOMMENDATION: Staff recommends that the Board authorize the Release of an RFP for the construction and installation of certain components of a Stormwater Pretreatment System to be installed at the Fields Landing Boat Yard.

DISCUSSION: The Fields Landing Boat Yard's regulated stormwater has been in exceedance status of annual volumes resulting from the vessel repair and maintenance activities that occur on site. While additional best management practices and pretreatment systems have been deployed, the actions are not bringing the site into full compliance with the Industrial General Permit, and construction of a pretreatment system is necessary. Due to District financial constraints, this project, which was proposed for the 2025-26 Fiscal Year, will now be performed through a mix of outside services and self-performance by qualified District staff.

Attachments:

- A. Draft Bid Package
- B. Site Construction Drawings
- C. Insurance Requirements

Bid Package

Fields Landing Boat Yard, Stormwater Treatment System

Fields Landing, California

Including:

- Notice to Contractors,
- Proposal and Agreement,
- Supplemental Conditions,
- Notice to Proceed,
- Notice of Award,
- Plans

Bid Opening:

[TIME], [DATE], 2026

Humboldt Bay Harbor, Recreation & Conservation District
 601 Startare Drive
 Eureka, CA 95501

[Optional/Mandatory] Pre-Bid Meeting:

[TIME], [DATE], 2026

Fields Landing Boat Yard
 1 Yard Road, Fields Landing, CA 95537

Approved:

Chris Mikkelsen
 Executive Director



Humboldt Bay Harbor, Recreation and Conservation District
 601 Startare Drive
 Eureka, CA 95501
 June [] , 2026

Fields Landing Boat Yard, Stormwater Treatment System

Index To Bid Proposal and Contract Documents

<u>Section</u>	<u>Page No</u>
NOTICE TO CONTRACTORS	C-3
PROPOSAL REQUIREMENTS AND CONDITIONS	C-6
1. Bid Proposal Forms	C-6
2. Approximate Estimate.....	C-6
3. Examination of Plans, Specifications, Supplemental Conditions and Site of Work.....	C-6
4. Designation of Subcontractors	C-7
5. Rejection of Proposals	C-7
6. Withdrawal of Proposals	C-7
7. Disqualification of Bidders	C-7
8. Competency of Bidders	C-7
9. Materials Guaranty	C-7
10. Addenda	C-7
11. Waste Reduction and Recycling Program	C-8
AWARD AND EXECUTION OF CONTRACT	C-9
1. Award of Contract	C-9
2. Contract Bonds	C-9
3. Execution and Return of the Contract Agreement Package	C-9
4. Failure to Execute Contract Agreement or Provided Acceptable Bonds or Insurance	C-9
5. Insurance	C-10
DESIGNATION OF SUBCONTRACTORS	C-11
MATERIAL RECYCLING INFORMATION FORM	C-12
NONCOLLUSION DECLARATION	C-13
DRUG-FREE WORKPLACE CERTIFICATION.....	C-14
PROPOSAL	C-15
BID SCHEDULE	C-16
CONTRACT AGREEMENT	C-19
CERTIFICATE OF INSURANCE	C-37
COMMERICAL GENERAL LIABILITY INSURANCE	C-38
AUTOMOBILE LIABILITY SPECIAL ENDORSEMENT	C-39
WORKERS COMPENSATION AND EMPLOYERS LIABILITY SPECIAL ENDORSEMENT	C-40
PERFORMANCE BOND	C-41
LABOR AND MATERIAL BOND	C-43
NOTICE OF AWARD.....	C-45
NOTICE TO PROCEED.....	C-46
PLANS	C-47

NOTICE TO CONTRACTORS

Sealed proposals will be received by the Humboldt Bay Harbor, Recreation & Conservation District (DISTRICT), 601 Startare Drive, Eureka, CA 95501, until [TIME] on [DATE] 2026, at which time they will be publicly opened and read, for performing work in accordance with the Plans and Specifications, therefore, as follows:

Fields Landing Boat Yard, Stormwater Treatment System

There will be a pre-bid meeting at the site, on [TIME] on [DATE] 2026 Attendance is [optional/mandatory].

Bids are required for the entire work as described herein.

General Scope of Work: The base bid work consists of, but is not limited to, furnishing all labor, equipment, and materials to complete the work described below.

1. Mobilization- Establish and maintain a physical presence at the project site for the duration of the work, including but not limited to, attendance at periodic project meetings, compliance with applicable project reporting, invoicing, and progress payment processes, mobilization, temporary shelters, temporary office space and utilities for construction management personnel, temporary fencing as required, potholing to locate utility conflicts, preparation of submittals, and demobilization.
2. Erosion Control- Construction and maintenance of the best management practice (BMP) measures described in the erosion site control plan (ESCP), including but not limited to, drainage inlet protection; stockpile covers; fiber rolls; monitoring BMP installations on a regular basis, and before and after precipitation events; removal and disposal of accumulated onsite sediment, such as daily street sweeping and daily dust control; and equipment and waste management.
3. Clearing and Grubbing- Removal and disposal of debris, grass, roots, and other woody material and vegetation within the limits of construction where shown on the Plans; disposal of these materials at an approved disposal site; and related site cleanup.
4. Demolition- Saw-cutting existing AC pavement along existing culvert pipe; removal and disposal of AC pavement; excavation, removal, and disposal of existing trench fill and culvert pipe; salvage existing tide flex valve to owner; all to the lines and grades shown on the Plans.
5. Hydraulic Structures- Furnishment and installation of hydraulic structures including 1,500-gallon storage tank, pump wet well, and sample vault including, but not limited to: excavation, grading, and preparation of subgrade, including reinforcement where required; removal and disposal of spoils; placement, moisture conditioning, compaction, and facilitation of testing of Class 2 aggregate base and excavation backfill; placement and sealing of structures, risers, and access covers; concrete grade ring forming, placement, curing, and finishing; all to the lines and grades shown on the Plans.

6. Piping, Valving, Trenching, Backfill, and Paving- Trench excavation and spoils disposal; loading and hauling, moisture conditioning, placement, grading, compaction, and the facilitation of testing pipe bedding and trench backfill; furnishment, placement, and testing of piping and valves; connection and sealing of piping to structures; furnishment, placement, and compaction of new asphalt concrete; application of binder (tack coat) where required; cleaning and removal of all debris; all to the lines and grades shown on the Plans.
7. Pump Station- Furnishment and installation of submersible pump and electrical including, but not limited to: install pump station vault and hatch cover; submersible pump guide rail system; install submersible pump; install pump floats; install local exterior control panel; connect pump power supply and float control cables to control panel; saw-cutting AC pavement along new electrical conduit alignment; trench excavation and spoils disposal; loading and hauling, moisture conditioning, placement, grading, compaction, and the facilitation of testing conduit bedding and trench backfill; furnishment, placement, and testing of conduit; furnishment, placement, and compaction of new asphalt concrete; application of binder (tack coat) where required; cleaning and removal of all debris; testing of submersible pump; facilitation of inspections as needed; all to the lines and grades shown on the Plans.

Work includes submittal requirements.

The Work of this Contract may include work covered by lump sum and unit prices.

The foregoing quantities are approximate only, being given as a basis for the comparison of bids, and the DISTRICT does not, expressly or by implication, agree that the actual amount of work will correspond therewith, but reserves the right to increase or decrease the amount of any class or portion of the work in accordance with the Contract Documents, or to omit portions of the work, as may be deemed necessary or expedient.

Plans and Contract Documents, including this Notice to Contractors, Proposal Forms for bidding this project and Agreement can be reviewed at the DISTRICT, 601 Startare Drive, Eureka, CA 95501; Telephone No. 707-443-0801.

The aforementioned documents, as stated above, may also be reviewed at the DISTRICT website <humboldtby.org> or at the [Humboldt Builders' Exchange in Northern California].

No bid will be considered unless it is made on the blank Bid Proposal forms included in this volume (page **C-11 through C-17**). Bidders shall remove or copy the Bid Proposal form and submit the completed Bid Proposal forms as part of the bid proposal package.

Each bidder and subcontractor must be licensed as required by law, and each is required to obtain a Business License from the agency having jurisdiction over the area where the work is to be performed, and to submit a copy of the license to the DISTRICT prior to performing any work on the project.

All Contractors shall possess appropriate Contractor's Licenses for their trade at the time the contract is awarded.

Each Bid Proposal, along with any required supporting bid materials shall be submitted in a sealed envelope bearing the title of the work – Fields Landing Boat Yard, Stormwater Treatment System – and the name of the bidder.

The DISTRICT reserves the right to reject any or all bids.

This is a prevailing wage contract.

The minimum wage rate to be paid under this contract shall be the current prevailing wage for each classification as determined by the Director of the California Department of Industrial Relations, pursuant to California Labor Code Part 7, Chapter 1, Article 2, Sections 1770, 1773 and 1773.1.

Copies of the current prevailing wage rates are available on the internet at the following URL:

<http://www.dir.ca.gov/DLSR/PWD/>

Out of State bidders shall note that, in accordance with California Revenue and Taxation Code (RT&C) Section 18662 and the related regulations requiring withholding of income or franchise tax on certain payments made to nonresidents of California for personal services performed in California, the Humboldt Bay Harbor, Recreation and Conservation District is required to withhold and send to the State seven percent (0.07) of all payments exceeding \$1,500. These provisions apply to payments for this project.

Dated: _____

Chris Mikkelsen
Executive Director

PROPOSAL REQUIREMENTS AND CONDITIONS

1. Bid Proposal Forms

All bid proposals shall be made upon the blank Bid Proposal forms included in this volume, which shall be copied or detached and submitted as part of the bid proposal package.

Please note that additional materials may be required to be submitted for a complete bid proposal package. Bidders are directed to read the contract provisions thoroughly to understand any additional funding agency or other project or bid requirements. Proposals submitted on forms other than those included in this volume will be disregarded. All proposals must give the proposed unit prices, both in writing and in figures, and shall contain original signatures in ink by the bidder, with bidder's address. Where required on the bid form, bidders must quote on all items, and they are hereby warned that failure to do so may disqualify the bid. When quotations on all items are not required, bidders shall insert the words "No Bid" in the space provided for any item on which no quotation is made. If the proposal is made by an individual, that individual's name and Post Office address shall be shown; if made by a firm or partnership, the name and Post Office address of each member of the firm or partnership shall be shown; or if made by a corporation, the proposal shall show the name of the State under the laws of which the corporation was chartered and the names, titles, and business addresses of the President, Secretary, and Treasurer.

Bids shall be delivered to the Humboldt Bay Harbor, Recreation and Conservation District (DISTRICT), on or before the day and hour set for the opening of bids in the advertised "Notice to Contractors." The bids shall be submitted in a sealed envelope and shall bear the title of the work and the name of the bidder. It is the sole responsibility of the bidder to see that their bid is received by the proper time. All bids received after the scheduled closing time for receipt of bids shall be returned to the bidder unopened.

2. Approximate Estimate

The quantities given in the proposal and contract forms are approximate only, being given as a basis for any comparison of bids, and the Board of Commissioners does not, expressly or by implication, agree that the actual amount of work will correspond therewith, but reserves the right to increase or decrease the amount of any class or portion of the work in accordance with the Contract Documents, or to omit portions of the work, as may be deemed necessary or expedient.

3. Examination of Plans, Specifications, Site of the Work

The bidder shall carefully examine the site of the work contemplated and the proposal, plans, specifications, and contract forms, therefore. It will be assumed that the bidder has investigated and is satisfied as to the conditions to be encountered regarding character, quality, and quantities of work to be performed and the materials to be furnished and as to the requirements of these Contract Documents, including Plans, Specifications, Contract Agreement and Supplemental Conditions. It is mutually agreed that submission of a proposal shall be considered "prima facie" evidence that the bidder has made such examination.

4. **Designation of Subcontractors**
All subcontractors doing work in excess of one-half of one percent (0.50%) of the total bid amount shall be designated on page **C-11** of the Bid Proposal.
5. **Rejection of Proposals**
Proposals may be rejected if they show any alterations of form, additions not called for, conditional bids, incomplete bids, erasures, or irregularities of any kind. The DISTRICT reserves the right to reject any and/or all proposals.
6. **Withdrawal of Proposals**
Any bid may be withdrawn at any time prior to the hour fixed in the Notice to Contractors for the opening of bids provided that a request in writing, executed by the bidder or his duly authorized representative, for the withdrawal of such bid is filed with the DISTRICT. The withdrawal of a bid will not prejudice the right of the bidder to file a new bid. Whether or not bids are opened exactly at the time fixed in the advertised "Notice to Contractors," a bid will not be received after that time, nor may a bid be withdrawn after the time fixed in such notice.
7. **Disqualification of Bidders**
More than one proposal from an individual, firm, partnership, or corporation, or combination thereof under the same or different names will not be considered. Reasonable grounds for believing that any bidder is interested in more than one proposal for the work contemplated will cause the rejection of all proposals in which such bidder is interested. If there is reason for believing that collusion exists among bidders, none of the participants in such collusion will be considered in future proposals. Proposals in which the prices obviously are unbalanced may be rejected.
8. **Competency of Bidders**
Bidders must be capable of performing the various items of work bid upon. If requested, the lowest bidder shall furnish, prior to the award of the contract, a satisfactory statement of their financial responsibility, technical ability, project references, and experience. The DISTRICT reserves the right to disqualify bidders who do not exhibit proof of competency, or whose performance on past projects has not been satisfactory.
9. **Materials Guaranty**
Before any contract is awarded, the bidder may be required to furnish a complete statement of the origin, composition, and manufacture of any and all materials to be used in the construction of the work, together with samples, which may be subjected to tests provided for in these Specifications, to determine the quality and fitness of said materials for the work.
10. **Addenda**
If any person contemplating submitting a bid for the proposed contract is in doubt as to the true meaning of any part of the Plans and Specifications or other proposed Contract Documents or finds discrepancies in or omissions from the drawings or Specifications, they may submit to the DISTRICT a written request for an interpretation or correction thereof. The person submitting the request shall deliver said request at least ten (10) days prior to the bid opening date. Any interpretation or correction of the proposed documents will be made

only by an Addendum duly issued; and a copy of such Addendum will be mailed or delivered to each person receiving a set of such documents. The Board of Commissioners will not be responsible for any other explanations or interpretations of the proposed documents.

11. Waste Reduction and Recycling Program

The California legislation AB 939 (1989 CA Integrated Waste Management Act) requires all cities and counties in California to divert 50% of their waste streams away from landfills through recycling, reuse, and reduction programs. The DISTRICT strongly recommends that applicable construction/demolition debris be diverted out of landfills whenever possible. To help facilitate the tracking of material diverted out of landfills for this project, a "MATERIAL RECYCLING INFORMATION FORM" is included in this contract on page C-12, which the Bidder shall fill out and submit as part of these bid documents.

AWARD AND EXECUTION OF CONTRACT

1. Award of Contract

The Humboldt Bay Harbor, Recreation and Conservation District (DISTRICT), in accordance with the provisions of Title VI of the Civil Rights Act of 1964 (78 Stat. 252) and the Regulations of the Department of Commerce (15 C.F.R., Part 8), issued pursuant to such Act, hereby notifies all bidders that it will affirmatively ensure that the contract entered into pursuant to this advertisement will be awarded to the lowest responsible bidder without discrimination on the grounds of race, color, or national origin.

The DISTRICT Board of Commissioners, however, reserves the right to reject any or all bids and to waive any informality or irregularity in bids received. The Board of Commissioners also reserves the right to reject the bid of any bidder who has previously failed to perform properly or did not complete on time contracts with the DISTRICT of a nature similar to this project.

Such award, if made, will be made within fifteen (15) days after the opening of the proposals, and a Notice of Award will be sent to the successful bidder. All bids will be compared on the basis of the Engineer's Estimate of the quantities of work to be done.

For Fields Landing Boat Yard, Stormwater Treatment System, the base bid includes items 1-8 as listed on the Bid Schedule (page C-16). The award of the contract, if it is awarded, will be to the bidder that will conduct base bid items for the lowest total cost, and whose proposal complies with all prescribed requirements.

2. Contract Bonds

See "Item 6: Bonds and Surety Qualifications" of the Contract Agreement on page C-19.

3. Execution and Return of Contract Agreement Package

The following documents shall constitute the Contract Agreement Package:

- A. Contract Agreement
- B. Insurance Documentation (on forms acceptable to the DISTRICT)
- C. Performance Bond
- D. Labor and Material Bond

The Contract Agreement shall be executed, and the Contract Agreement Package shall be returned to the DISTRICT within ten (10) days (not including Sundays) after the bidder has received the Notice of Award.

The Contract Agreement will not be executed by the DISTRICT until the required insurance certificates and all endorsements, or other sufficient proof that the Contract insurance provisions have been complied with, are submitted, approved, and filed with the DISTRICT. No proposal shall be considered binding upon the DISTRICT until the execution of the Contract Agreement by the DISTRICT.

4. Failure to Execute Contract Agreement or Provide Acceptable Bonds or Insurance

Failure to execute and submit the Contract Agreement within ten (10) days (not including Sundays) after the successful bidder has received the Notice of Award shall be just cause for the annulment of the award. Failure of the successful bidder to provide acceptable bonds or insurance documents within 14 days (not including Sundays) after the bidder has executed and returned the Contract Agreement Package to the District shall also be just cause for the annulment of the award.

If the successful bidder refuses or fails to execute the Contract Agreement, the Board of Commissioners may award the contract to the second lowest responsible bidder. If the second lowest responsible bidder refuses or fails to execute the Contract Agreement, the Board of Commissioners may award the contract to the third lowest responsible bidder. On the failure or refusal of the second or third lowest responsible bidder to whom any such contract is so awarded to execute the Contract Agreement, the work may then be re-advertised or may be constructed by day labor, as the Board of Commissioners may decide.

5. Insurance

See "Item 8: Insurance" of the Contract Agreement on page C-19.

6. Schedule of Values

- A. Immediately after award of the Contract and prior to approval of initial payment request, the Contractor shall submit a cost breakdown list (Schedule of Values) to the Engineer for all lump-sum bid items. This list shall consist of the major components of work that make up the lump sum bid items and shall be used for determining progress pay estimates. The Contractor shall fill in the amounts for each component, prorating general costs (such as setup, overhead, and profit) in each component. The total of all components of each lump sum bid item shall equal the total of that lump sum bid item. If the amount indicated in the Contractor's Schedule of Values for any item on the list appears unbalanced, the Engineer may request that the Contractor revise the item as deemed necessary by the Engineer, unless the Contractor can substantiate these costs.
- B. Only work items of value to the Owner shall be included in the list. An item for cleanup shall be listed in the breakdown, in the amount of at least one quarter of one percent (0.25%) of the total bid item. If cleanup proceeds as the Project progresses, then partial payments of these amounts will be made accordingly.

(BID PROPOSAL)

MATERIAL RECYCLING INFORMATION FORM

Fields Landing Boat Yard, Stormwater Treatment System

(Note: Recycling information requested and listed on this page is being collected for audit use only. It will not be used in any way related to the award of the project.)

Bid Item No.	Description of item to be replaced	Estimated Tonnage of item to be recycled	Name & address of recycling facility

Date

Address

Telephone Number

Bidder's Name

Authorized Signature

Type of Organization

State Contractors Lic. No & Exp Date

(BID PROPOSAL)

NONCOLLUSION DECLARATION TO BE EXECUTED BY BIDDER
AND SUBMITTED WITH BID

Fields Landing Boat Yard, Stormwater Treatment System

The undersigned declares:

I am the _____ of , _____ the party making the foregoing bid. The bid is not made in the interest of, or on behalf of, an undisclosed person, partnership, company, association, organization, or corporation. The bid is genuine and not collusive or sham. The bidder has not directly or indirectly induced or solicited any other bidder to put in a false or sham bid. The bidder has not directly or indirectly colluded, conspired, connived, or agreed with any bidder or anyone else to put in a sham bid, or to refrain from bidding. The bidder has not in any manner, directly or indirectly, sought by agreement, communication, or conference with anyone to fix the bid price of the bidder or any other bidder, or to fix any overhead, profit, or cost element of the bid price, or of that of any other bidder. All statements contained in the bid are true. The bidder has not, directly or indirectly, submitted his or her bid price or any breakdown thereof, or the contents thereof, or divulged information or data relative thereto, to any corporation, partnership, company, association, organization, bid depository, or to any member or agent thereof, to effectuate a collusive or sham bid, and has not paid, and will not pay, any person or entity for such purpose. Any person executing this declaration on behalf of a bidder that is a corporation, partnership, joint venture, limited liability company, limited liability partnership, or any other entity, hereby represents that he or she has full power to execute, and does execute, this declaration on behalf of the bidder.

I declare under penalty of perjury under the laws of the State of California that the foregoing is true and correct and that this declaration is executed on _____ (DATE),

at _____ (DISTRICT), _____ (STATE).

Bidder' Name

Authorized Signature

Address 1

Telephone Number

Type of Organization

Address 2

State Contractors Lic. No & Exp Date

(Bid Proposal)

Fields Landing Boat Yard, Stormwater Treatment System

Drug-Free Workplace Certification

The Contractor named below hereby certifies compliance with Government Code Section 8355 in matters related to providing a drug-free workplace. The Contractor named below will:

1. Publish a statement notifying employees that unlawful manufacture, distribution, dispensation, possession or use of a controlled substance is prohibited and specifying actions to be taken against employees for violations, as required by Government Code Section 8355(a)
2. Establish a Drug-Free awareness program as required by Government Code Section 8355(a)(2), to inform about all of the following:
 - a. The dangers of drug abuse in the workplace.
 - b. The persons or organizations policy of maintaining a drug-free workplace
 - c. Any available counseling, rehabilitation, and employee assistance programs, and
 - d. Penalties that may be imposed upon employees for drug abuse violations.
3. Provide as required by Government Code Section 8355(a)(3) that every employee who works on the proposed contract or grant:
 - a. Will receive a copy of the company's drug free policy statement, and
 - b. Will agree to abide by the terms of the companies statement as a condition of employment on the contact or grant.

Certification:

I, the official named below, herby swear that I am duly authorized legally to bind the Contractor to the certification described above. I am fully aware that this certification, executed on the date below, is made under penalty of perjury under the laws of the State of California.

Contractor/Bidders Firm Name: _____

Date Executed: _____

Executed in County of: _____

Contractor Signature: _____

Title: _____

Contractor/Bidder's Firm Mailing Address: _____

Contractor/Bidder's Telephone Number: _____

(BID PROPOSAL)

PROPOSAL TO THE BOARD OF COMMISSIONERS
OF THE HUMBOLDT BAY HARBOR, RECREATION & CONSERVATION DISTRICT

FOR

Fields Landing Boat Yard, Stormwater Treatment System

To the Board of Commissioners of the Humboldt Bay Harbor, Recreation and Conservation District:

The undersigned, as Bidder, declares that the only persons or parties interested in this proposal as principals are those named herein; that this proposal is made without collusion with any other person, firm, or corporation; that Bidder has carefully examined the location(s) of the proposed work and the proposed form of the contract and the plans and specifications; and Bidder agrees if this proposal is accepted, that Bidder will contract with the Humboldt Bay Harbor, Recreation and Conservation District, in the form of the contract annexed hereto, to provide all necessary machinery, tools, apparatus, and other means of construction and to do all the work and furnish all the materials specified in the contract in the manner and time prescribed and according to the requirements of the Engineer; that Bidder will provide the bonds as required herein at the time Bidder executes the contract; that Bidder will provide proof of insurance as provided herein; that Bidder will begin the work on the project within TEN (10) CALENDAR DAYS after receiving notice from the District to proceed and diligently prosecute the same to completion before the expiration of [DATE] (unless extension is granted) from the date of commencement of the work; and that as provided for in the Contract Documents, the liquidated damage shall be in the sum of five hundred (\$500.00) per day for each and every calendar day delay in finishing the work beyond the time described herein; and that Bidder will take in full payment therefore the following unit or lump sum prices, as the case may be, to wit:

SEE BID SCHEDULE ON FOLLOWING PAGE

(BID PROPOSAL)

Base Bid Schedule Humboldt Bay Harbor, Recreation, and Conservation District Fields Landing Boat Yard, Stormwater Treatment System					
Item No	Description	Unit	Quantity	Unit Cost	Total Cost
1	Mobilization	LS	1		
2	Erosion Control	LS	1		
3	Clearing and Grubbing	LS	1		
4	Demolition of Existing Storm Drain	LS	1		
5	Hydraulic Structures	LS	1		
6	Piping, Valving, Trenching, Backfilling, and Paving	LS	1		
7	Pump Station	LS	1		
8	Landscape Restoration	LS	1		

TOTAL BASE BID AMOUNT IN NUMBERS:

\$ _____

TOTAL BASE BID AMOUNT IN WORDS:

(BID PROPOSAL)

The Owner intends to award the Contract to the lowest qualified Bidder. The low bidder shall be determined based on the sum of the Base Project Bid.

Bidder acknowledges receipt of the following Addendum:

ADDENDUM NUMBER: _____ DATE: _____

ADDENDUM NUMBER: _____ DATE: _____

ADDENDUM NUMBER: _____ DATE: _____

It is further understood and agreed that:

- A. In case of a discrepancy between words and figures, the words shall prevail, and in case of a discrepancy between unit prices and totals, the unit price shall prevail.
- B. The DISTRICT reserves the right to eliminate any section of this proposal from the contract without claim of the Contractor for profits lost.
- C. No verbal agreement or conversation with any officer, agent, or employee of the DISTRICT, either before or after the execution of the Agreement, shall affect or modify any of the terms or obligations of this proposal.
- D. The DISTRICT will not be responsible for any errors or omissions on the part of the undersigned in making up their bid, nor will the bidder be released on account of errors.
- E. The undersigned bidder is properly licensed in accordance with the State of California Contractors' State License Law providing for the registration of Contractors.
- F. If the proposal is accepted and the undersigned shall fail to contract as aforesaid and to give the two bonds in the sums to be determined as aforesaid, with surety satisfactory to the Board of Commissioners, within EIGHT (8) CALENDAR DAYS (not including Sundays) after the bidder has received the Notice of Award, the District may, at its option, determine that the bidder has abandoned the contract, and thereafter this proposal and the acceptance thereof shall be null and void.
- G. The undersigned bidder certifies that he has confirmed that the proposed form of contract and the Plans are complete.

Date

Bidder's Name

Address

Authorized Signature

Type of Organization

Type of Organization

Telephone Number

State Contractor's Lic. No & Exp Date

THE ABOVE SIGNED ACKNOWLEDGES THAT THESE REPRESENTATIONS ARE MADE UNDER PENALTY OF PERJURY.

Purchase Order# _____

CONTRACT AGREEMENT

HUMBOLDT BAY HARBOR, RECREATION, AND CONSERVATION DISTRICT

Fields Landing Boat Yard, Stormwater Treatment System

This Contract is made and entered into this _____ () day of _____ 2026, by and between the Humboldt Bay Harbor, Recreation, and Conservation District, a California public entity (“DISTRICT”), and _____ as (“CONTRACTOR”).

The parties agree as follows:

1. **Scope of Services:** CONTRACTOR agrees to complete all work as shown on the Plans, attached hereto and incorporated herein (“Work”). All work shall be completed in accordance with the Contract Documents.
2. **Contract Documents Include:** The contract documents include this Contract, all Plans, the Certificates of Insurance, Workers’ Compensation Certificate, and Bonds (if any), and Supplemental Conditions (“Contract Documents”). All of the provisions of the Contract Documents are hereby incorporated in and made a part of this Contract as if fully set forth herein.
3. **Compensation:** The DISTRICT shall pay CONTRACTOR for the price set forth by him/her in the accepted Bid. The total compensation to be paid will be computed on the basis of the quantity of work actually performed in accordance with the Contract Documents and paid for at the stipulated contract unit or lump sum prices, as the case may be. Total compensation shall not exceed the Base Bid total and any amount of Additive Alternate Bid that the DISTRICT awards.
4. **Payment:** CONTRACTOR shall submit monthly invoices for completed tasks as outlined in the submitted Bid Schedule. All invoices must include the Purchase Order Number that will be issued with the award of contract. Invoices received without reference to correct Purchase Order Number will be returned to CONTRACTOR without processing. The DISTRICT agrees to pay invoices within 90 days upon receipt of invoice less 10% until approval and acceptance of completed project. The final invoice will be paid within 90 days from the DISTRICT’s acceptance and approval of completed project. All payments are subject to final audit upon completion of services or other termination of this Contract.
5. **Commencement of Work, Time for Completion:** No work shall be performed or furnished under this Contract until the DISTRICT has delivered a signed Contract and Notice to Proceed to the CONTRACTOR. The CONTRACTOR shall complete the Work by October 31st of the contract year, (the “Completion Date”). An extension to the Completion Date may be allowed in accordance with Section 37, Uncontrollable Circumstances. However, extension would need to be approved by regulatory agencies in addition to the DISTRICT. The CONTRACTOR shall at all times employ such force, plant, materials, and tools as will be sufficient, in the opinion of the DISTRICT Representative, to perform required activities at a pace sufficient to complete the Work by the Completion Date. If in the opinion of the

DISTRICT Representative, the CONTRACTOR has failed or is failing to employ sufficient force, materials, and tools, or, to maintain adequate progress, the DISTRICT Representative may, at no additional cost to the DISTRICT, require the CONTRACTOR to increase progress of work. The CONTRACTOR shall implement action required to increase progress and report the action or actions to be taken to the DISTRICT Representative within two workdays following the DISTRICT Representative's order to increase progress.

6. Bonds and Surety Qualifications: If indicated below, the successful CONTRACTOR shall, within 15 days of contract award and before execution of the contract, furnish a Bond for Faithful Performance and/or a Payment Bond (also called Labor and Materials Bond) on forms provided by the DISTRICT, each in the amount of 100 percent of the contract price. The Bond for Faithful Performance shall remain in effect during the performance of the work, and for 365 days after recordation of a Notice of Completion, or if a Notice of Completion is not recorded by the DISTRICT, within thirty days of completion of the Work. The Payment Bond shall remain in effect until recordation of the Notice of Completion, or if a Notice of Completion is not recorded by the DISTRICT, for 60 days after completion of the Work. All Bonds shall be furnished by the CONTRACTOR at its own cost and expense. All bonds shall be executed by such sureties as are admitted to transact surety insurance in the State of California. Should an objection as to the sufficiency of an admitted surety on a bond be made, California Code of Civil Procedure Section 995.660 shall apply.

Performance Bond Required: Payment Bond Required: [check.only.if.required]

7. Independent Contractor: Parties intend that the successful CONTRACTOR, in performing Work, shall act as an independent contractor and shall have control of his work and the manner in which it is performed. CONTRACTOR shall be free to contract for similar services to be performed for others while under contract with DISTRICT, provided no conflict of interest is created. CONTRACTOR is not to be considered an agent or employee of the DISTRICT.
8. Insurance: All Work shall be performed entirely at the CONTRACTOR's risk. Prior to the beginning of and throughout the duration of the Work, CONTRACTOR shall procure and maintain for the duration of the contract, and for a minimum of five (5) years after completion of all Work, insurance against claims for injuries to persons or damages to property which may arise from or in connection with the performance of the Work hereunder by the CONTRACTOR, his agents, representatives, employees, or subcontractors. All insurance carriers shall be admitted in the state of California and have an A.M. Best's rating of A- or better and minimum financial size VII. Coverage shall be at least as broad as the following minimum limits:
 - a. Commercial.General.Liability: Insurance Services Office (ISO) "Commercial General Liability" policy form CG 00 01 or the exact equivalent on an "occurrence" basis, including products and completed operations, property damage, bodily injury and personal and advertising injury with limits no less than \$2,000,000 per occurrence for all covered losses. If a general aggregate limit applies, either the general aggregate limit shall apply separately to this project/location, or the general aggregate limit shall be

twice the required occurrence limit. Additional insured coverage for the DISTRICT shall not be limited to its vicarious liability. Defense costs must be paid in addition to limits.

- b. Automobile.Insurance: ISO Auto Coverage Form CA 00 01 including symbol 1 (Any Auto) or the exact equivalent. Limits are subject to review, but in no event to be less than \$1,000,000 per accident for bodily injury and property damage. If CONTRACTOR or CONTRACTOR's employees will use personal autos on this project, CONTRACTOR shall provide evidence of personal auto liability coverage for each such person.
- c. Workers.Compensation.Insurance: Covering all employees and volunteers as required by the State of California on a state-approved policy form, and Employer's Liability insurance with a limit of no less than \$1,000,000 per accident for bodily injury or disease.
- d. Excess.or.Umbrella.Liability.Insurance.(Over.Primary): If used to meet limit requirements, shall provide coverage at least as broad as specified for the underlying coverage. Such policy or policies shall include a drop-down provision providing coverage above a maximum \$25,000 self-insured retention for liability not covered by primary but covered by the umbrella. Coverage shall be provided on a "pay on behalf of" basis, with defense costs payable in addition to policy limits. Such insurance shall contain or be endorsed to contain a provision that such coverage shall also apply on a primary and non-contributory basis for the benefit of the DISTRICT before the DISTRICT's insurance or self-insurance shall be called upon to protect it as a named insured. There shall be no cross-liability exclusion precluding coverage for claims or suits by one insured against another. Coverage shall be applicable to DISTRICT for injury to employees of CONTRACTOR, sub-CONTRACTORS or others involved in performing Work under this Contract. The scope of coverage provided is subject to approval of DISTRICT following receipt of proof of insurance as required herein.
- e. General.Conditions.Pertaining.to.Insurance:
 - 1. CONTRACTOR shall have its insurer endorse the third party general liability coverage to include as additional insureds the DISTRICT, its officials, employees, volunteers and agents, using standard ISO endorsement CG 20 10. The additional insured coverage under CONTRACTOR's policy shall be provided on a primary, non-contributing basis in relation to any other insurance or self-insurance available to the DISTRICT. CONTRACTOR's policy shall not seek contribution from the DISTRICT's insurance or self-insurance and shall be at least as broad as ISO form CG 20 01 04 13.
 - 2. It is a requirement under this Contract that any available insurance proceeds broader than or in excess of the specified minimum insurance coverage and/or limits required in this Section 8 shall be available to the DISTRICT as an additional insured. Furthermore, the requirements for coverage and limits shall be (1) the minimum coverage and limits specified in this Contract, or (2) the broader coverage and maximum limits of coverage of any insurance policy or proceeds available to the named insured, whichever is greater.

3. All self-insured retentions (SIR) must be disclosed to the DISTRICT for approval and shall not reduce the limits of liability. Policies containing any SIR shall provide or be endorsed to provide that the SIR may be satisfied by either the named insured or the DISTRICT.
4. The DISTRICT reserves the right to obtain a full certified copy of any insurance policy and any endorsement. Failure to exercise this right shall not constitute a waiver of the DISTRICT's right.
5. Certificates shall contain a statement that the policy will not be cancelled except after thirty (30) days prior written notice to the DISTRICT.
6. CONTRACTOR agrees to waive subrogation rights against the DISTRICT regardless of the applicability of any insurance proceeds, and to require that all subcontractors and sub-subcontractors do likewise.
7. Proof of compliance with these insurance requirements, consisting of certificates of insurance evidencing all required coverages and an additional insured endorsement to CONTRACTOR's general liability policy, shall be delivered to the DISTRICT at or prior to the execution of the Contract.
8. All coverage types and limits required are subject to approval, modification and additional requirements by the DISTRICT, as the need arises. CONTRACTOR shall not make any reductions in scope of coverage (e.g. elimination of contractual liability or reduction of discovery period) that may affect the DISTRICT's protection without the DISTRICT's prior written consent.
9. The DISTRICT reserves the right at any time during the term of the Contract to change the amounts and types of insurance required by giving the CONTRACTOR ninety (90) days advance written notice of such change. If such change results in substantial additional cost to the CONTRACTOR, the DISTRICT will negotiate additional compensation proportional to the increased benefit to the DISTRICT.
10. In the event CONTRACTOR fails to obtain or maintain completed operations coverage as required by this Contract, the DISTRICT at its sole discretion may purchase the coverage required and the cost will be paid by CONTRACTOR.

fj Maritime.

CONTRACTOR shall provide and maintain insurance under the United States Longshore and Harbor Workers' Compensation Act if the work covered by the Contract Agreement includes activities subject to that Act (work whole or in part upon the navigable waters of the United States, including any adjoining pier, wharf, dry dock, terminal, building way, marine railway, or adjoining areas) throughout the duration of the Contract Agreement.

CONTRACTOR shall provide and maintain insurance under the Jones Act in the event that the work covered by the Contract Agreement includes activities covered by the Jones Act

(including, but not limited to, work from ships, vessels, barges, or dredges) throughout the duration of the Contract Agreement. It is understood that the coverage may not specifically be named United States Longshore and Harbor Workers' Compensation Act insurance and/or Jones Act Insurance. In order to insure compliance, CONTRACTOR shall supply documentation from the insurance carrier that the coverage is in compliance with the United States Longshore and Harbor Workers' Compensation Act and Jones Act.

9. Indemnity:

- a. To the fullest extent allowed by law, CONTRACTOR shall indemnify, defend and hold harmless the DISTRICT and its officers, officials, employees, and volunteers through legal counsel reasonably acceptable to the DISTRICT, from and against any and all claims, damages and expenses, including attorney fees and costs of litigation, caused in whole or in part by any negligent act or omission of the CONTRACTOR, any subcontractor, anyone directly or indirectly employed by any of them, or anyone for whose acts any of them may be liable, except where caused by the active negligence, sole negligence, or willful misconduct of the DISTRICT.
- b. CONTRACTOR further agrees to investigate, handle, respond to, provide defense for and defend any such claims, etc., at his/her/its sole expense and agrees to bear all other costs and expenses related thereto.
- c. CONTRACTOR's responsibility for defense and indemnity obligations shall survive the termination or completion of this Contract for the full period of time allowed by law.
- d. The defense and indemnification obligations of the Contract are undertaken in addition to, and shall not in any way be limited by, the insurance obligations contained in this Contract.

10. Subcontracting:

- a. CONTRACTOR shall comply with the Subletting and Subcontracting Fair Practices Act of Public Contracts Code Sections 4100 et seq.
- b. CONTRACTOR shall submit to the DISTRICT the following information as part of its bid proposal:
 1. The name and location of the place of business of each subcontractor performing work, labor or rendering construction services and each subcontractor licensed by the State of California specially fabricating and installing improvements according to detailed drawings or the plans and specifications, in an amount in excess of one-half of one percent of the CONTRACTOR's total bid.
 2. The portion of the Work to be done by each subcontractor.
- c. CONTRACTOR shall list only one subcontractor for each portion of the Work identified in the bid.

- d. CONTRACTOR shall include in all subcontracts and require of all subcontractors all insurance and indemnity requirements and provisions of the Contract that are applicable to any subcontractor's scope of work. Subcontractor's responsibility for defense and indemnity obligations shall survive the termination or completion of this Contract for the full period of time allowed by law.
 - e. Each subcontractor shall be obligated to CONTRACTOR and the DISTRICT in the same manner and to the same extent as CONTRACTOR is obligated to the DISTRICT under the Contract Documents. If hiring a sub-subcontractor to perform any Work, the subcontractor shall include in the sub-subcontract all provisions of the Contract Documents including all insurance and indemnity provisions that are applicable to said sub-subcontractor's scope of work.
 - f. CONTRACTOR shall furnish a copy of the Contract insurance and indemnity provisions to any subcontractor upon request. Upon request from the DISTRICT, CONTRACTOR shall provide insurance certificates and endorsements of its subcontractors.
11. Registration with Department of Industrial Relations: CONTRACTOR and all subcontractors shall be currently registered with the Department of Industrial Relations pursuant to Labor Code section 1725.5.
12. Prevailing Wages: This project is subject to compliance monitoring and enforcement by the Department of Industrial Relations. A determination of the general prevailing rates of per diem wages and holiday and overtime work where the work is to be performed is available for review upon request at DISTRICT's Main office, 601 Startare Drive Eureka Ca 95501. CONTRACTOR and subcontractors will not pay less than the prevailing rates of wages. CONTRACTOR will post one copy of the prevailing rates of wages at the job site. The statutory provisions for penalties for failure to comply with state's wage and hour laws will be enforced (Labor Code § 1813). CONTRACTOR shall forfeit as penalty to the DISTRICT the sum of up to two hundred dollars (\$200.00) for each calendar day or portion thereof, and for each worker paid less than the prevailing rates under the contract.
13. Payroll Records:
- a. Pursuant to California Labor Code Section 1776, CONTRACTOR and each subcontractor shall keep accurate payroll records, showing the name, address, social security number, work classification, straight time and overtime hours worked each day and week, and the actual per diem wages paid to each journeyman, apprentice, worker, or other employee employed by him or her in connection with the work. Each payroll record shall contain or be verified by a written declaration that it is made under penalty of perjury, stating both of the following:
 - 1. The information contained in the payroll record is true and correct.
 - 2. The employer has complied with the requirements of Labor Code Sections 1771, 1811, and 1815 for any work performed by his or her employees on the public work project.

- b. The payroll records enumerated under paragraph (a) shall be certified and shall be available for inspection at all reasonable hours at the principal office of the CONTRACTOR on the following basis:
1. A certified copy of an employee's payroll record shall be made available for inspection or furnished to the employee or his or her authorized representative on request.
 2. A certified copy of all payroll records enumerated on paragraph (a) shall be made available for inspection or furnished upon request to the DISTRICT, the Division of Labor Standards Enforcement, and the Division of Apprenticeship Standards of the Department of Industrial Relations.
 3. A certified copy of all payroll records enumerated in paragraph (a) shall be made available upon request by the public for inspection or for copies thereof. However, a request by the public shall be made through either the DISTRICT, the Division of Apprenticeship Standards, or the Division of Labor Standards Enforcement. If the requested payroll records have not been provided pursuant to paragraph (b)(2), the requesting party shall, prior to being provided the records, reimburse the costs of preparation by the CONTRACTOR, subcontractors, and the entity through which the request was made. The public shall not be given access to the records at the principal office of the CONTRACTOR.
- c. The certified payroll records shall be on forms provided by the Division of Labor Standards Enforcement or shall contain the same information as provided by the division.
- d. The CONTRACTOR or subcontractor shall file a certified copy of the records enumerated in paragraph (a) with the entity that requested the records within ten days after receipt of a written request.
- e. Any copy of records made available for inspection as copies and furnished upon request to the public or any public agency by the DISTRICT, the Division of Apprenticeship Standards, or the Division of Labor Standards Enforcement shall be marked or obliterated in such a manner as to prevent disclosure of an individual's name, address, and social security number. The name and address of the CONTRACTOR awarded the contract or the subcontractor performing the contract shall not be marked or obliterated.
- f. Agencies included in the Joint Enforcement Strike Force on the Underground Economy and other law enforcement agencies investigating violations of law shall, upon request, be provided nonredacted copies of certified payroll records. The CONTRACTOR shall not be liable for damages due to good faith compliance with this subdivision.

- g. CONTRACTOR shall inform the DISTRICT of the location of the records enumerated under paragraph (a), including the street address, DISTRICT and county, and shall, within five working days, provide a notice of change of location and address.
 - h. The CONTRACTOR or subcontractor shall have ten days in which to comply subsequent to receipt of written notice requesting the records enumerated in paragraph (a). In the event that the CONTRACTOR or subcontractor fails to comply within the 10-day period, he or she shall, as a penalty to the DISTRICT, forfeit \$100 for each calendar day, or portion thereof, for each worker until strict compliance is effectuated. Upon the request of the Division of Labor Standards Enforcement, these penalties shall be withheld from progress payments then due. CONTRACTOR is not subject to a penalty assessment pursuant to this section due to a failure of a subcontractor to comply with this section.
 - i. The CONTRACTOR and each subcontractor shall furnish all personnel records specified in Labor Code section 1776, as described in this section 13, directly to the Labor Commissioner at least monthly, or more frequently if specified in this contract, and in a format prescribed by the Labor Commissioner.
14. Audit of Records: CONTRACTOR shall maintain complete and accurate records of all payrolls, expenditures, disbursements and other cost items charged to the DISTRICT or establishing the basis for an invoice, for a minimum of three years from the date of final payment to CONTRACTOR. All such records shall be clearly identifiable. CONTRACTOR shall allow DISTRICT representatives to inspect, examine, copy and audit such records during regular business hours upon 24 hours' notice.
15. Hours of Work:
- a. Eight hours labor constitutes a legal day's work. Workers shall be paid at a rate of one and one-half times the basic rate of pay for work in excess of eight hours during a calendar day or 40 hours during a calendar week of the foregoing hours.
 - b. CONTRACTOR shall keep and make available an accurate record showing the name each worker and hours worked each day and each week by each worker.
 - c. As a penalty, CONTRACTOR shall forfeit twenty-five dollars (\$25.00) for each worker, including subcontractors' workers, for each calendar day during which the worker is required or permitted to work more than eight hours in any one calendar day and 40 hours in any one calendar week in violation of Labor Code Sections 1810 through 1815.
16. Document Submission and Title to Documents: All documents, reports, plans, specifications, maps, estimates, manuscripts, drawings, descriptions and other final work products compiled under this Contract must be submitted electronically in MS Word and PDF formats and in hard copy format. Additionally, upon payment of fees and expenses due, title to all such documents shall be vested in the DISTRICT.

17. Materials and Equipment:

- a. Unless otherwise specified, shown, or permitted by the DISTRICT, materials and equipment incorporated in the Work shall be new. The DISTRICT may request the CONTRACTOR to furnish manufacturer's certificates to this effect.
- b. The CONTRACTOR must furnish adequate equipment and facilities to properly perform the Work in a workmanlike manner in accordance with specifications set forth in this Contract. Such equipment and facilities must be in a good state of repair and maintained in such state during the progress of the Work and shall meet requirements of applicable ordinances and laws. No worn or obsolete equipment shall be used, and in no case shall the manufacturer's rating for equipment be exceeded.
- c. Materials furnished and Work performed shall be subject to inspection and testing by DISTRICT's authorized agents at DISTRICT's expense. If such inspection and testing reveals non-compliance with the requirements of this contract, the CONTRACTOR shall bear the cost of necessary corrective measures and the cost of subsequent inspecting and testing.
- d. The inspection of the Work shall not relieve the CONTRACTOR of the obligations under the contract. Even though equipment, materials, or Work required under the Contract have been inspected, accepted, and estimated for payment, the CONTRACTOR shall replace or repair such equipment, materials, or Work found to be defective or otherwise not to comply with the requirements of the contract up to the end of the maintenance and guarantee period.
- e. Materials for use in the Work shall be stored by CONTRACTOR to prevent damage from exposure to the elements, admixture of foreign materials or from any other cause. CONTRACTOR is responsible for damage to or loss of materials by weather or other causes.

18. Permits and Licenses: Prior to execution of the Contract, CONTRACTOR shall obtain and maintain throughout the contract period a valid business license. CONTRACTOR shall apply for and procure permits and licenses necessary for the Work. CONTRACTOR shall give notices necessary and incidental to the due and lawful prosecution of the Work and shall comply duly with the terms and conditions of permits and licenses. CONTRACTOR shall pay charges and fees in connection with permits and licenses.

19. Contractor Qualifications and Standard of Work: CONTRACTOR warrants that it is fully qualified to perform the Work, and holds all applicable licenses, permits, and other necessary qualifications. CONTRACTOR shall perform and complete in a good and workmanlike manner all the Work described in the Contract Documents, to furnish at its cost and expense all tools, equipment, labor and materials necessary therefor, except such materials as are specifically stipulated in the Contract Documents to be furnished by DISTRICT, and to do everything required by this Contract and other contract documents. CONTRACTOR shall possess a valid Class "A" (contractor license), or the appropriate special California contractor's license at the time of bid submission and for the duration of

the Contract. CONTRACTOR shall be responsible for complying with all applicable local, state, and federal laws and regulations whether or not expressly stated or referred to herein. Only competent workers shall be employed on the Work. Workers who are incompetent, intemperate, troublesome, disorderly or otherwise objectionable, or who fail to perform Work properly and acceptably, shall be immediately removed from the Work by the CONTRACTOR and not re-employed.

20. Apprentices: CONTRACTOR shall comply with the Labor Code concerning the employment of apprentices.

21. Supervision of Work by Contractor: Before starting the Work, CONTRACTOR shall designate, in writing, a representative having authority to act for CONTRACTOR, and may designate an alternate representative. The representative or alternate shall be present at the work site when Work is in progress. Orders or communications given to this representative shall be deemed delivered to the CONTRACTOR. In the absence of the CONTRACTOR or designated representative, directions or instructions may be given by the DISTRICT Representative to the superintendent or foreman having charge of the specific work to which the order applies. Such order shall be complied with promptly and referred to the CONTRACTOR or the representative.

22. District Representative: The DISTRICT Representative, as designated by the DISTRICT Executive Director for the DISTRICT (“DISTRICT Representative”), shall decide questions about the quality of materials furnished and Work performed, manner of performance, rate of progress of the Work, interpretation of the plans and specifications, and the fulfillment of the Contract by the CONTRACTOR.

23. Inspection:

- a. The DISTRICT Representative shall have access to the Work during construction and shall be furnished with reasonable facility for gaining knowledge of the progress, workmanship and character of materials used and employed in the work.
- b. When the CONTRACTOR varies the period during which Work is carried on each day, CONTRACTOR shall give notice to the DISTRICT Representative so proper inspection may be provided. Work done in the absence of the DISTRICT Representative is subject to rejection.
- c. No materials shall be installed until approved by the DISTRICT Representative. Installations to be backfilled shall be inspected and approved by the DISTRICT Representative prior to backfilling. The CONTRACTOR shall give notice in advance of backfilling to the DISTRICT Representative so proper inspection may be provided.
- d. The inspection of the Work shall not relieve the CONTRACTOR of obligations to fulfill the contract. Defective Work shall be made good, and unsuitable materials may be rejected notwithstanding the fact such defective Work and unsuitable materials have been previously overlooked by the DISTRICT Representative and accepted.

24. Removal of Defective and Unauthorized Work:

- a. Rejected Work shall be removed and replaced by CONTRACTOR in an acceptable manner and no compensation will be allowed for such removal or replacement. Work done beyond the lines and grades shown on the plans or established by the DISTRICT Representative, or Work done without written authority will be considered as unauthorized and not be paid for. Such Work may be ordered removed at CONTRACTOR's expense.
- b. Upon failure on the part of CONTRACTOR to comply promptly with an order of the DISTRICT Representative under this section, the DISTRICT Representative shall have authority to cause defective Work to be removed and replaced, and unauthorized Work to be removed, and to deduct the costs from monies due CONTRACTOR.

25. Errors Or Discrepancies Noted By Contractor:

- a. If the CONTRACTOR finds discrepancy between the specifications and the drawings, and the physical conditions at the site of the Work or finds errors or omissions in the drawings or in any survey, CONTRACTOR shall promptly notify the DISTRICT in writing of such discrepancy, error or omission. If the CONTRACTOR observes drawings or specifications at variance with applicable law, ordinance, regulation, order or decree, CONTRACTOR shall promptly notify the DISTRICT in writing of such conflict.
- b. On receipt of any such notice, the DISTRICT shall promptly investigate the circumstances and give appropriate instructions to the CONTRACTOR. Until such instructions are given, Work done by the CONTRACTOR, after CONTRACTOR's discovery of such error, discrepancy or conflict will be at CONTRACTOR's own risk and CONTRACTOR shall bear costs arising therefrom.

26. Cleanup:

On completion of the Work, CONTRACTOR shall remove debris and surplus materials from the work site.

27. Guarantees:

CONTRACTOR guarantees Work from defect in workmanship for the period of one year from the date of acceptance by the DISTRICT and shall repair and replace such Work, together with other displaced work, without expense to the DISTRICT, ordinary wear and tear, usual abuse or neglect excepted. DISTRICT may have the defects repaired and made good at the expense of the CONTRACTOR, if CONTRACTOR fails to comply with the above-mentioned conditions within a week after being notified in writing.

28. Safety:

CONTRACTOR and subcontractors shall comply with the provisions of the Safety and Health Regulations for Construction, promulgated by the Secretary of Labor under the Contract Work Hours and Safety Standards Act, as set forth in Title 29, C.F.R. and by the California Division of Industrial Safety. CONTRACTOR shall take all precautions necessary for the safety and prevention of damage to property on/or adjacent to the

work site, and for the safety of and prevention of injury to persons, including DISTRICT's employees, CONTRACTOR's employees, and third persons, on/or adjacent to the work site.

29. Termination: Contractor at Fault:

- a. The DISTRICT shall have the right to terminate the CONTRACTOR for cause under any one or more of the following circumstances:
 1. CONTRACTOR's persistent failure to perform the Work in accordance with the Contract Documents (including, but not limited to, failure to supply sufficient skilled workers or suitable materials or equipment, failure to adhere to the progress schedule as approved from time-to-time by the DISTRICT Representative, failure to adhere to the schedule of values as approved from time-to-time by the DISTRICT Representative);
 2. CONTRACTOR's disregard of applicable laws and regulations;
 3. CONTRACTOR's repeated disregard of the authority or orders of the DISTRICT Representative;
 4. CONTRACTOR's repeated or persistent default of any of the provisions of the Contract Documents;
 5. CONTRACTOR's material breach of any provision of the Contract Documents;
 6. CONTRACTOR's failure to perform Work for a period of five consecutive work days unless such failure is excused because of inclement weather or Uncontrollable Circumstance.

- b. If one or more of the grounds for termination exist, the DISTRICT, after giving the CONTRACTOR and the performance surety five days written notice, may at its sole discretion, without liability for trespass or conversion, take any of the following actions: terminate the service of the CONTRACTOR; exclude the CONTRACTOR from the site; take possession of the site and Work; take possession of all of CONTRACTOR's tools, appliances, construction equipment, and machinery at the site; take possession of all materials and component parts, equipment, or machinery stored at the site or for which the CONTRACTOR has paid but which are stored elsewhere; use the site, tools, appliances, construction equipment, machinery, parts, and materials to the full extent they could be used by CONTRACTOR; finish the Work as the DISTRICT may deem expedient; or make demand on the performance bond surety to complete the Work. When the DISTRICT terminates CONTRACTOR's services under this Section, CONTRACTOR shall not be entitled to receive further payments until the Work is completed. If the unpaid balance of the Contract Price is greater than all claims, costs, losses, offsets and damages (including without limitation all fees and charges of engineers, architects, land surveyors, contractors and other providers of professional services) sustained by the DISTRICT arising out of or relating to completing the Work or

exercising its rights under this Section, the excess will be paid to CONTRACTOR or the performance bond surety. If the unpaid balance of the Contract Price is less than all claims, costs, losses, offsets and damages (including without limitation all fees and charges of engineers, architects, land surveyors, contractors and other providers of professional services) sustained by the DISTRICT arising out of or relating to completing the Work or exercising its rights under this Section, CONTRACTOR will pay the difference to the DISTRICT. When exercising any rights or remedies under this Section, the DISTRICT shall not be required to obtain the lowest price for the Work performed.

- c. The termination of CONTRACTOR's services under this paragraph will not affect any rights or remedies the DISTRICT may have against CONTRACTOR existing at the time of termination or which may later accrue. Any release of retention or payment by the DISTRICT will not release CONTRACTOR from liability.

30. Termination: Contractor Not at Fault:

- a. Upon five days' written notice to CONTRACTOR, the DISTRICT may, without cause and without prejudice to any other of the DISTRICT's rights or remedies, terminate the Contract.
- b. Upon the service of a notice of contract termination, CONTRACTOR shall discontinue the Work in the manner, sequence, and at such times as directed by the DISTRICT Representative. CONTRACTOR shall remain responsible for the quality and fitness of the Work performed by CONTRACTOR before termination of the Contract. All requirements of the Contract pertaining to Work completed or to be completed as directed by the DISTRICT Representative as of the time of termination shall survive the termination, including without limitation, all indemnities, warranties, requirements for preparation of record drawings and completion of any "punch-list" items directed by the DISTRICT Representative. CONTRACTOR shall cooperate with DISTRICT with respect to providing information about the work in progress at the time of termination, as requested by the DISTRICT Representative.
- c. Upon termination of the Contract, DISTRICT shall use reasonable efforts to determine and pay to CONTRACTOR within 90 days, without duplication, for the following items:
 - 1. For completed and acceptable Work executed in accordance with the contract Documents before the effective date of termination, including a fair and reasonable amount for overhead and profit on such Work, less any prior payments for the Work. The determined value of the Work, including overhead and profit, shall be consistent with the Contract Documents, including any schedule of payments or schedule of values.
 - 2. For documented direct expenses sustained before the effective date of termination in performing services or furnishing labor, materials, or equipment as required by the Contract Documents necessary for the execution of the uncompleted Work. The determined value of the

documented direct expenses, including overhead and profit, shall be consistent with the Contract Documents, including any schedule of payments or schedule of values.

3. For reasonable and documented direct expenses, including damages, incurred in settlement or as a consequence of terminated subcontracts;
 4. For other actual expenses reasonably incurred as a direct consequence of the termination
- d. Notwithstanding the foregoing, CONTRACTOR shall not be entitled to recover any loss of anticipated profit or revenue or other economic loss arising out of or resulting from the termination, including without limitation any claim for anticipated profits on the Work not performed or lost business opportunity.
 - e. If the CONTRACTOR is terminated under this Section, the DISTRICT may purchase from the CONTRACTOR all consumable supplies of the CONTRACTOR on hand, or in transit, or on definite commitment, including fuel, lubricants, and materials of construction not incorporated in the Work which, in the opinion of the DISTRICT Representative, are suitable and required to complete the Work; and the DISTRICT shall pay to the CONTRACTOR for such consumable supplies the prices paid therefore by the CONTRACTOR.
 - f. If the CONTRACTOR is terminated under this Section, upon request by the DISTRICT Representative, the CONTRACTOR shall provide the DISTRICT Representative with an itemized inventory and cost account of all plant, tools, equipment, labor and consumable supplies that have been used, are then in use, and were planned to be used on the Work. Further, upon request, the DISTRICT shall have the right to audit all of the CONTRACTOR's records relating to costs incurred or planned to be incurred in performing the Work.
31. Authority to Execute this Contract: The person or persons executing this Contract on behalf of CONTRACTOR warrants and represents that he/she has the authority to execute this Contract on behalf of CONTRACTOR and has the authority to bind CONTRACTOR to the performance of its obligations hereunder.
32. Representations: The parties acknowledge and agree that neither of them has made any representation with respect to the subject matter of this Contract or any representations inducing the execution and delivery hereof except such representations as are specifically set forth herein; and each party acknowledges that it has relied on its own judgment in entering into this Contract. The parties further acknowledge that any statements or representations that may have heretofore been made by either of them to the other are void and of no effect and that neither of them has relied thereon in connection with its dealings with the other.
33. Notices: Any notice or instrument required to be given or delivered by this contract may be given by depositing the same in any United States Post Office, registered or certified, postage prepaid, address to:

To: Humboldt Bay Harbor, Recreation, and Conservation District
Attn: Executive Director
PO Box 1030
Eureka Ca 95502

To Contractor: _____

34. **Assignment:** CONTRACTOR shall not assign this contract or payments under this contract. CONTRACTOR and each subcontractor hereby assign to the DISTRICT rights, title, and interest in and to causes of action under Section 4 of the Clayton Act (15 U.S.C.A. Sec. 15) or under the Cartwright Act (Chapter 2 commencing with Section 16700 of Part 2 of Division 7 of the California Business and Professions Code), arising from purchases of goods, services, or materials for this contract or the subcontract. This assignment shall be made and become effective without further acknowledgement by the parties at the time DISTRICT tender's final payment to CONTRACTOR.
35. **Amendment:** No waiver or modification of this Contract shall be valid unless agreed upon and signed by both the DISTRICT and CONTRACTOR.
36. **Nondiscrimination:** CONTRACTOR shall ensure equal employment opportunity for all persons, regardless of race, color, religion, sex, creed, national origin, ancestry, age, medical condition, physical or mental disability, Vietnam-era veteran or special disabled veteran status, marital status or citizenship, within the limits imposed by law. These principles are to be applied by CONTRACTOR in all employment practices including recruiting, hiring, transfers, promotions, training, compensation, benefits, layoffs, and terminations. CONTRACTOR agrees to comply with Title VII of the Civil Rights Act of 1964, as amended, the California Fair Employment Practices Act, the Americans With Disabilities Act of 1990, and any other applicable federal and state laws and regulations pertaining to nondiscrimination.
37. **Uncontrollable Circumstances:**
- a. Upon CONTRACTOR's written request and submission of substantiating documentation of a delay resulting from an Uncontrollable Circumstance, the DISTRICT Representative shall give CONTRACTOR a non-compensable extension of time. CONTRACTOR shall submit a written request within seven days of the commencement of the Uncontrolled Circumstance.
 - b. Prior to completion and acceptance of the Work, CONTRACTOR is responsible for, and bears the risk of loss associated with, damage or loss to any portion of the Work regardless of the cause, except that CONTRACTOR may request an extension of any required Completion Date specified, as set forth in Section 36(a). CONTRACTOR shall repair or replace such damages or destroyed Work to its prior undamaged condition before being entitled to additional progress payments or final payment. Total or partial destruction or damage shall not excuse CONTRACTOR from completion of Work.

- c. “Uncontrollable Circumstance” means any act, event or condition that is:
- beyond the reasonable control of the CONTRACTOR that justifies CONTRACTOR not timely performing an obligation or complying with any condition required under the contract documents, and
1. materially expands the scope of, interferes with, or delays the CONTRACTOR’s performance of obligations under the contract documents, but only if such act, event or condition is not the result of the willful or negligent act, error or omission, failure to exercise reasonable diligence, or breach of the contract documents on the part of the Contractor.
- d. materially expands the scope of, interferes with, or delays the CONTRACTOR’s performance of obligations under the contract documents, but only if such act, event or condition is not the result of the willful or negligent act, error or omission, failure to exercise reasonable diligence, or breach of the contract documents on the part of the CONTRACTOR. Examples of acts, events or conditions that typically qualify as uncontrollable circumstances include: naturally occurring events such as landslides, underground movement, earthquakes, fires, tornadoes, hurricanes, floods, lightning, epidemics, and extreme weather that threatens worker safety, property and/or project integrity in CONTRACTOR’s sole determination; explosions, terrorism, sabotage, or similar acts of a declared public enemy; extortion; war; blockade; insurrection, riot or civil disturbance; labor disputes, except labor disputes involving employees of the CONTRACTOR, its affiliates, or subcontractors, vendors and suppliers; the failure of any subcontractor to furnish services, materials, chemicals or equipment on the dates agreed to, but only if such failure is the result of an event that would constitute an uncontrollable circumstance if it affected CONTRACTOR directly, and CONTRACTOR is not able after exercising all reasonable efforts to timely obtain substitutes; the preemption, confiscation, diversion, destruction or other interference in possession or performance of materials or services by a government agency in connection with a public emergency or any condemnation or other taking by eminent domain of any material portion of the Work.
- e. Examples of acts, events or conditions that do not typically qualify as an uncontrollable circumstances include: weather conditions normal for the area where the Work is being performed; any delay that would not have occurred but for the CONTRACTOR’s failure to comply with its obligations under the contract documents; CONTRACTOR’s inability to obtain timely materials or equipment; any work related injuries, accidents or safety violations; any changes in interest rates, inflation rates, wage rates, insurance premiums, commodity prices, currency values, exchange rates or other general economic conditions that significantly increase CONTRACTOR’s cost of performing the Work; any change in the financial condition of the CONTRACTOR or any subcontractor affecting their ability to perform timely their respective obligations; the consequences of error, neglect or omissions by the CONTRACTOR, any subcontractor, or any other person in the performance of the Work; any change of union or labor work rules, requirements or

demands which have the effect of increasing the number of employees employed on the Work or otherwise increasing the cost to the CONTRACTOR of performing the Work; inclement weather conditions normal for the area where the Work is being performed; any mechanical failure of equipment; or any electric utility power outages except as a direct result of an independent uncontrollable circumstance.

38. Extra, Changed Work:

- a. The DISTRICT may require changes in, additions to, or deductions from the Work to be performed or to the materials to be furnished under this contract. No extra work shall be performed or change made except pursuant to a written order from the DISTRICT stating the extra work or change is authorized, and setting forth the basis upon which payment is to be made. No claim for additional compensation shall be valid unless pursuant to such a change order. Nothing in this section shall excuse the CONTRACTOR from proceeding with the prosecution of the changed work. When required by the DISTRICT, the CONTRACTOR shall furnish an itemized breakdown of the quantities and prices used in computing the value of any ordered change.
- b. Adjustments in the amounts to be paid to the CONTRACTOR by reason of any such change, addition or deduction shall be determined by one or more of the following methods:
 1. By an acceptable lump sum proposal from the CONTRACTOR.
 2. By unit prices contained in the CONTRACTOR's original bid and incorporated in the contract documents or fixed by subsequent agreement between the DISTRICT and the CONTRACTOR.
 3. By ordering the CONTRACTOR to proceed with the work and to furnish daily reports of extra work. The reports shall itemize all costs for labor, material, and equipment rental. The reports for workers shall include hours worked, rates of pay, names and classification; and for equipment shall include size, type, identification number and hours of operation. Records and reports shall be made immediately available to the DISTRICT Representative upon his request.
- c. When the DISTRICT orders extra work and there is an agreement between the DISTRICT and the CONTRACTOR to perform the extra work, the DISTRICT may approve the method used by the CONTRACTOR to accomplish the work. At the request of the DISTRICT, the method to be used shall be memorialized in writing prior to work being performed.

39. Governing Law and Venue: This Contract and performance hereunder and all suits and special proceedings shall be construed in accordance with the laws of the State of California. If any action is brought to enforce the terms of this contract it shall be brought in Humboldt County Superior Court.

40. Attorney's Fees: Should any litigation or arbitration be commenced between the parties hereto concerning this contract, or the rights and duties of any party in relation thereto, the party prevailing in such litigation or arbitration shall be entitled, in addition to such other relief as may be granted to a reasonable sum as and for attorney's fees in such litigation or arbitration.

This Contract contains the sole and entire agreement between the parties. It supersedes any and all other agreements between the parties.

Executed in Eureka, California on _____(date)

DISTRICT:
By: Chris Mikkelsen
Executive Director

Signature: _____

Date: _____

Board of Commissioners, Board President

Signature _____

Date: _____

CONTRACTOR:

Firm Name: _____

By: _____

Signature: _____

Title: _____

Date: _____

Address: _____

Email: _____

Phone : _____

Contractor's License #: _____

Employer Tax ID#: _____

DIR ID #: _____

INSERT INSURANCE FORMS

(CONTRACT AGREEMENT PACKAGE)

PERFORMANCE BOND

WHEREAS, the Humboldt Bay Harbor, Recreation and Conservation District, County of Humboldt, State of California, by motion passed _____, 20 __, has awarded to _____

hereinafter designated as the "Principal," a contract for constructing

Fields Landing Boat Yard, Stormwater Treatment System

AND WHEREAS, said Principal is required under the terms of said contract to furnish a bond for the faithful performance of said contract,

NOW THEREFORE, we,

_____ as Principal, and _____, as Surety, are held and firmly bound unto the Humboldt Bay Harbor, Recreation and Conservation District, California, hereinafter called the "Owner," to the penal sum of

_____ Dollars (\$ _____) lawful money of the United States of America, for which sum well and duly to be made, we bind ourselves, our heirs, executors, administrators, and successors, jointly and severally, firmly by these presents.

THE CONDITION OF THIS OBLIGATION IS SUCH that if the hereby bounded Principal, his or its heirs, executors, administrators, successors, or assigns shall in all things stand to and abide by and well and truly keep and perform all the undertakings, terms, covenants, conditions, and agreements in the said contract and any alteration thereof, made as therein provided, all within the time and in the manner therein designated and in all respects according to their true intent and meaning, then this obligation shall become null and void; otherwise, it shall be and remain in full force and virtue.

FURTHER, THE SAID SURETY, FOR VALUE RECEIVED, HEREBY STIPULATES AND AGREES that no change, extension of time, or alteration or modification of the Contract Documents or of the work to be performed thereunder shall in any way affect its obligations on this bond, and it does hereby waive notice of any such change, extension of time, alteration, or modification of the Contract Documents or of work to be performed thereunder.

(CONTRACT AGREEMENT PACKAGE)

IN WITNESS WHEREOF five (5) identical counterparts of this instrument, each of which shall for all purposes be deemed an original thereof, have been duly executed by the Principal and Surety herein named, on the _____ day of _____, 20 __, the name and corporate seal of each corporate party being hereto affixed and these presents duly signed by its undersigned representative pursuant to authority of its governing body.

Principal

By _____

Title

Surety

By _____

Address of Surety

(CONTRACT AGREEMENT PACKAGE)

LABOR AND MATERIAL BOND

KNOW ALL MEN BY THESE PRESENTS: That
WHEREAS, the Humboldt Bay Harbor, Recreation and Conservation District, by motion passed
_____, 20 __, has awarded to

_____ ,
hereinafter designated as the "Principal," a contract for constructing

Fields Landing Boat Yard, Stormwater Treatment System

AND WHEREAS, said Principal is required to furnish a bond in connection with said contract, providing that if said Principal, or any of his or its subcontractors, shall fail to pay for any materials, provisions, provender, or other supplies or teams used in, upon, or about the performance of the work contracted to be done, or for any work or labor done thereon of any kind, the Surety on this bond will pay the same to the extent hereinafter set forth;

NOW THEREFOR, we, _____ ,

as Principal, and _____ ,

as Surety, are held and firmly bound unto the Humboldt Bay Harbor, Recreation and Conservation District, California, hereinafter called the "Owner," to the penal sum of _____ Dollars (\$ _____) lawful money of the United States of America, for the payment of which sum well and truly to be made, we bind ourselves, our heirs, executors, administrators, and successors, jointly and severally, firmly by these presents.

THE CONDITION OF THIS OBLIGATION IS SUCH that if said Principal, his or its subcontractors, heirs, executors, administrators, successors, or assigns shall fail to pay any of the persons named in Section 3181 of the Civil Code, or amounts due under the Unemployment Insurance Code with respect to work or labor performed by any such claimant, or for any amounts required to be deducted, withheld, and paid over to the Franchise Tax Board from the wages of employees of the contractor and his subcontractors pursuant to Section 18806 of the Revenue and Taxation Code with respect to such work and labor as required by Section 3247 et seq. of the Civil Code of California, then said Surety will pay for the same, in or to an amount not exceeding the amount hereinabove set forth, and also will pay in case suit is brought upon this bond such reasonable attorney's fees, as shall be fixed by the court, awarded and taxed as in the above-mentioned statutes provided.

(CONTRACT AGREEMENT PACKAGE)

FURTHER, the said Surety, for value received, hereby stipulates and agrees that no change, extension of time, or alteration or modification of the Contract Documents or of the work to be performed thereunder shall in any way affect its obligations on this bond, and it does hereby waive notice of any such change, extension of time, or alteration or modification of the Contract Documents or of work to be performed thereunder.

IN WITNESS WHEREOF five (5) identical counterparts of this instrument, each of which shall for all purposes be deemed an original thereof, have been duly executed by the Principal and Surety herein named, on the _____ day of _____, 20 ____, the name and corporate seal of each corporate party being hereto affixed and these presents duly signed by its undersigned representative pursuant to authority of its governing body.

Principal

By _____

Title

Surety

By _____

Address of Surety

NOTICE OF AWARD

TO: _____

PROJECT DESCRIPTION: Fields Landing Boat Yard, Stormwater Treatment System.

The Owner has considered the bid submitted by you for the above-described work in response to its Advertisement for Bids dated _____, 20____, and Information for Bidders.

You are hereby notified that your bid has been accepted for items in the amount of \$_____.

You are required by the Instructions to Bidders to execute the Agreement and furnish the required certificates of insurance within ten (10) calendar days from the date of receipt of this Notice.

If you fail to execute said Agreement and to furnish said certificates within ten (10) calendar days from the date of receipt of this Notice, said Owner will be entitled to consider all your rights arising out of the Owner's acceptance of your bid as abandoned. The Owner will be entitled to such other rights as may be granted by law.

You are required to return an acknowledged copy of this Notice of Award to the Owner.

Dated this _____ day of _____, 20____,

Owner: _____

By: _____

Title: _____

Owner's Representative

ACCEPTANCE OF NOTICE

Receipt of the above Notice of Award is hereby acknowledged by:

this, the _____ day of _____, 20____.

By: _____

Title: _____

NOTICE TO PROCEED

TO: _____

PROJECT DESCRIPTION: Fields Landing Boat Yard, Stormwater Treatment System.

You are hereby notified to commence work in accordance with the Agreement dated _____, 20____, on or before _____, 20____. The date of completion of all work shall be by _____, 20____.

(Humboldt Bay Harbor, Recreation & Conservation District)

By: _____

Title: _____

ACCEPTANCE OF NOTICE

Receipt of this above Notice to Proceed is hereby acknowledged by

_____ ,

this, the _____ day of _____, 20____.

By: _____

Title: _____

HUMBOLDT BAY HARBOR, RECREATION, AND CONSERVATION DISTRICT (HBHRCD)

FIELDS LANDING BOAT YARD STORMWATER TREATMENT SYSTEM

1 YARD ROAD, FIELDS LANDING, CALIFORNIA

PREPARED BY:



OCTOBER 2024



INDEX OF SHEETS	
SHEET	TITLE
G1.0	COVER
G2.0	STANDARD ABBREVIATIONS AND LEGENDS
G3.0	NOTES AND SPECIFICATIONS
C1.0	EXISTING CONDITIONS
C2.0	DEMOLITION PLAN
C3.0	SITE PLAN AND YARD PIPING
C3.1	ENLARGED SITE PLAN
C4.0	HYDRAULIC PROFILE
C5.0	TANK DETAILS
C6.0	TANK DETAILS
C7.0	DETAILS
C8.0	DETAILS

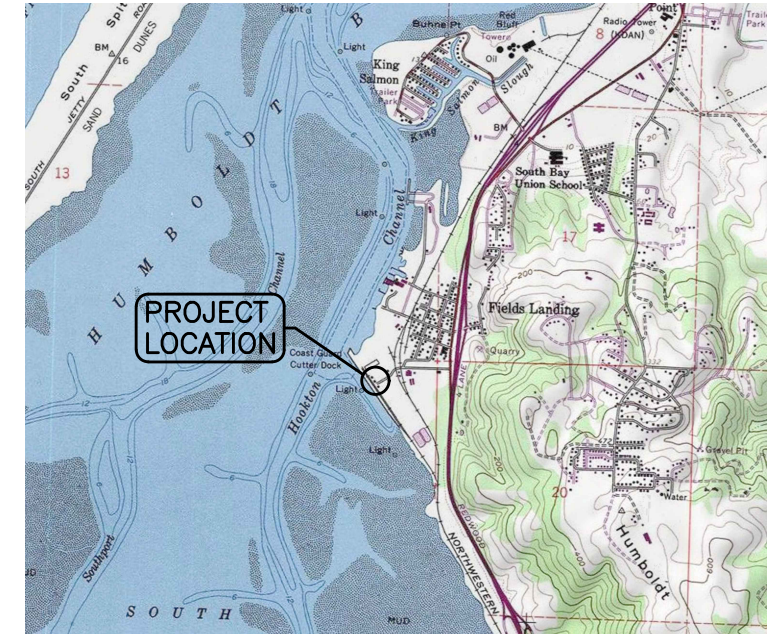

VERIFY SCALES
BAR IS ONE INCH ON ORIGINAL DRAWING
IF NOT ONE INCH ON THIS SHEET ADJUST SCALES ACCORDINGLY

812 W. WABASH AVE.
EUREKA, CA 95501
WWW.SW-ENR.COM
707-441-8885



NO.	DATE	REVISION	BY
1	05/28/2026	REVISION 1	MKF

DESIGN	JG
DR	CDN/JWF
CHK	CRS
APVD	

HBHRCD
FIELDS LANDING BOAT YARD STORMWATER TREATMENT SYSTEM
FIELDS LANDING, CALIFORNIA
COVER

SHEET	G1.0
SEQ	
DATE	10/2024
PROJ. NO.	016216.100



SAVED: 5/28/2026 12:53 PM JFOSTER, PLOTTED: 5/28/2026 12:53 PM JOHN FOSTER
F:\Eureka\2016\016216-HBHRCD-FL-IGP\Draws\016216-100-COVER.dwg

Agenda Item 11e.
Attachment B

ABBREVIATIONS	
A	
AC	ASPHALTIC CONCRETE OR ASBESTOS CEMENT
ACP	ASBESTOS CEMENT PIPE
AGGR	AGGREGATE
B	
BMP	BEST MANAGEMENT PRACTICE
C	
CONC	CONCRETE
D	
°	DEGREES
DI	DRAINAGE INLET
DIA	DIAMETER
DIP	DUCTILE IRON PIPE
E	
(E)	EXISTING
ELEV	ELEVATION
G	
GAL	GALLON
GALV	GALVANIZED
H	
HDPE	HIGH DENSITY POLYETHYLENE
I	
INV	INVERT
L	
LBS	POUNDS
M	
MAX	MAXIMUM
MIN	MINIMUM
N	
(N)	NEW
NO.	NUMBER
NTS	NOT TO SCALE
P	
PLCS	PLACES
PVC	POLYVINYL CHLORIDE
R	
RC	RELATIVE COMPACTION
RDCR	REDUCER
REQD	REQUIRED
S	
SCHED	SCHEDULE
SD	STORM DRAIN
SHT	SHEET
SS	SANITARY SEWER
SST	STAINLESS STEEL
STL	STEEL
T	
TYP	TYPICAL
T	TELECOMMUNICATIONS
W	
W	WATER

UTILITIES LEGEND

N	TIDEFLEX CHECK VALVE
— W —	WATER LINE
— SS —	SANITARY SEWER LINE
— SD —	STORM DRAIN LINE
— T —	TELECOMMUNICATIONS LINE
— E —	ELECTRICAL LINE

ABBREVIATIONS AND LEGEND NOTES

- CONTACT THE ENGINEER FOR SYMBOLS NOT LISTED.
- THIS IS A STANDARD SHEET, THEREFORE, SOME SYMBOLS OR ABBREVIATIONS MAY APPEAR ON THIS SHEET WHICH DO NOT APPEAR ON THE PLANS.
- SITE AND UTILITY SYMBOLS SHOWN ON THIS SHEET ARE NOT INTENDED TO REPRESENT THE PHYSICAL SCALE OR SHAPE OF ANY ITEMS. WHERE LARGE-SCALE PLANS ARE PRESENTED, THE SYMBOLS SHOWN HEREON MAY BE REPLACED BY DETAILS MORE SUITED TO THE DRAWING SCALE.

DETAIL AND SECTION DESIGNATION

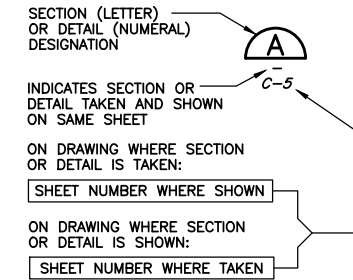

VERIFY SCALES BAR IS ONE INCH ON ORIGINAL DRAWING IF NOT ONE INCH ON THIS SHEET ADJUST SCALES ACCORDINGLY	
812 W. WABASH AVE. EUREKA, CA 95501 WWW.SFH-CR.COM 707-441-8865	
NO.	1
DATE	05/28/2026
REVISION	REVISION 1
BY	MAF
DESIGN	JG
DRAWING	CDN/JWF
CHECK	CRS
APPROVED	APVD
HBHRCD BOAT YARD STORMWATER TREATMENT SYSTEM FIELDS LANDING, CALIFORNIA STANDARD ABBREVIATIONS AND LEGENDS	
SHEET	G2.0
SEQ	
DATE	10/2024
PROJ. NO.	016216.100

GENERAL NOTES:

1. ALL WORK SHALL CONFORM TO CURRENT CALIFORNIA BUILDING CODE.
2. THE WORKING DRAWINGS ARE GENERALLY DIAGRAMMATIC. THEY DO NOT SHOW EVERY OFFSET, BEND OR ELBOW REQUIRED FOR INSTALLATION IN THE SPACE PROVIDED. THEY DO NOT SHOW EVERY DIMENSION, COMPONENT PIECE, SECTION, JOINT OR FITTING REQUIRED TO COMPLETE THE PROJECT. ALL LOCATIONS FOR WORK SHALL BE CHECKED AND COORDINATED WITH EXISTING CONDITIONS IN THE FIELD BEFORE BEGINNING CONSTRUCTION. EXISTING UNDERGROUND UTILITIES WITHIN THE LIMITS OF EXCAVATION SHALL BE VERIFIED AS TO CONDITION, SIZE AND LOCATION BY UNCOVERING, PROVIDED SUCH IS PERMITTED BY LOCAL PUBLIC AUTHORITIES WITH JURISDICTION, BEFORE BEGINNING CONSTRUCTION. CONTRACTOR SHALL NOTIFY ENGINEER OF ANY DISCREPANCIES.
3. THE CONTRACTOR SHALL SECURE ALL NECESSARY PERMITS PRIOR TO THE COMMENCEMENT OF CONSTRUCTION.
4. THE CONTRACTOR SHALL PROVIDE A COPY OF THE TRENCH PERMIT FROM THE CALIFORNIA DIVISION OF INDUSTRIAL SAFETY PRIOR TO THE EXCAVATION OF ANY TRENCH OVER FIVE FEET IN DEPTH.
5. CONTRACTOR SHALL PERFORM TRENCH WORK IN CONFORMANCE WITH THE CALIFORNIA DIVISION OF INDUSTRIAL SAFETY REQUIREMENTS AND SHALL CONFORM TO ALL APPLICABLE OCCUPATIONAL SAFETY AND HEALTH STANDARDS, RULES, REGULATIONS AND ORDERS ESTABLISHED BY THE STATE OF CALIFORNIA AND OTHER APPLICABLE AGENCIES.
6. CONTRACTOR AGREES THAT IN ACCORDANCE WITH GENERALLY ACCEPTED CONSTRUCTION PRACTICES, GENERAL CONTRACTOR WILL ASSUME SOLE AND COMPLETE RESPONSIBILITY FOR JOB SITE CONDITIONS DURING THE COURSE OF CONSTRUCTION OF THE PROJECT, INCLUDING SAFETY OF ALL PERSONS AND PROPERTY. ALL WORK AND EQUIPMENT SHALL COMPLY WITH THE CALIFORNIA DIVISION OF INDUSTRIAL SAFETY REQUIREMENTS. THIS REQUIREMENT SHALL BE MADE TO APPLY CONTINUOUSLY, AND NOT BE LIMITED TO NORMAL WORKING HOURS. CONTRACTOR FURTHER AGREES TO HOLD HARMLESS, INDEMNIFY AND DEFEND THE OWNER, THE ENGINEER AND HIS/HER CONSULTANTS.
7. THE CONTRACTOR SHALL INDEPENDENTLY REVIEW GROUND, TOPOGRAPHY AND TREE CONDITIONS THROUGHOUT THE SITE, AND ASSUME THE RISK OF COMPLETING THE WORK SET OUT ON THESE PLANS, REGARDLESS OF ROCK, WATER TABLE OR OTHER CONDITIONS WHICH MAY BE ENCOUNTERED IN THE COURSE OF THE WORK.
8. ANY DISCREPANCY DISCOVERED BY THE CONTRACTOR IN THESE PLANS, OR ANY FIELD CONDITIONS DISCOVERED BY THE CONTRACTOR THAT MAY DELAY OR OBSTRUCT THE PROPER COMPLETION OF THE WORK SHOWN HEREIN SHALL BE BROUGHT TO THE ATTENTION OF THE OWNER AND THE ENGINEER IMMEDIATELY UPON DISCOVERY. SAID NOTIFICATION SHALL BE IN WRITING.
9. ALL UNDERGROUND IMPROVEMENTS SHALL BE INSTALLED TESTED AND APPROVED PRIOR TO PAVING.
10. THE CONTRACTOR SHALL NOT BEGIN EXCAVATING UNTIL ALL EXISTING UTILITIES HAVE BEEN MARKED IN THE FIELD. THE CONTRACTOR SHALL NOTIFY EACH APPLICABLE ENTITY AT LEAST 48 HOURS PRIOR TO COMMENCING WORK. CALL UNDERGROUND SERVICE ALERT (USA) TWO WORKING DAYS BEFORE DIGGING AT (800) 227-2600 FOR LOCATES.
11. GRADING AND CONSTRUCTION CONTRACTORS SHALL STOP WORK AND NOTIFY THE OWNER AND THE ENGINEER IF CULTURAL RESOURCES ARE DISCOVERED DURING CONSTRUCTION.
13. THE CONTRACTOR SHALL GIVE THE INSPECTOR 48 HOURS ADVANCE NOTICE OF ANY CONSTRUCTION OR REQUIRED TESTING.
14. SHOULD THE CONTRACTOR OR ANY OF HIS AGENTS OR EMPLOYEES ENCOUNTER OR DISCOVER MATERIALS WHICH APPEAR TO BE HAZARDOUS DURING THE PERFORMANCE OF THE WORK, THE CONTRACTOR SHALL INFORM THE ENGINEER IMMEDIATELY AND SUSPEND WORK IN THE AFFECTED AREA UNTIL THE ENGINEER HAS INSPECTED THE LOCATION AND MATERIALS IN QUESTION. SHOULD IT BE NECESSARY TO UNDERTAKE REMEDIATION, THE ENGINEER WILL GIVE WRITTEN NOTICE TO SUSPEND WORK IN THE AFFECTED AREA UNTIL THE PROPER COURSE OF ACTION HAS BEEN DETERMINED. OPERATIONS IN THE AFFECTED AREA SHALL BE RESUMED ONLY UPON WRITTEN NOTICE BY THE ENGINEER.
15. THE TOPSOIL SHALL BE REMOVED FROM CUT AND FILL AREAS AND SHALL NOT BE USED FOR ENGINEERED FILL. TOPSOIL SHALL BE STOCKPILED SEPARATELY AND REPLACED OVER AREAS OF EXPOSED SUBGRADE TO A MINIMUM DEPTH OF 6 INCHES.
16. NO CHANGES OR MODIFICATIONS SHALL BE MADE TO THESE PLANS WITHOUT WRITTEN APPROVAL BY THE ENGINEER.

EROSION CONTROL NOTES:

1. BMPs SHALL BE INSTALLED PRIOR TO ANY SITE DISTURBANCE AND MAINTAINED SUCH THAT NO VISIBLE SEDIMENT LEAVES THE SITE.
2. TRACKING CONTROLS: ENTRANCE/EXIT BMP IN ACCORDANCE WITH CALIFORNIA STORMWATER QUALITY ASSOCIATION (CASQA) MANUAL.
3. PAVED AREAS AT THE ACCESS POINTS SHALL BE SWEEPED OR VACUUMED AS OFTEN AS EACH DAY TO ELIMINATE TRACKING SOIL AND DEBRIS BEYOND THE LIMITS OF THE PROJECT SITE. ANY SOILS AND/OR DEBRIS, ROCK, GRAVEL, ETC. TRACKED BEYOND THE LIMITS OF THE PROJECT SITE AS A RESULT OF THIS PROJECT SHALL BE REMOVED IMMEDIATELY.
4. DISTURBED AREAS SHALL BE PROTECTED TO EXTENT PRACTICAL DURING CONSTRUCTION.
5. STOCKPILE MANAGEMENT TO BE IMPLEMENTED USING BMPs AS DESCRIBED IN THE CALIFORNIA STORMWATER QUALITY ASSOCIATION MANUAL.
6. DISTURBED AREA SHALL BE STABILIZED AS SOON AS POSSIBLE.
7. THE CONTRACTOR SHALL NOT ALLOW ANY CONSTRUCTION DEBRIS TO ENTER THE STORM DRAIN OR SANITARY SEWER SYSTEMS. THE CONTRACTOR SHALL INSTALL APPROVED PHYSICAL BARRIERS TO ENSURE THAT ALL DEBRIS IS CAPTURED AND REMOVED FROM SURFACE RUNOFF PRIOR TO RELEASING SITE RUNOFF.

PROJECT SPECIFICATIONS:

GENERAL COMPACTION

1. COMPACTION REQUIREMENTS AS SPECIFIED WILL BE BY PERCENT OF THE MAXIMUM DRY DENSITY AND AS DETERMINED PER ASTM D 1557. THE IN-PLACE DENSITY SHALL BE DETERMINED BY ASTM 6938.
2. PLACE BACKFILL AND FILL SOIL MATERIAL IN LOOSE LIFTS OF NOT MORE THAN 8 INCHES FOR MATERIAL COMPACTED BY HEAVY EQUIPMENT, AND NOT MORE THAN 6 INCHES FOR MATERIAL COMPACTED BY HAND-OPERATED TAMPERS.
3. THE CONTRACTOR SHALL BE RESPONSIBLE TO CONFIRM THE GROUND ELEVATIONS AND OVERALL TOPOGRAPHY OF THE SITE PRIOR TO THE START OF CONSTRUCTION. THE CONTRACTOR SHALL NOTIFY SHN CONSULTING ENGINEERS AT 707-441-8855 IMMEDIATELY, AND PROVIDE WRITTEN DESCRIPTION OF ANY DIFFERENCES IN TOPOGRAPHY FROM THAT SHOWN ON THESE PLANS WHICH MAY REQUIRE CHANGES IN DESIGN AND/OR AFFECT EARTHWORK QUANTITY.
4. TOPSOIL SHALL BE REMOVED FROM ALL CUT AND FILL AREAS AND SHALL NOT BE USED FOR ENGINEERED FILL.
5. FILL MATERIALS SHALL COMPLY WITH THE REQUIREMENTS OF THESE PLANS UNLESS OTHERWISE SPECIFIED BY THE MANUFACTURER. ANY DISCREPANCY SHALL BE IMMEDIATELY BROUGHT TO THE ATTENTION OF THE ENGINEER PRIOR TO PROCEEDING WITH THE WORK.
6. COMPACTION IN TRENCHES SHALL BE TESTED EVERY 50 FEET WITH A MINIMUM OF TWO TESTS PER ANY LENGTH OF TRENCHING. THE ENGINEER WILL BE PERMITTED TO COMPLETE TESTING AT ANY BACKFILL ELEVATION DURING THE BACKFILLING PROCESS. THE CONTRACTOR SHALL PROVIDE EQUIPMENT AND AN OPERATOR, FREE OF CHARGE TO FACILITATE THE TESTING REQUIRED BY THE ENGINEER.
7. FILL MATERIALS SHALL BE MECHANICALLY COMPACTED. JETTING WILL NOT BE ALLOWED.
8. CARE SHALL BE TAKEN NOT TO CRUSH THE PIPE OR OTHER COMPONENTS WITH COMPACTION EQUIPMENT.
9. ENGINEER SHALL INSPECT AND APPROVE ALL SUBGRADE, BACKFILL, AND TRENCH WORK PRIOR TO PLACING SUBSEQUENT MATERIALS.

TESTING AND INSPECTION

1. ALL SITE GRADING, SUBGRADE, AND BACKFILLING WILL BE INSPECTED BY THE ENGINEER. CONTRACTOR TO PROVIDE 48 HOUR NOTICE IN ADVANCE OF REQUIRED INSPECTION. FAILURE TO GIVE ADEQUATE NOTICE MAY RESULT IN TESTING DELAYS WHICH WILL BE THE RESPONSIBILITY OF THE CONTRACTOR.
2. THE ENGINEER WILL MAKE ALL COMPACTION TESTS WHEN ADVISED BY THE CONTRACTOR THAT IN THE OPINION OF THE CONTRACTOR, SUFFICIENT DENSITIES HAVE BEEN ACHIEVED. THE CONTRACTOR SHALL FURNISH A BACKHOE AND OPERATOR UPON REQUEST AT NO COST TO OWNER.
3. THE CONTRACTOR SHALL MAKE ALL NECESSARY EXCAVATIONS FOR COMPACTION TESTS. COSTS OF EXCAVATION, BACKFILLING, AND COMPACTING IN CONNECTION WITH COMPACTION TESTING SHALL BE BORNE BY THE CONTRACTOR. A FAILING COMPACTION TEST INDICATES THAT THE REQUIRED COMPACTION STANDARDS HAVE NOT BEEN ACHIEVED. ANY FILL MATERIAL OR PORTION OF FILL MATERIAL THAT DOES NOT MEET THE SPECIFIED REQUIREMENTS SHALL BE REMOVED AND RECOMPACTED UNTIL THE REQUIREMENTS ARE SATISFIED AT NO ADDITIONAL COST TO THE OWNER. COSTS ASSOCIATED WITH RETESTING PREVIOUSLY FAILED AREAS SHALL BE PAID BY OWNER AND BACK-CHARGED TO THE CONTRACTOR.
4. EXCAVATIONS FOR COMPACTION TESTS SHALL BE BACKFILLED WITH MATERIAL SIMILAR TO THAT EXCAVATED, AND BE COMPACTED TO THE SPECIFIED DENSITY.
5. ALL COSTS ASSOCIATED WITH ACHIEVING COMPACTION STANDARDS SHALL BE INCLUDED IN THE BID PRICES PAID FOR THE BID ITEM INVOLVED AND THEREFORE NO ADDITIONAL COMPENSATION SHALL BE MADE.
6. PRESSURE/VACUUM TESTING OF MANHOLE AND CONNECTION TO TANK. VACUUM TEST IN ACCORDANCE WITH ASTM C1244 AND ASTM C1719.

PAVING

1. ALL ASPHALT CONCRETE SHALL BE IN ACCORDANCE WITH CALTRANS STANDARD SPECIFICATIONS SECTION 39.
2. ASPHALT MATERIAL SHALL BE HMA TYPE A WITH 1/2 INCH AGGREGATE GRADATION. ASPHALT BINDER SHALL BE PG64-16.
3. ASPHALT CONCRETE SHALL BE INSTALLED AND TESTED ACCORDING TO THE "STANDARD PROCESS" SPECIFIED IN SECTION 39 OF THE CALTRANS STANDARD SPECIFICATIONS. ACCEPTANCE CRITERIA PER CALTRANS TEST 309.
4. WHERE NEW PAVING MEETS EXISTING PAVEMENT, EXISTING PAVEMENT SHALL BE SAWCUT.
5. APPLY TACK COAT TO CONTACT SURFACES OF CURBS, GUTTERS AND EXISTING PAVEMENT.
6. PLACE ASPHALT CONCRETE WITHIN 24 HOURS OF APPLYING PRIMER OR TACK COAT.
7. TACK COAT SHALL BE TYPE SS-1.
8. COMPACT PAVEMENT BY ROLLING TO A MINIMUM OF 95% OF MAXIMUM DENSITY IN ACCORDANCE WITH CALTRANS TEST 375. DO NOT DISPLACE OR EXTRUDE PAVEMENT FROM POSITION. HAND COMPACT IN AREAS INACCESSIBLE TO MECHANICAL ROLLING EQUIPMENT.
9. PERFORM ROLLING WITH CONSECUTIVE PASSES TO ACHIEVE SMOOTH FINISH WITHOUT ROLLER MARKS.
10. AGGREGATE BASE SHALL BE CALTRANS CLASS 2, COMPACTED TO 95% RELATIVE COMPACTION PER ASTM D1557/D6938.
11. IN AREAS TO BE PAVED, MINIMUM TOP 6 INCHES OF SUITABLE NATIVE SOIL SHALL BE SCARIFIED AND RECOMPACTED TO 90% RELATIVE COMPACTION PER ASTM D1557/D6938.
12. UNLESS OTHERWISE SHOWN ON THESE PLANS, NEW ASPHALT CONCRETE SURFACES AND NEW FINISH GRADE SURFACES SHALL BE INSTALLED SO AS TO MAINTAIN EXISTING SURFACE DRAINAGE PATTERNS.

PIPING

1. ALL EXPOSED PVC PIPING SHALL BE PROTECTED FROM UV DAMAGE. COATING SYSTEM SHALL BE ACRYLIC LATEX SEMI-GLOSS 2 COAT 320 SF PER GALLON PER COAT. CONTRACTOR MAY USE UV PIPE WRAP IF APPROVED BY ENGINEER PRIOR TO USE.

BELOW GRADE TANKS

1. IF REQUIRED, GEOGRID SHALL BE TENSAR INTERAX NX750 OR APPROVED EQUAL.
2. STABILIZATION MATERIAL MAY BE REQUIRED BY ENGINEER IF SUBGRADE CANNOT PROVIDE UNYIELDING SURFACE. MATERIAL TO BE SPECIFIED BY ENGINEER.
3. ALL TANK PENETRATIONS TO INCLUDE LINK SEALS.
4. TANK JOINTS SHALL BE DOUBLE SEALED TONGUE AND GROOVE FOR HIGH GROUNDWATER CONDITIONS IN ACCORDANCE WITH JENSEN INSTALLATION PROCEDURES.
5. CONTRACTOR SHALL SUBMIT TANK SPECIFICATIONS TO ENGINEER PRIOR TO PURCHASE. ANTI-BUOYANCY MEASURES MAY BE REQUIRED AND SHALL BE INSTALLED AT NO ADDITIONAL COST TO THE OWNER.

PUMP STATION

1. PUMP, PUMP RAILS, CONTROL PANEL, FLOATS, VAULT, VAULT HATCH, INTERNAL PIPING, AND INTERNAL VALVES INCLUSIVE WITH PUMP VAULT PACKAGE.
2. JENSEN 460-S SERIES STANDARD SIMPLEX PUMP STATION, OR APPROVED EQUAL.

SUBMERSIBLE PUMP SPECIFICATIONS:

1. MODEL: GOULDS WS1512D4 (FLOAT INCLUDED) OR APPROVED EQUAL.
2. MINIMUM DESIGN PUMP CAPACITY: 180GPM @ 22 FT TDH.
3. POWER: 1 PHASE, 230 VOLTS, 9.5 AMP.
4. MINIMUM BREAKER SIZE: 20 A.
5. MINIMUM CORD LENGTH: 30 FEET.

GUIDE RAIL SPECIFICATIONS:

1. GOULDS GUIDE RAIL SYSTEM (4"); MODEL A1040SS OR APPROVED EQUAL.
2. GUIDE RAILS: 2" SCH 40 A312 SS STEEL; REFER TO PLANS FOR LENGTH.
3. GOULDS LIFTING CHAIN KIT: ACHN5S10KT OR APPROVED EQUAL.

FILTER SPECIFICATIONS:

1. MODEL: STORMWATER BIOCHAR 48S OR APPROVED EQUAL.
2. MEDIA: CAPPING LAYER (UPPER 5")- ZEOLITE
3. MEDIA: MID-LAYER (APPROX 30")- BIOCHAR PEAT
4. MEDIA: BOTTOM LAYER (BOTTOM 5")- ZEOLITE OR STORMWATER SHALE
5. INLET DIAMETER: 3 INCH
6. OUTLET DIAMETER: 3 INCH
7. SAMPLE PORT TO BE PROVIDED BY MANUFACTURER
8. COORDINATE WITH OWNER TO VERIFY RELATIVE POSITION OF PIPING AND FORKLIFT HOLES.

VERIFY SCALES
 BAR IS ONE INCH ON ORIGINAL DRAWING
 IF NOT ONE INCH ON THIS SHEET, ADJUST SCALES ACCORDINGLY

812 W. WABASH AVE.
 EUREKA, CA 95501
 WWW.SHN-ENR.COM
 707-441-8855



BY: MKF

REVISION

REVISION 1

DATE 05/28/2026

NO. 1

DESIGN JG
 DR CON/JWF
 CHK CRS
 APVD

HBHRCD
 FIELDS LANDING BOAT YARD STORMWATER TREATMENT SYSTEM
 FIELDS LANDING, CALIFORNIA

SHEET G3.0
 SEQ
 DATE 10/2024
 PROJ. NO. 016216.100

NOTES AND SPECIFICATIONS

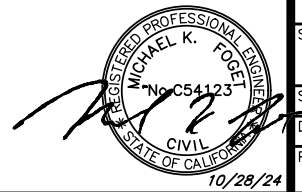



PLAN
 1"=40'

NOTE:
 LOCATIONS OF EXISTING UTILITIES ARE APPROXIMATE.
 CONTRACTOR SHALL LOCATE ALL UTILITIES PRIOR TO MOBILIZATION.



VERIFY SCALES BAR IS ONE INCH ON ORIGINAL DRAWING IF NOT ONE INCH ON THIS SHEET, CONSULT SCALES ACCORDINGLY			
812 W. WABASH AVE. EUREKA, CA 95501 WWW.SFH-ENR.COM 707-441-8865			
NO.	DATE	REVISION	BY
1	05/28/2026	REVISION 1	MKF
HIBHRCD FIELDS LANDING BOAT YARD STORMWATER TREATMENT SYSTEM FIELDS LANDING, CALIFORNIA		EXISTING CONDITIONS	
SHEET C1.0		SEQ	
DATE 10/2024		PROJ. NO. 016216.100	
DSGN JG DR CDN/JWF CHK CRS APVD		REGISTERED PROFESSIONAL ENGINEER MICHAEL K. FOGET No. C54123 CIVIL STATE OF CALIFORNIA 10/28/24	



PLAN
 1"=10'



VERIFY SCALES BAR IS ONE INCH ON ORIGINAL DRAWING IF NOT ONE INCH ON THIS SHEET, ADJUST SCALES ACCORDINGLY	
812 W. WABASH AVE. EUREKA, CA 95501 WWW.SFH.COM 707-441-8865	
NO.	BY
1	MKF
DATE	REVISION
05/28/2026	REVISION 1
DR	JG
CHK	CDN/JWF
APVD	CRS
HBHRCD FIELDS LANDING BOAT YARD STORMWATER TREATMENT SYSTEM FIELDS LANDING, CALIFORNIA DEMOLITION PLAN	
SHEET	NO.
C2.0	10/2024
DATE	PROJ. NO.
10/28/24	016216.100

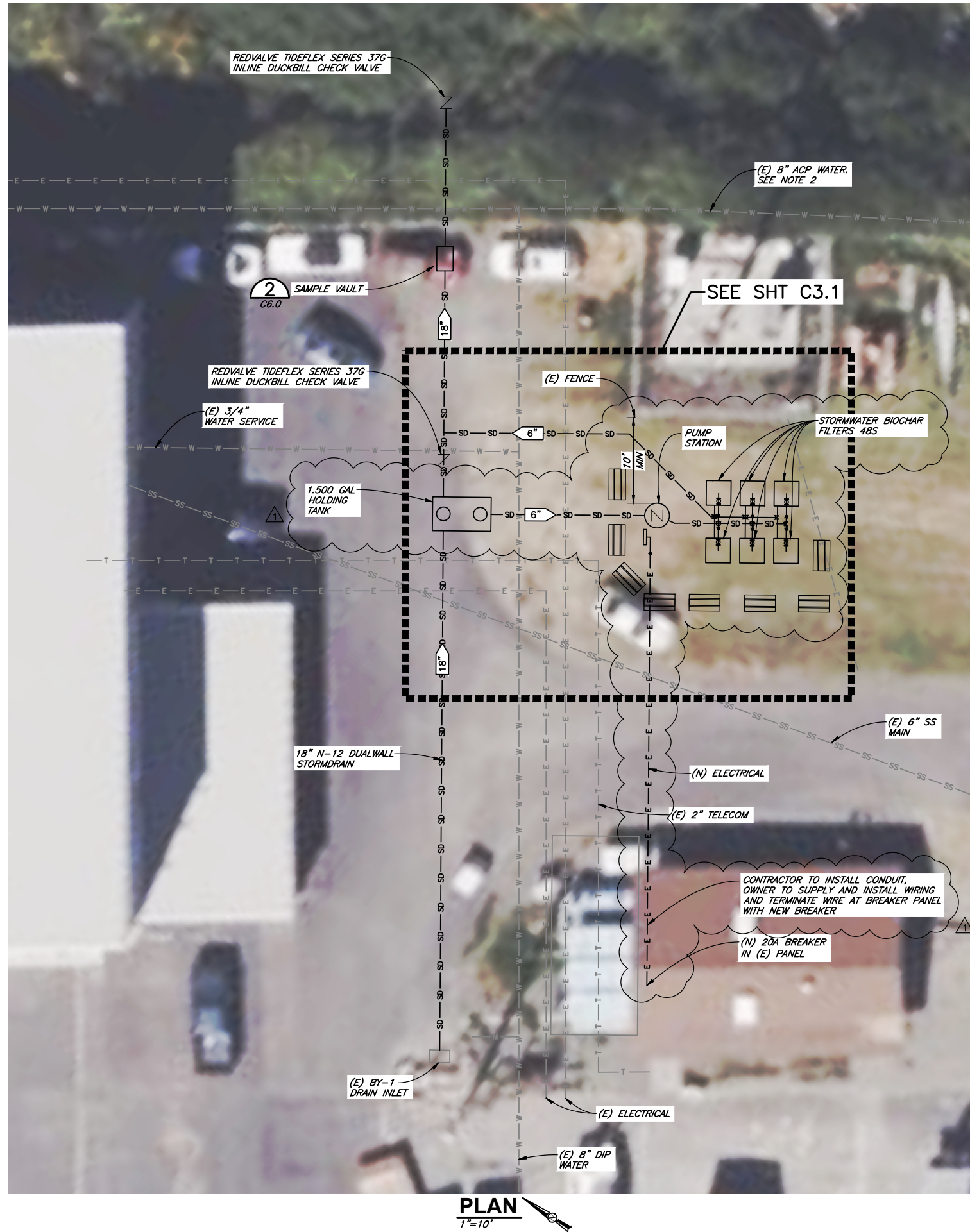

NOTES:

1. CONTRACTOR TO UTILITY LOCATE ALL UNDERGROUND UTILITIES PRIOR TO STARTING WORK SHOWN.
2. EXISTING WATER LINE CONTAINS ASBESTOS MATERIALS. CONTRACTOR SHALL TAKE ALL NECESSARY PRECAUTIONS WHEN EXPOSING PIPING.

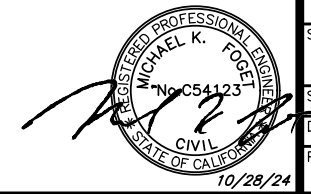

VERIFY SCALES BAR IS ONE INCH ON ORIGINAL DRAWING IF NOT ONE INCH ON THIS SHEET, VERIFY SCALES ACCORDINGLY	
812 W. WABASH AVE. EUREKA, CA 95501 WWW.SHA-8885 707-441-8885	
NO.	REVISION
1	REVISION 1
DATE	BY
05/28/2026	MKF
DSGN JG DR CDN/JWF CHK CRS APVD	
HBHRCD FIELDS LANDING BOAT YARD STORMWATER TREATMENT SYSTEM FIELDS LANDING, CALIFORNIA SITE PLAN AND YARD PIPING	
SHEET	C3.0
SEQ	
DATE	10/2024
PROJ. NO.	016216.100
	10/28/24

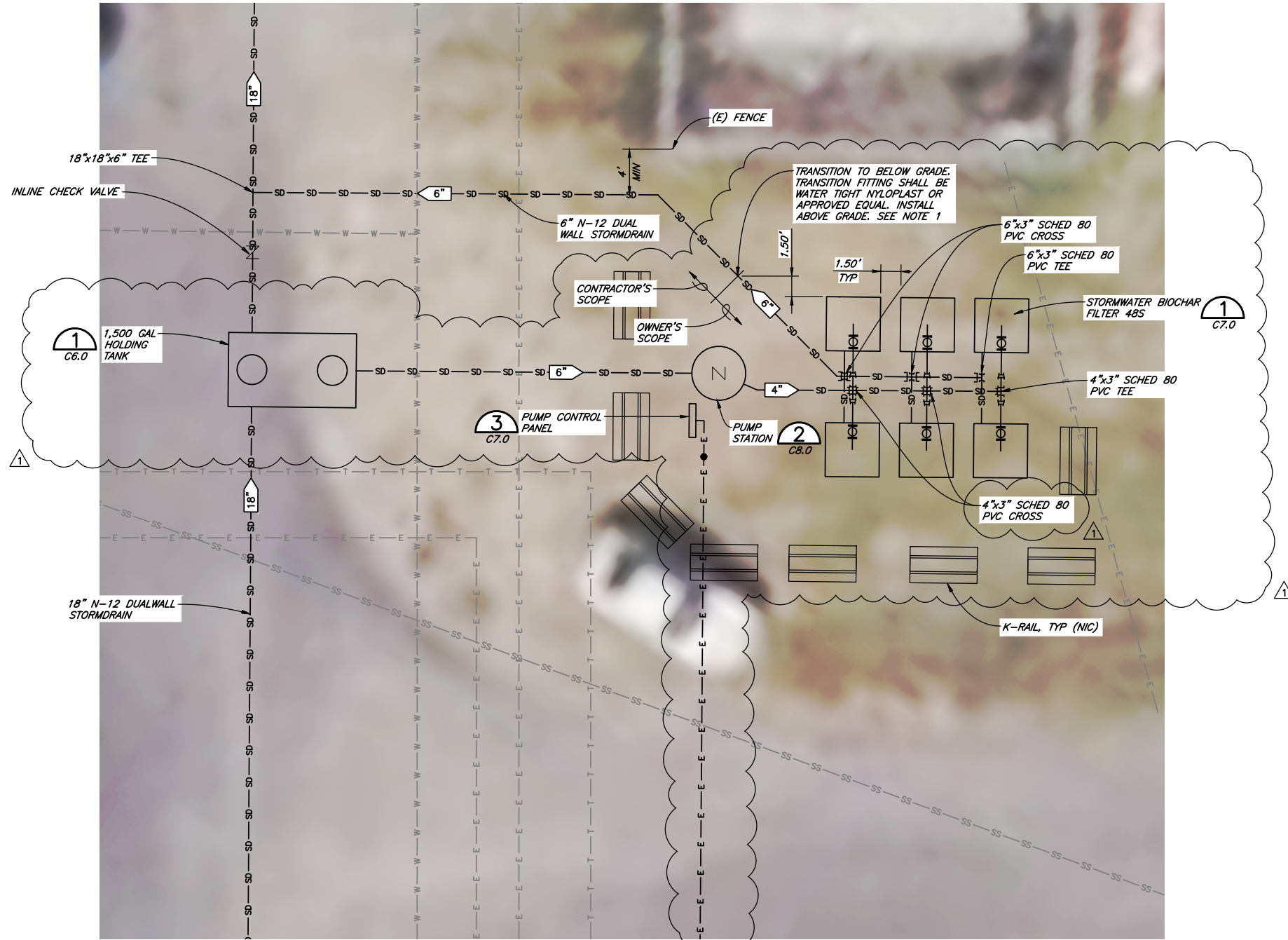

PLAN
 1"=5'

NOTES:

1. CONTRACTOR'S RESPONSIBILITY ENDS AT THE NYLAST TRANSITION FITTING. THE OWNER WILL SUPPLY AND INSTALL ALL ABOVE GROUND PIPING, VALVING, AND FILTERS.
2. EXPOSED PVC TO BE COATED OR TAPED. REFER TO G3.0 FOR SPECIFICATIONS.



VERIFY SCALES BAR IS ONE INCH ON ORIGINAL DRAWING IF NOT ONE INCH ON THIS SHEET, ADJUST SCALES ACCORDINGLY	
812 W. WABASH AVE. EUREKA, CA 95501 WWW.SHA-8865 707-441-8865	
NO.	1
DATE	05/28/2026
REVISION	REVISION 1
BY	MKF
DR	JG
CHK	CDN/JWF
APVD	CFS
HBHRCD FIELDS LANDING BOAT YARD STORMWATER TREATMENT SYSTEM FIELDS LANDING, CALIFORNIA ENLARGED SITE PLAN	
SHEET	C3.1
SEQ	
DATE	10/2024
PROJ. NO.	016216.100

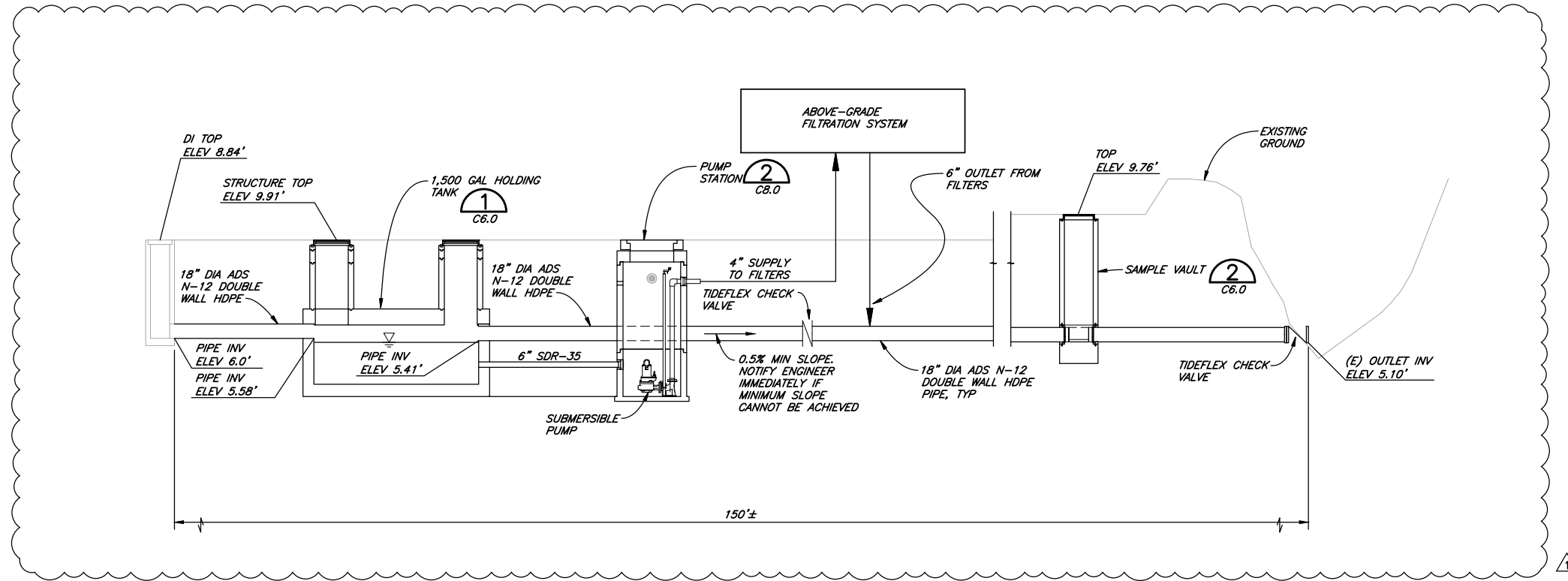

NOTE:
 1. ALL ELEVATIONS SHOWN WITH RESPECT TO THE NORTH AMERICAN VERTICAL DATUM OF 1988 (NAVD88).

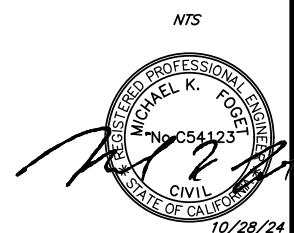

VERIFY SCALES BAR IS ONE INCH ON ORIGINAL DRAWING IF NOT ONE INCH ON THIS SHEET ADJUST SCALES ACCORDINGLY	
812 W. WABASH AVE. EUREKA, CA 95501 WWW.SFH-CR.COM 707-441-8865	
NO.	REVISION
1	REVISION 1
DATE	BY
05/28/2026	MMF
DSGN JG DR CDN/JWF CHK CRS APVD	
HBHRCD FIELDS LANDING BOAT YARD STORMWATER TREATMENT SYSTEM FIELDS LANDING, CALIFORNIA HYDRAULIC PROFILE	
SHEET	C4.0
SEQ	
DATE	10/2024
PROJ. NO.	016216.100

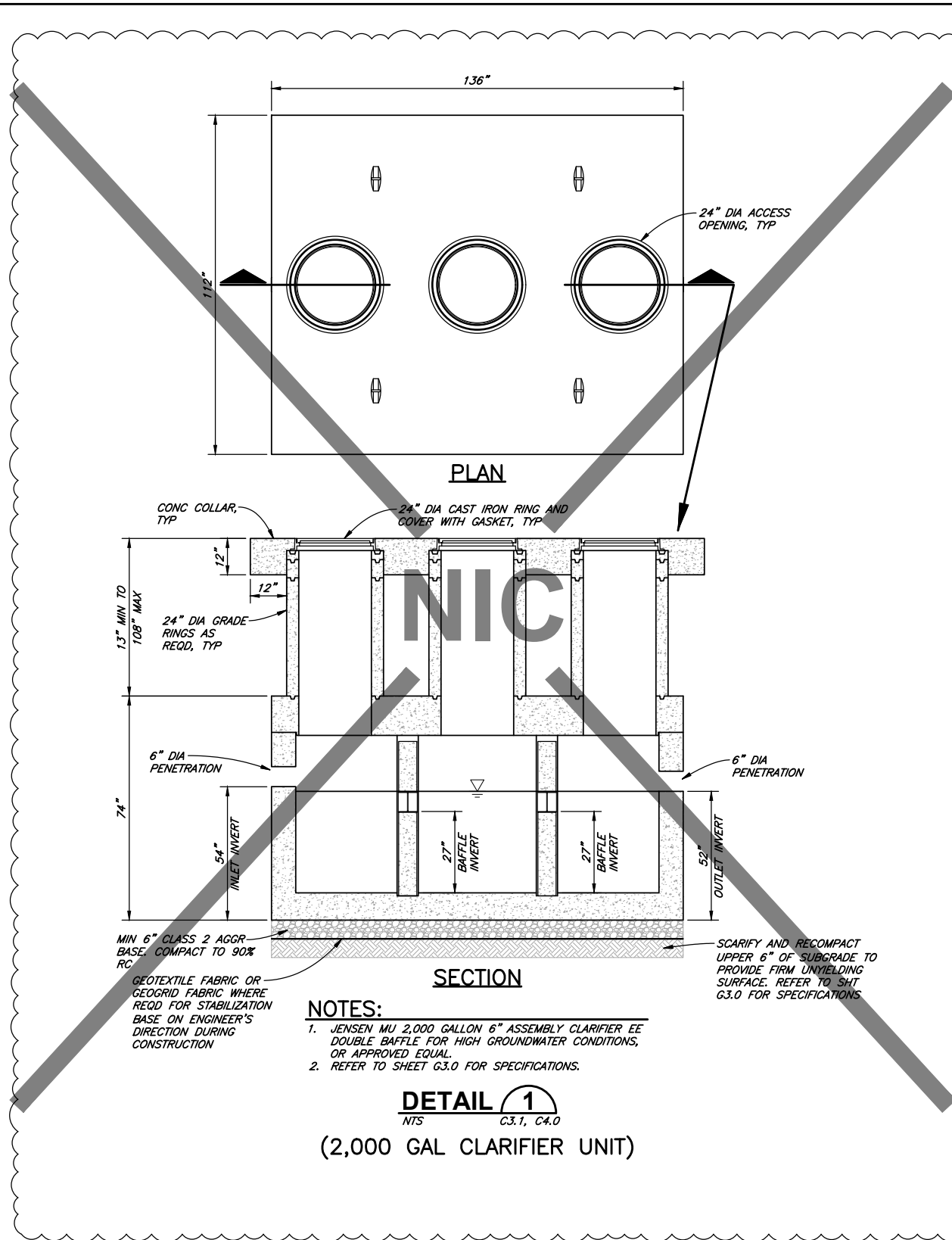

NOTES:
 1. JENSEN MU 2,000 GALLON 6" ASSEMBLY CLARIFIER EE DOUBLE BAFFLE FOR HIGH GROUNDWATER CONDITIONS, OR APPROVED EQUAL.
 2. REFER TO SHEET G3.0 FOR SPECIFICATIONS.

DETAIL 1
 NTS C3.1, C4.0
 (2,000 GAL CLARIFIER UNIT)

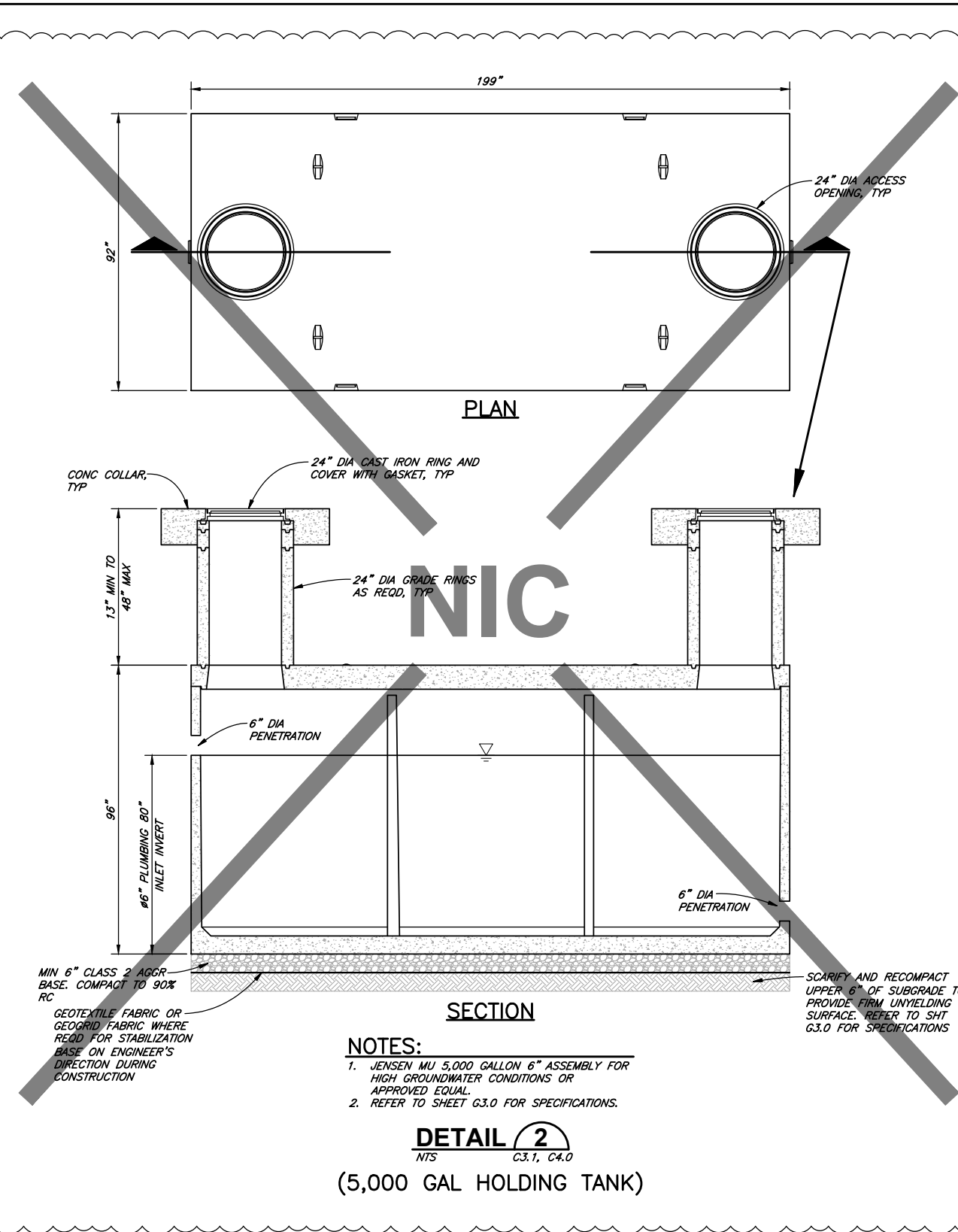

NOTES:
 1. JENSEN MU 5,000 GALLON 6" ASSEMBLY FOR HIGH GROUNDWATER CONDITIONS OR APPROVED EQUAL.
 2. REFER TO SHEET G3.0 FOR SPECIFICATIONS.

DETAIL 2
 NTS C3.1, C4.0
 (5,000 GAL HOLDING TANK)



VERIFY SCALES BAR IS ONE INCH ON ORIGINAL DRAWING IF NOT ONE INCH ON THIS SHEET ADJUST SCALES ACCORDINGLY	
812 W. WABASH AVE. EUREKA, CA 95501 WWW.S&W-ENR.COM 707-441-8865	
NO.	1
DATE	05/28/2026
REVISION	REVISION 1
BY	MAK
DSGN	JG
DR	CDN/JWF
CHK	CRS
APVD	
HBHRCD FIELDS LANDING BOAT YARD STORMWATER TREATMENT SYSTEM FIELDS LANDING, CALIFORNIA	
TANK DETAILS	
SHEET	C5.0
SEQ	
DATE	10/2024
PROJ. NO.	016216.100
10/28/24	

SAVED: 5/28/2026 11:10 AM JFOSTER, PLOTTED: 5/28/2026 12:54 PM JOHN FOSTER
 F:\Eureka\2016\016216-HBHRCD-FL-IGP\Draws\016216-TANKS.dwg

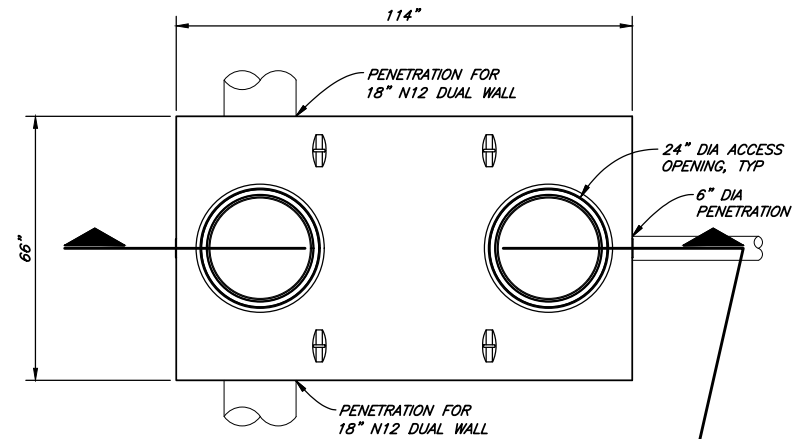

PLAN

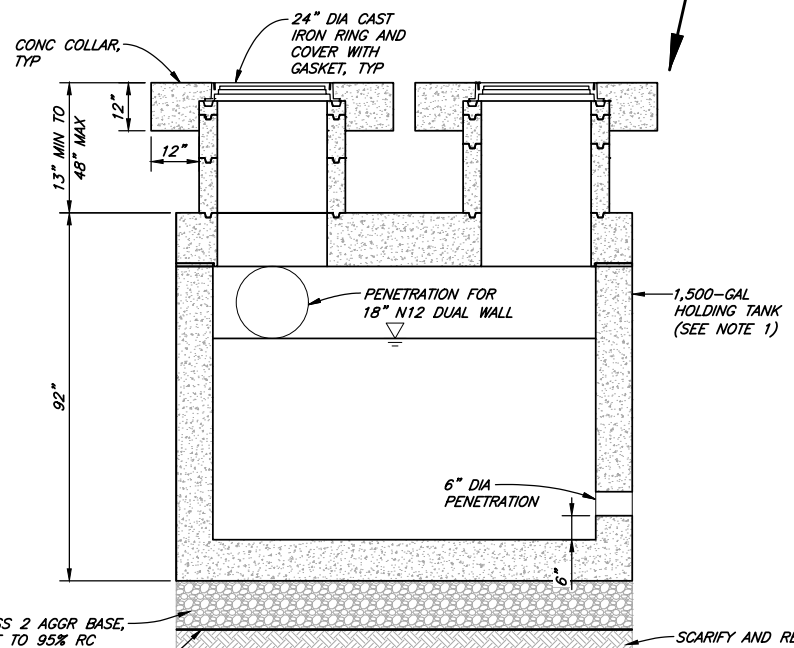

SECTION

12" CLASS 2 AGGR BASE,
 COMPACT TO 95% RC
 GEOTEXTILE FABRIC OR
 GEOGRID FABRIC WHERE
 REQD FOR STABILIZATION
 BASE ON ENGINEER'S
 DIRECTION DURING
 CONSTRUCTION

NOTES:

- JENSEN MU 1,500 GALLON TRAFFIC RATED ASSEMBLY FOR HIGH GROUNDWATER CONDITIONS OR APPROVED EQUAL.
- REFER TO SHEET G3.0 FOR SPECIFICATIONS.

DETAIL 1
NTS C3.1, C4.0

(1,500 GAL HOLDING TANK)

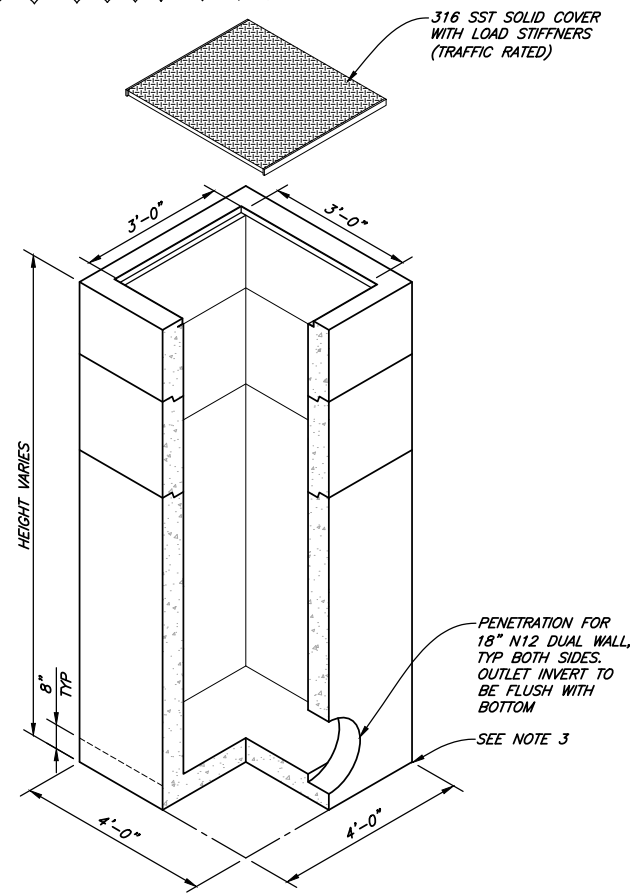

NOTES:

- OLD CASTLE DI-3636, TRAFFIC RATED, OR APPROVED EQUAL.
- PIPING CONNECTIONS SHALL INCLUDE PIPE MANUFACTURER'S RECOMMENDED WATER-PROOF GASKET OR SEAL.
- 12" THICK AGGREGATE BASE, 95% RELATIVE COMPACTION.

DETAIL 2
NTS C3.0, C4.0

(SAMPLE VAULT)



VERIFY SCALES BAR IS ONE INCH ON ORIGINAL DRAWING IF NOT ONE INCH ON THIS SHEET ADJUST SCALES ACCORDINGLY	
812 W. WABASH AVE. EUREKA, CA 95501 WWW.SFH.COM 707-441-8865	
NO.	DATE
1	05/28/2026
REVISION	BY
REVISION 1	MKF
DR	JG
CDN/JWF	
CHK	CRS
APVD	APVD
HBHRCD FIELDS LANDING BOAT YARD STORMWATER TREATMENT SYSTEM FIELDS LANDING, CALIFORNIA	
TANK DETAILS	
SHEET	C6.0
SEQ	
DATE	10/2024
PROJ. NO.	016216.100
10/28/24	

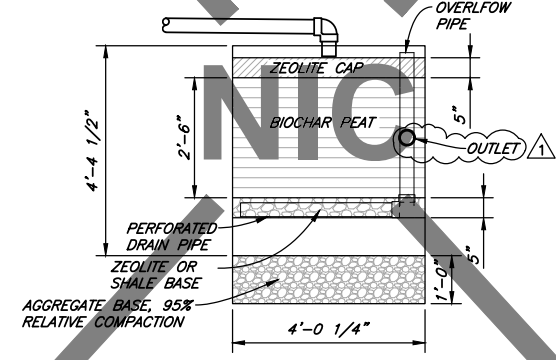
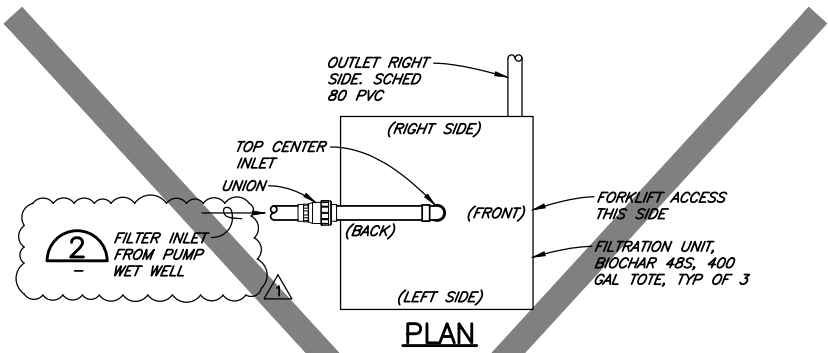

- NOTES:**
- FILTRATION UNITS, FILTER MEDIA, OUTLET PIPING AND APPURTENANCES BY "BIOCHAR STORMWATER FILTRATION SYSTEMS".
 - INSTALL ACCORDING TO MANUFACTURER'S RECOMMENDATIONS.

DETAIL 1
 NTS C3.1
 (FILTER UNIT)

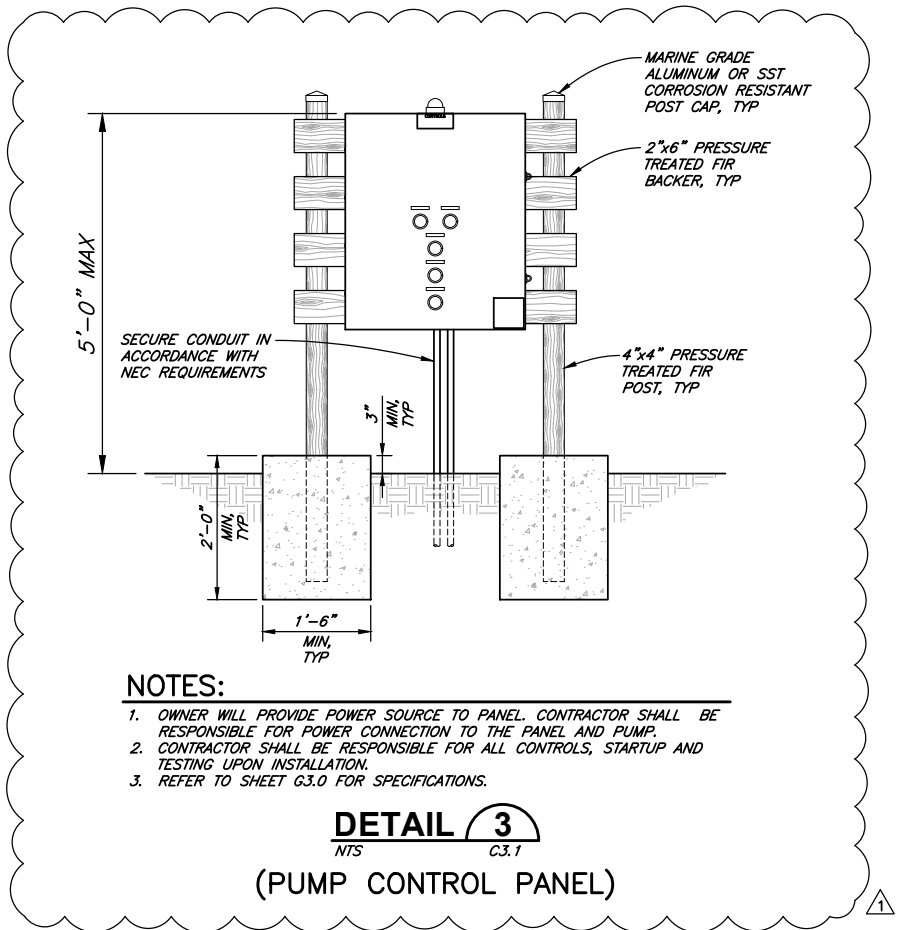
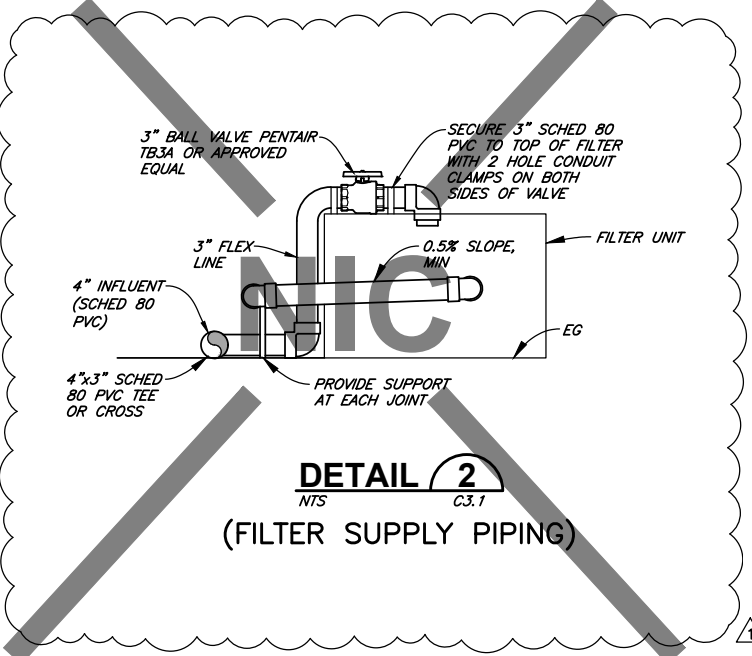

VERIFY SCALES BAR IS ONE INCH ON ORIGINAL DRAWING IF NOT ONE INCH ON THIS SHEET, INDICATE SCALES ACCORDINGLY	
812 W. WABASH AVE. EUREKA, CA 95501 WWW.SFH-SR.COM 707-441-8885	
BY	MAK
REVISION	1
DATE	05/28/2026
NO.	1
DESIGN	JG
DR	CDN/JWF
CHK	CRS
APVD	
HBHRCD FIELDS LANDING BOAT YARD STORMWATER TREATMENT SYSTEM FIELDS LANDING, CALIFORNIA	
DETAILS	
SHEET	C7.0
SEQ	
DATE	10/2024
PROJ. NO.	016216.100

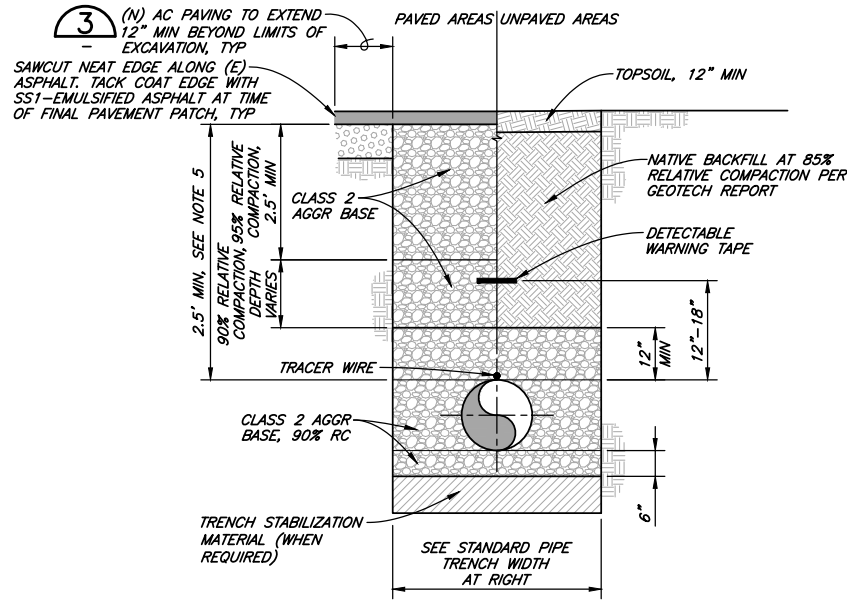

PIPE DIA "D"	MINIMUM "A"	MAXIMUM "A"
<4"	3"	6"
4" TO 6"	6"	12"
6" TO 15"	8"	14"
16" TO 21"	10"	16"
24" TO 30"	12"	18"
33" TO 42"	15"	21"
48" & LARGER	18"	24"

NOTES:

1. WIDER TRENCHES MAY REQUIRE HIGHER STRENGTH PIPE AND/OR SPECIAL BEDDING.
2. DIFFERING TRENCH WIDTHS REQUIRE PRIOR APPROVAL OF ENGINEER.
3. IN MAKING EXCAVATIONS FOR THIS PROJECT, THE CONTRACTOR SHALL BE FULLY RESPONSIBLE FOR PROVIDING AND INSTALLING ADEQUATE SHEETING, SHORING AND BRACING AS MAY BE NECESSARY AS A PRECAUTION AGAINST SLIDES OR CAVE-INS, AND TO PROTECT ALL EXISTING IMPROVEMENTS OF ANY KIND, EITHER ON PUBLIC OR PRIVATE PROPERTY, FULLY FROM DAMAGE.
4. SATISFACTORY NATIVE BACKFILL MATERIAL USED AS UTILITY TRENCH BACKFILL BELOW UNPAVED AREAS SHALL BE APPROVED BY THE ENGINEER PRIOR TO USE.
5. 2-SACK SLURRY BACKFILL MAY BE USED IN TRENCH WHEN MINIMUM PIPE COVER NOT POSSIBLE, WHEN APPROVED BY OWNER'S REPRESENTATIVE. CONTRACTOR MUST SECURE PIPE TO PREVENT FLOATATION.
6. DETECTABLE WARNING TAPE SHALL BE BRIGHT COLORED, CONTINUOUSLY PRINTED, MINIMUM 6" WIDE BY 4 MIL THICK, MANUFACTURED FOR DIRECT BURIAL.
7. DETECTABLE WARNING TAPE NOT REQUIRED FOR IRRIGATION LINES.
8. GRAVEL ROADS SHALL USE PAVED AREA TRENCH SECTION BUT WITH AGGREGATE BASE TO SURFACE, UNLESS NOTED OTHERWISE.
9. MAINTAIN A MINIMUM OF 2'-0" SEPARATION WHERE PIPES ARE INSTALLED WITHIN THE SAME TRENCH.

DETAIL 1
NTS
(TYPICAL TRENCH)

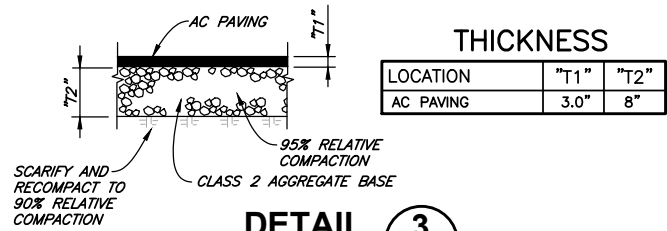

THICKNESS

LOCATION	"T1"	"T2"
AC PAVING	3.0"	8"

DETAIL 3
NTS
(TYP PAVING STRUCTURAL SECTION)

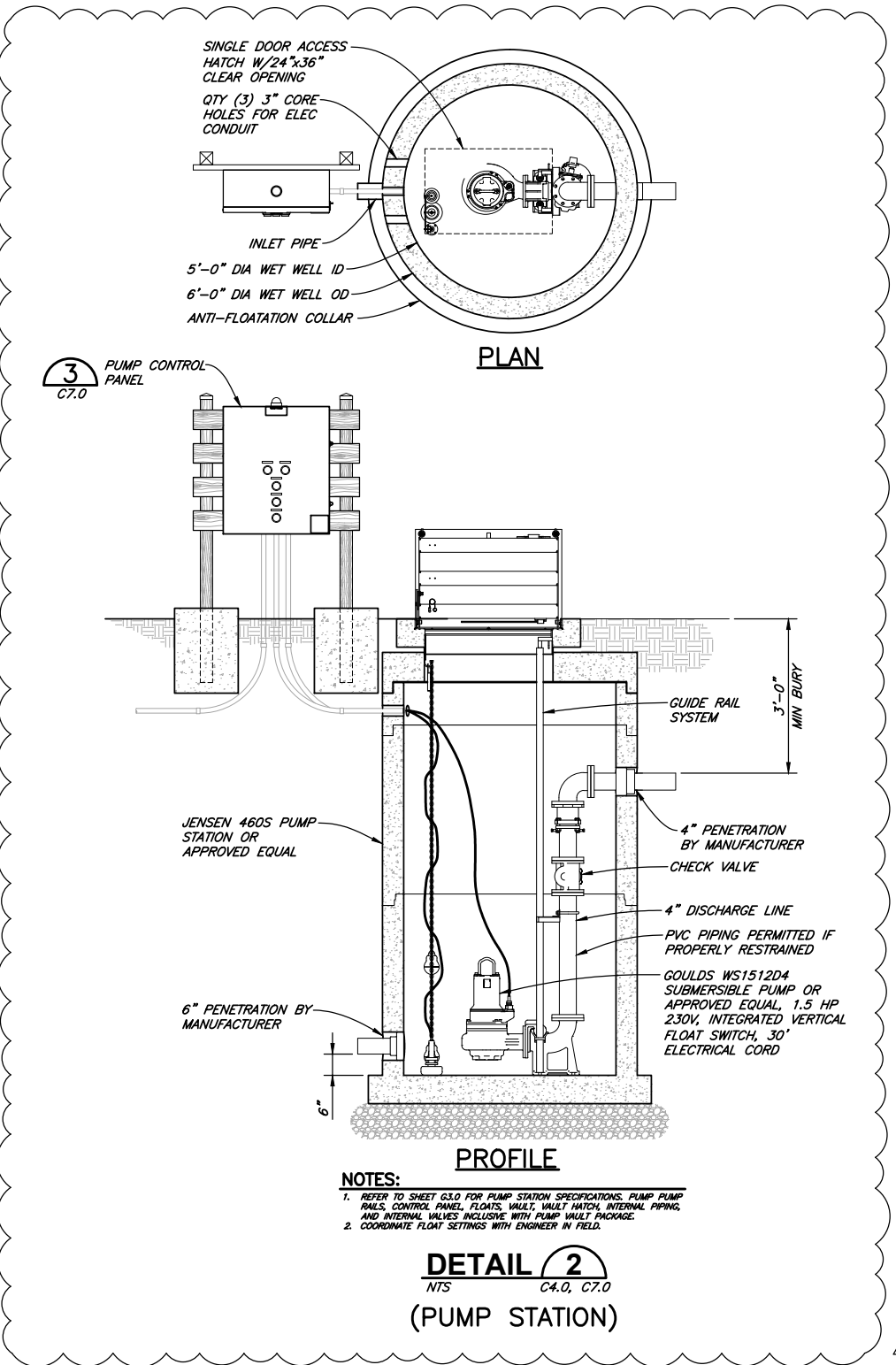

- NOTES:**
1. REFER TO SHEET G3.0 FOR PUMP STATION SPECIFICATIONS. PUMP, PUMP RAIS, CONTROL PANEL, FLOATS, VAULT, VAULT HATCH, INTERNAL PIPING, AND INTERNAL VALVES INCLUSIVE WITH PUMP VAULT PACKAGE.
 2. COORDINATE FLOAT SETTINGS WITH ENGINEER IN FIELD.

DETAIL 2
NTS
(PUMP STATION)

SAVEN: 5/28/2026 11:23 AM JFOSTER, PLOTTED: 5/28/2026 12:54 PM JOHN FOSTER
 F:\Eureka\2016\016216-HBHRCD-FL-IGP\Draws\016216-100-DTL.dwg



VERIFY SCALES
 BAR IS ONE INCH ON ORIGINAL DRAWING
 IF NOT ONE INCH ON THIS SHEET, ADJUST SCALES ACCORDINGLY

812 W. WABASH AVE.
 EUREKA, CA 95501
 WWW.SFH-CR.COM
 707-441-8885

DR	JG	CDN/JWF
CHK	CFS	
APVD		

HBRCD
 FIELDS LANDING BOAT YARD STORMWATER TREATMENT SYSTEM
 FIELDS LANDING, CALIFORNIA

DETAILS

SHEET	C8.0
SEQ	
DATE	10/2024
PROJ. NO.	016216.100

REVISION 1
 DATE 05/28/2026
 MKF BY

(CONTRACT AGREEMENT PACKAGE)

(Attach completed Contractor's "Certificate of Insurance" to this page)

CERTIFICATE OF INSURANCE					ISSUE DATE (MM/DD/YY)	
THE HUMBOLDT BAY HARBOR, RECREATION & CONSERVATION DISTRICT, CALIFORNIA						
PRODUCER		THIS CERTIFICATE OF INSURANCE IS NOT AN INSURANCE POLICY AND DOES NOT AMEND, EXTEND OR ALTER THE COVERAGE AFFORDED BY THE POLICIES BELOW.				
		INSURERS AFFORDING COVERAGE:			BEST'S RATING	
		INSURER A: _____				
INSURED		INSURER B: _____				
		INSURER C: _____				
		INSURER D: _____				
		INSURER E: _____				
THIS IS TO CERTIFY THAT THE POLICIES OF INSURANCE LISTED BELOW HAVE BEEN ISSUED TO THE INSURED NAMED ABOVE FOR THE POLICY PERIOD INDICATED. NOTWITHSTANDING ANY REQUIREMENT, TERM OR CONDITION OF ANY CONTRACT OR OTHER DOCUMENT WITH RESPECT TO WHICH THIS CERTIFICATE MAY BE ISSUED OR MAY PERTAIN, THE INSURANCE AFFORDED BY THE POLICIES DESCRIBED HEREIN IS SUBJECT TO ALL THE TERMS, EXCLUSIONS AND CONDITIONS OF SUCH POLICIES. AGGREGATE LIMITS SHOWN MAY HAVE BEEN REDUCED BY PAID CLAIMS.						
INSR LTR	TYPE OF INSURANCE	POLICY NUMBER	POLICY EFFECTIVE DATE (MM/DD/YY)	POLICY EXP. DATE (MM/DD/YY)	ALL LIMITS IN THOUSANDS	
	GENERAL LIABILITY <input type="checkbox"/> COMMERCIAL GENERAL LIABILITY <input type="checkbox"/> CLAIMS MADE <input type="checkbox"/> OCCURRENCE <input type="checkbox"/> OWNER'S & CONTRACTOR'S PROT. <input type="checkbox"/> OTHER				EACH OCCURRENCE	\$
					DAMAGE TO RENTED PREMISES (Ea occurrence)	\$
					MED. EXP. (Any one person)	\$
					PERSONAL & ADV INJURY	\$
					GENERAL AGGREGATE	\$
					PRODUCTS COMP/OP AGG.	\$
	AUTOMOBILE LIABILITY <input type="checkbox"/> ANY AUTO <input type="checkbox"/> ALL OWNED AUTOS <input type="checkbox"/> SCHEDULED AUTOS <input type="checkbox"/> HIRED AUTOS <input type="checkbox"/> NON-OWNED AUTOS <input type="checkbox"/> GARAGE LIABILITY				COMBINED SINGLE LIMIT (Ea accident)	\$
					BODILY INJURY (Per person)	\$
					BODILY INJURY (Per accident)	\$
					PROPERTY DAMAGE	\$
	EXCESS/UMBRELLA LIABILITY <input type="checkbox"/> CLAIMS MADE <input type="checkbox"/> OCCURRENCE <input type="checkbox"/> DEDUCTIBLE <input type="checkbox"/> RETENTION				EACH OCCURRENCE	\$
					AGGREGATE	\$
	WORKERS' COMPENSATION AND EMPLOYER'S LIABILITY ANY PROPRIETOR/PARTNER/EXECUTIVE OFFICERS/MEMBER EXCLUDED? If yes, describe under SPECIAL PROVISIONS below.				WC STATUTORY LIMITS	OTHER
					EACH ACCIDENT	
					DISEASE-POLICY LIMIT	
					DISEASE-EACH EMPLOYEE	
	PROPERTY INSURANCE <input type="checkbox"/> COURSE OF CONSTRUCTION				AMOUNT OF INSURANCE	\$
DESCRIPTION OF OPERATIONS/LOCATIONS/VEHICLES/EXCLUSIONS ADDED BY ENDORSEMENT/SPECIAL PROVISIONS						
THE FOLLOWING PROVISIONS APPLY:						
<ol style="list-style-type: none"> 1. None of the above-described policies will be canceled until after 30 days' written notice has been given to the District at the address indicated below. 2. The District, its officials, officers, employees, and volunteers are added as insureds on all liability insurance policies listed above. 3. It is agreed that any insurance or self-insurance maintained by the District will apply in excess of and not contribute with the insurance described above. 4. The District is named a loss payee on the property insurance policy listed above, if any. 5. All rights of subrogation under the property insurance policy listed above have been waived against the District. 6. The workers' compensation insurer named above, if any, agrees to waive all rights of subrogation against the District for injuries to employees of the insured resulting from work for the District or use of the District's premises or facilities. 						
CERTIFICATE HOLDER/ADDITIONAL INSURED The Humboldt Bay Harbor, Recreation & Conservation District, 601 Startare Drive, Eureka, CA 95501				AUTHORIZED REPRESENTATIVE		
				SIGNATURE _____		
				TITLE _____		
				PHONE NO. _____		

Rev. 6/08

(CONTRACT AGREEMENT PACKAGE)

(Attach completed Contractor's "Commercial General Liability Endorsement" to this page.)

INSURER:
POLICY NUMBER:
ENDORSEMENT NUMBER:

ISO FORM CG 20 10 22 85: (MODIFIED)
COMMERCIAL GENERAL LIABILITY

THIS ENDORSEMENT CHANGES THE POLICY, PLEASE READ IT CAREFULLY

**ADDITIONAL INSURED – OWNERS, LESSEES, OR
CONTRACTORS (FORM B)**

THIS ENDORSEMENT MODIFIES INSURANCE PROVIDED UNDER THE FOLLOWING:

COMMERCIAL GENERAL LIABILITY COVERAGE PART.

SCHEDULE

NAME OF ORGANIZATION:

**HUMBOLDT BAY HARBOR, RECREATION & CONSERVATION DISTRICT
601 Startare Drive, Eureka, California 95501**

WHO IS AN INSURED (Section II) is amended to include as an insured the person or organization shown in the Schedule, but only with respect to liability arising out of "your work" for that insured by or for you.

Modifications to ISO form CG 20 10 11 85:

1. The insured scheduled above includes the Insured's officers, officials, employees, and volunteers.
2. This insurance shall be primary as respects the insured shown in the schedule above, or if excess, shall stand in an unbroken chain of coverage excess of the Named Insured's scheduled underlying primary coverage. In either event, any other insurance maintained by the Insured scheduled above shall be in excess of this insurance and shall not be called upon to contribute with it.
3. The insurance afforded by this policy shall not be canceled except after thirty days prior written notice by certified mail return receipt requested has been given to the District.

Signature-Authorized Representative

Address

CG 20 10 11 85 Insurance Services Office, Inc. Form (Modified)

(CONTRACT AGREEMENT PACKAGE)

(Attach completed Contractor's "Workers' Compensation and Employer's Liability Special Endorsement" to this page.)

WORKERS' COMPENSATION AND EMPLOYER'S LIABILITY SPECIAL ENDORSEMENT FOR THE HUMBOLDT BAY HARBOR, RECREATION & CONSERVATION DISTRICT, CALIFORNIA	SUBMIT IN DUPLICATE	
	ENDORSEMENT NO.	ISSUE DATE (MM/DD/YY)
PRODUCER Telephone _____	POLICY INFORMATION: Insurance Company: _____ Policy No.: _____ Policy Period: (from) _____ (to) _____	
NAMED INSURED 	OTHER PROVISIONS 	
	CLAIMS: Underwriter's representative for claims pursuant to this insurance. Name: _____ Address: _____ Telephone: _____	EMPLOYER'S LIABILITY LIMITS \$ _____ (Each Accident) \$ _____ (Disease-Policy Limit) \$ _____ (Disease-Each Employee)
<p>In consideration of the premium charged and notwithstanding any inconsistent statement in the policy to which this endorsement is attached or any endorsement now or hereafter attached thereto, it is agreed as follows:</p> <p>1. CANCELLATION NOTICE. This insurance shall not be canceled, except after thirty (30) days prior written notice by receipted delivery has been given to the District.</p> <p>2. WAIVER OF SUBROGATION. This Insurance Company agrees to waive all rights of subrogation against the District, its officers, officials, employees, and volunteers for losses paid under the terms of this policy which arise from the work performed by the Named Insured for the District.</p> <p>Except as stated above nothing herein shall be held to waive, alter or extend any of the limits, conditions, agreements or exclusions of the _____ policy to which this endorsement is attached.</p>		
ENDORSEMENT HOLDER		
HUMBOLDT BAY HARBOR, RECREATION & CONSERVATION DISTRICT 601 Startare Drive Eureka, California 95501	AUTHORIZED REPRESENTATIVE <input type="checkbox"/> Broker/Agent <input type="checkbox"/> Underwriter <input type="checkbox"/> _____ I, _____ (print/type name), warrant that I have authority to bind the above-mentioned insurance company and by my signature hereon do so bind this company to this endorsement. Signature _____ <i>(original signature required)</i> Telephone: (_____) _____ Date Signed _____	

REV. 1/93

COMMISSIONERS
 1st Division
 Aaron Newman
 2nd Division
 Greg Dale
 3rd Division
 Stephen Kullmann
 4th Division
 Craig Benson
 5th Division
 Jack Norton

Humboldt Bay
Harbor, Recreation and Conservation District
 (707) 443-0801
 P.O. Box 1030
 Eureka, California 95502-1030



STAFF REPORT - HARBOR DISTRICT MEETING

June 11, 2026

TO: Honorable Board President and Harbor District Board Members

FROM: Chris Mikkelsen, Executive Director

DATE: May 21, 2026

TITLE: Consideration of Fiscal Year 2026-2027 Budget and Preliminary Goals for Redwood Marine Terminal I, Redwood Marine Terminal II, and Shelter Cove

STAFF RECOMMENDATION: Staff recommends that the Board direct staff to implement the 2026-2027 Fiscal Year Budget Preparation Schedule and receive a report on the proposed capital expense projects for Redwood Marine Terminals I and II, and Shelter Cove.

SUMMARY: Beginning at the April 9th meeting, staff will present the capital expense projects under consideration for the 2026-2027 fiscal year and the projected costs of each. These items do not include the recurring maintenance and operations costs, which will be presented in the final draft budget brought to the commission for approval in July.

DISCUSSION: Staff recommends utilizing the following schedule to review goals, revenue, and expenditures by programmatic activity. These meetings will double as strategy sessions, which will be used by the Board, Executive Director, and District Staff to clearly understand where each activity is financially and what we can reasonably accomplish within our financial means. Staff will work with the Budget Subcommittee to prepare the budget and bring the complete budget to the Board for approval.

Date	Meeting Type	Purpose
April 9	Regular	A) Preliminary Goals, Income, and Expenditures: 1. Woodley Island Marina 2. Fields Landing Boat Yard 3. Dredging
May 14	Regular	A) Preliminary Goals, Income, and Expenditures: 1. Redwood Marine Terminal I 2. Redwood Marine Terminal II 3. Shelter Cove
June 11	Regular	A) Preliminary Goals, Income, and Expenditures: 1. Port Operations 2. Conservation and Recreation Programs 3. Administrative Services 4. General Operating and Staffing 5. Follow-up discussion from previous budget meeting topics B) Adopt Preliminary Budget
July 9	Regular	Budget Adoption and Transmission to the County Board of Supervisors



COMMISSIONERS

1st Division

Aaron Newman

2nd Division

Greg Dale

3rd Division

Stephen Kullmann

4th Division

Craig Benson

5th Division

Jack Norton

Humboldt Bay
Harbor, Recreation and Conservation District
 (707)443-0801
 P.O. Box 1030
 Eureka, California 95502-1030

STAFF REPORT
HARBOR DISTRICT MEETING
June 11, 2026

TO: Honorable Board President and Harbor District Board Members

FROM: Chris Mikkelsen, Executive Director

DATE: June 5, 2026

TITLE: Preliminary Budget Adoption for Fiscal Year 2026-27

STAFF RECOMMENDATION: Consider adoption of the 2026-27 Preliminary Budget and set a hearing date for the adoption of the 2026-27 Final Budget.

SUMMARY: The Budget is prepared annually under the direction of the Executive Director. In accordance with CA Harbors and Navigation Code Section 6093, on or before June 15, the District Board shall estimate and determine the amount of money required by the Harbor District and shall adopt a preliminary budget. Per Section 6093.3, the final budget shall be reported to the Board of Supervisors not later than August 1st.

DISCUSSION: The Preliminary budget provides an estimate of what will be included in the final budget. If the Board adopts the preliminary budget, staff will work with the District Treasurer to develop a detailed categorical monthly budget by class and with a cash flow analysis of the income and expenditures, as well as an update of the reserve and contractual fund balances. Should there be specific changes to the Preliminary Budget that the Board would like to consider, staff recommends the Board adopt the Preliminary Budget and direct staff to work with the Budget Advisory Committee and District Treasurer on such. It is essential to note that District Staff continues to have a substantial workload and will continue to refine, in detail, a final budget recommended for adoption.

The following are some highlights and assumptions:

1. Expenditures in FY 2025-2026 were within or below budgeted amounts, although some projects had to be deferred.
2. The preliminary budget will balance if we defer proposed capital projects.
3. Rental income on the District’s Samoa Peninsula is down due to the loss of Nordic Aquafarms and the holding of leasable space for their intended activities.
4. Increased legal expenses are projected to continue in support of the proposed Heavy Lift Marine Terminal development.

5. Dredging of Woodley Island Marina occurred in operational years 2024 and 2025; however, no dredging is planned for FY 2026-2027 until there is clarity on our pending FEMA DR4683 application for Federal Assistance. While we have been found eligible, challenges persist within FEMA, which have extensively drawn out this process.
6. An approximately \$6 million contract was executed with Caltrans for the Spartina Eradication Project, which began in June 2023. A portion of these funds are budgeted in the current fiscal year as we move into the fourth year of the project.
7. Approximately \$11 million in grant funds have been awarded from the California Energy Commission for the Heavy Lift Marine Terminal; these funds are budgeted and expended over three years, beginning in the 2024-2025 fiscal year.
8. Approximately \$18.25 million in grant funds have been awarded from the California Energy Commission, to which a grant agreement was just executed. Staff is working on an expenditure plan beginning in FY26-27, with funds benefiting the Heavy Lift Marine Terminal Project.
9. The Fields Landing Boat Yard industrial pretreatment is now planned for the coming fiscal year, with an RFP to be issued in the coming few weeks. To preserve and work within the District's limited funds, qualified staff will self-perform a portion of the intended work, with the remainder to be contracted to a qualified local contractor.
10. The District will continue to evaluate the staffing needs as we continue to work to grow and transition our port.
11. Staff will hold up to two study sessions with the Budget Subcommittee (dates to be confirmed) to finalize the District's Final Fiscal Year 2026-27 Budget.

ATTACHMENTS:

- A. Preliminary Budget

Budget Name Preliminary Fiscal Year 2026 27 Budget

Company Humboldt Bay Harbor, Recreation & Conservation District

Budgeting Period FY 2027 (Jul2026 - Jun2027)

Type Profit & Loss Budget

Account Number	Accounts	Account Type	Total Budget	\$ 46,204.00	\$ 46,235.00	\$ 46,266.00	\$ 46,296.00	\$ 46,327.00	\$ 46,357.00	\$ 46,388.00	\$ 46,419.00	\$ 46,447.00	\$ 46,478.00	\$ 46,508.00	\$ 46,539.00
	Billable Expense Income	Income	\$ -												
	Billable Expense Income (557)	Income	\$ -												
	Billable Expense Income (559)	Income	\$ -												
	Billable Expense Income-1	Income	\$ -												
	Donations	Income	\$ -												
46519	Donations:Donations - Lighthouse	Income	\$ 6.00	\$ -	\$ -	\$ -	\$ -	\$ -	\$ -	\$ 6.00	\$ -	\$ -	\$ -	\$ -	\$ -
45709	Donations:Donations - Sea Scouts	Income	\$ -												
	Dredging Revenue	Income	\$ -												
41318	Dredging Revenue:Dredging Surcharge - T	Income	\$ 209,458.00	\$ 18,450.00	\$ 18,260.00	\$ 18,027.00	\$ 17,763.00	\$ 17,553.00	\$ 17,604.00	\$ 17,708.00	\$ 17,257.00	\$ 16,761.00	\$ 16,338.00	\$ 16,194.00	\$ 17,543.00
	Fees	Income	\$ -												
40618	Fees:Boat Launch Fees - T	Income	\$ -												
45608	Fees:Chevron - Ports O&M - T	Income	\$ 28,604.00	\$ 2,314.00	\$ 2,507.00	\$ 2,716.00	\$ 2,248.00	\$ 2,435.00	\$ 2,638.00	\$ 2,164.00	\$ 2,344.00	\$ 2,539.00	\$ 2,057.00	\$ 2,228.00	\$ 2,414.00
40609	Fees:Haul Out Fees - T	Income	\$ -												
41819	Fees:Late Charges/Interest - NT	Income	\$ 11,420.00	\$ 905.00	\$ 968.00	\$ 996.00	\$ 962.00	\$ 897.00	\$ 920.00	\$ 934.00	\$ 1,006.00	\$ 959.00	\$ 961.00	\$ 964.00	\$ 948.00
41818	Fees:Late Charges/Interest - T	Income	\$ 53,826.00	\$ 4,553.00	\$ 4,564.00	\$ 4,543.00	\$ 4,469.00	\$ 4,475.00	\$ 4,485.00	\$ 4,504.00	\$ 4,469.00	\$ 4,397.00	\$ 4,423.00	\$ 4,452.00	\$ 4,492.00
41308	Fees:Moorage - T	Income	\$ -												
40108	Fees:PERMITS-T	Income	\$ 6,646.00	\$ 466.00	\$ 471.00	\$ 489.00	\$ 517.00	\$ 499.00	\$ 520.00	\$ 563.00	\$ 588.00	\$ 637.00	\$ 648.00	\$ 702.00	\$ 546.00
40808	Fees:Pilotage Services - T	Income	\$ 2,933.00	\$ 262.00	\$ 284.00	\$ 230.00	\$ 250.00	\$ 220.00	\$ 238.00	\$ 258.00	\$ 220.00	\$ 238.00	\$ 258.00	\$ 228.00	\$ 247.00
41308.1	Fees:Poundage - T	Income	\$ 16.00	\$ 3.00	\$ 3.00	\$ 1.00	\$ 1.00	\$ 1.00	\$ 1.00	\$ 1.00	\$ 1.00	\$ 1.00	\$ 1.00	\$ 1.00	\$ 1.00
40509	Fees:Travel Lift Fees - T	Income	\$ -												
	Float Replacement Account	Income	\$ -												
41418	Float Replacement Account:Float Replacement	Income	\$ 66,014.00	\$ 5,816.00	\$ 5,755.00	\$ 5,680.00	\$ 5,595.00	\$ 5,528.00	\$ 5,549.00	\$ 5,588.00	\$ 5,442.00	\$ 5,282.00	\$ 5,146.00	\$ 5,104.00	\$ 5,529.00
	Grant Revenue	Income	\$ -												
45208.3	Grant Revenue:Conservation Grants	Income	\$ -												
	Grant Revenue:Conservation Grants:Conservation Grants, Gov't - T	Income	\$ 77,777.00	\$ 10,248.00	\$ 10,624.00	\$ 11,509.00	\$ 3,947.00	\$ 3,892.00	\$ 4,216.00	\$ 4,568.00	\$ 4,872.00	\$ 5,278.00	\$ 5,718.00	\$ 6,194.00	\$ 6,711.00
	Grant Revenue:Harbor Grants	Income	\$ -												
45208.1	Grant Revenue:Harbor Grants:Harbor Grants, Gov't - T	Income	\$ 4,172,614.00	\$ 385,610.00	\$ 417,744.00	\$ 452,556.00	\$ 459,426.00	\$ 354,561.00	\$ 333,041.00	\$ 258,867.00	\$ 260,685.00	\$ 276,465.00	\$ 299,504.00	\$ 323,930.00	\$ 350,225.00
45208	Grant Revenue:Harbor Grants:Harbor Grants, Other - T	Income	\$ 170,731.00	\$ 9,649.00	\$ 10,453.00	\$ 11,324.00	\$ 12,268.00	\$ 13,290.00	\$ 14,398.00	\$ 15,597.00	\$ 16,897.00	\$ 16,568.00	\$ 17,585.00	\$ 18,884.00	\$ 13,818.00
	Grant Revenue:Recreation Grants	Income	\$ -												
45208.2	Grant Revenue:Recreation Grants:Recreation Grants, Gov't - T	Income	\$ 13,655.00	\$ 2,366.00	\$ 2,563.00	\$ 593.00	\$ 642.00	\$ 696.00	\$ 754.00	\$ 817.00	\$ 885.00	\$ 958.00	\$ 1,038.00	\$ 1,125.00	\$ 1,218.00
	Harbor Surcharge	Income	\$ -												
40908	Harbor Surcharge:Harbor Improvement Surcharge-T	Income	\$ 128,643.00	\$ 11,411.00	\$ 10,941.00	\$ 11,094.00	\$ 11,619.00	\$ 11,057.00	\$ 10,360.00	\$ 10,812.00	\$ 9,984.00	\$ 10,675.00	\$ 9,942.00	\$ 9,959.00	\$ 10,789.00
	Interest Revenue	Income	\$ -												
47009	Interest Revenue:Gain (Loss) on Investments - N	Income	\$ -												
47008	Interest Revenue:Gain (Loss) on Investments - T	Income	\$ -												
43109	Interest Revenue:Interest Income - NT	Income	\$ 63,036.00	\$ 3,841.00	\$ 4,111.00	\$ 4,403.00	\$ 4,720.00	\$ 5,063.00	\$ 5,435.00	\$ 5,456.00	\$ 5,420.00	\$ 5,871.00	\$ 5,762.00	\$ 6,242.00	\$ 6,712.00
43108	Interest Revenue:Interest Income - T	Income	\$ 11,528.00	\$ 993.00	\$ 976.00	\$ 965.00	\$ 984.00	\$ 1,009.00	\$ 1,003.00	\$ 954.00	\$ 915.00	\$ 945.00	\$ 909.00	\$ 917.00	\$ 958.00
43309	Interest Revenue:Interest On Del Accts - NT	Income	\$ -												
43318	Interest Revenue:Interest On Del Accts - T	Income	\$ 510.00	\$ 47.00	\$ 50.00	\$ 54.00	\$ 58.00	\$ 62.00	\$ 26.00	\$ 29.00	\$ 31.00	\$ 34.00	\$ 36.00	\$ 40.00	\$ 43.00
	Markup	Income	\$ -												
	Other Revenue	Income	\$ -												
45909	Other Revenue:Other Revenue - NT	Income	\$ 390,535.00	\$ 26,572.00	\$ 28,783.00	\$ 29,295.00	\$ 31,122.00	\$ 32,595.00	\$ 35,123.00	\$ 36,280.00	\$ 37,088.00	\$ 36,387.00	\$ 34,021.00	\$ 32,810.00	\$ 30,459.00
45912	Other Revenue:Other Revenue - OSW	Income	\$ 792,868.00	\$ 46,327.00	\$ 50,188.00	\$ 54,370.00	\$ 58,901.00	\$ 63,809.00	\$ 69,127.00	\$ 74,887.00	\$ 81,128.00	\$ 87,888.00	\$ 82,629.00	\$ 59,335.00	\$ 64,279.00
45911	Other Revenue:Other Revenue - Spartina	Income	\$ 705,033.00	\$ 60,323.00	\$ 65,350.00	\$ 59,464.00	\$ 62,875.00	\$ 65,783.00	\$ 71,193.00	\$ 53,998.00	\$ 47,587.00	\$ 51,389.00	\$ 52,554.00	\$ 54,968.00	\$ 59,549.00
45908	Other Revenue:Other Revenue - T	Income	\$ 39.00	\$ 3.00	\$ 3.00	\$ 3.00	\$ 3.00	\$ 3.00	\$ 3.00	\$ 3.00	\$ 3.00	\$ 4.00	\$ 4.00	\$ 4.00	\$ 3.00
46008	Other Revenue:Recovery of Bad Debt - T	Income	\$ -												
47019	Other Revenue:Returned Check Charges	Income	\$ -												
	Rent Income	Income	\$ -												
40519	Rent Income:Equipment Rent - NT	Income	\$ 1,523.00	\$ 124.00	\$ 111.00	\$ 120.00	\$ 130.00	\$ 141.00	\$ 137.00	\$ 148.00	\$ 143.00	\$ 105.00	\$ 114.00	\$ 123.00	\$ 127.00
40518	Rent Income:Equipment Rent - T	Income	\$ 5,493.00	\$ 460.00	\$ 498.00	\$ 447.00	\$ 484.00	\$ 421.00	\$ 456.00	\$ 494.00	\$ 415.00	\$ 450.00	\$ 487.00	\$ 423.00	\$ 458.00
40709	Rent Income:FL BUILDING SPACE RENT G/NT	Income	\$ 44,497.00	\$ 3,638.00	\$ 3,649.00	\$ 3,661.00	\$ 3,673.00	\$ 3,687.00	\$ 3,702.00	\$ 3,719.00	\$ 3,736.00	\$ 3,755.00	\$ 3,776.00	\$ 3,799.00	\$ 3,702.00
41019	Rent Income:RENTS & CONCESSIONS M/NT	Income	\$ -												
41108	Rent Income:Rents, Tideland Leases - T	Income	\$ 399,819.00	\$ 34,646.00	\$ 34,855.00	\$ 34,625.00	\$ 35,612.00	\$ 35,908.00	\$ 32,075.00	\$ 32,875.00	\$ 30,590.00	\$ 31,328.00	\$ 32,116.00	\$ 32,172.00	\$ 33,017.00
40218	Rent Income:Slip Rents - T	Income	\$ 630,284.00	\$ 51,696.00	\$ 51,761.00	\$ 51,745.00	\$ 51,754.00	\$ 51,855.00	\$ 52,663.00	\$ 53,636.00	\$ 53,349.00	\$ 52,981.00	\$ 52,857.00	\$ 53,540.00	\$ 52,447.00
41309	Rent Income:Storage - NT	Income	\$ 79,231.00	\$ 6,010.00	\$ 6,227.00	\$ 6,446.00	\$ 6,673.00	\$ 6,921.00	\$ 7,081.00	\$ 7,206.00	\$ 7,024.00	\$ 6,421.00	\$ 6,277.00	\$ 6,404.00	\$ 6,541.00
40318.1	Rent Income:Transient Rentals - T	Income	\$ 20,218.00	\$ 2,007.00	\$ 1,868.00	\$ 1,823.00	\$ 1,566.00	\$ 1,537.00	\$ 1,572.00	\$ 1,648.00	\$ 1,565.00	\$ 1,589.00	\$ 1,650.00	\$ 1,677.00	\$ 1,716.00
41409	Rent Income:Upland Rent - NT	Income	\$ 600,000.00	\$ 50,000.00	\$ 50,000.00	\$ 50,000.00	\$ 50,000.00	\$ 50,000.00	\$ 50,000.00	\$ 50,000.00	\$ 50,000.00	\$ 50,000.00	\$ 50,000.00	\$ 50,000.00	\$ 50,000.00
41409.2	Rent Income:Upland Rent - NT:Redwood Terminal 2 - NMTC	Income	\$ -												
40809	Rent Income:Yard Rent - NT	Income	\$ 38,287.00	\$ 3,143.00	\$ 3,189.00	\$ 3,214.00	\$ 3,243.00	\$ 3,283.00	\$ 3,254.00	\$ 3,222.00	\$ 3,170.00	\$ 3,147.00	\$ 3,101.00	\$ 3,137.00	\$ 3,184.00
	Sales	Income	\$ -												
40119	Sales:Concession Sales - NT	Income	\$ 10,122.00	\$ 798.00	\$ 826.00	\$ 828.00	\$ 845.00	\$ 864.00	\$ 860.00	\$ 896.00	\$ 873.00	\$ 859.00	\$ 804.00	\$ 828.00	\$ 841.00
52708.1	Sales:Discount	Income	\$ 197.00	\$ 17.00	\$ 18.00	\$ 16.00	\$ 15.00	\$ 14.00	\$ 14.00	\$ 16.00	\$ 17.00	\$ 18.00	\$ 20.00	\$ 15.00	\$ 17.00
40118	Sales:SALES & PERMITS M/T	Income	\$ 13,794.00	\$ 982.00	\$ 1,064.00	\$ 1,152.00	\$ 1,248.00	\$ 1,229.00	\$ 1,197.00	\$ 1,184.00	\$ 1,169.00	\$ 1,153.00	\$ 1,146.00	\$ 1,139.00	\$ 1,131.00

Account Number	Accounts	Account Type	Total Budget	\$ 46,204.00	\$ 46,235.00	\$ 46,266.00	\$ 46,296.00	\$ 46,327.00	\$ 46,357.00	\$ 46,388.00	\$ 46,419.00	\$ 46,447.00	\$ 46,478.00	\$ 46,508.00	\$ 46,539.00
40109	Sales:Sales, Retail - NT	Income	\$ -												
	Sales of Product Income	Income	\$ -												
	Services	Income	\$ -												
	Shipping Income	Income	\$ -												
	Tax Revenue	Income	\$ -												
45009	Tax Revenue:Other Federal Tax Revenue	Income	\$ 20.00	\$ 2.00	\$ 2.00	\$ 2.00	\$ 2.00	\$ 1.00	\$ 1.00	\$ 1.00	\$ 1.00	\$ 2.00	\$ 2.00	\$ 2.00	\$ 2.00
43509	Tax Revenue:Property Tax Revenues	Income	\$ 1,515,336.00	\$ 126,278.00	\$ 126,278.00	\$ 126,278.00	\$ 126,278.00	\$ 126,278.00	\$ 126,278.00	\$ 126,278.00	\$ 126,278.00	\$ 126,278.00	\$ 126,278.00	\$ 126,278.00	\$ 126,278.00
	Unapplied Cash Payment Income	Income	\$ -												
4999	UNCATEGORIZED INCOME	Income	\$ -												
	Utility Surcharge	Income	\$ -												
40409	Utility Surcharge:Utility Surcharge - NT	Income	\$ 126,875.00	\$ 11,206.00	\$ 10,589.00	\$ 10,467.00	\$ 11,050.00	\$ 10,760.00	\$ 10,396.00	\$ 10,119.00	\$ 9,796.00	\$ 10,501.00	\$ 11,240.00	\$ 10,126.00	\$ 10,625.00
40418	Utility Surcharge:Utility Surcharge, Marina Dock	Income	\$ 65,141.00	\$ 5,478.00	\$ 5,334.00	\$ 5,430.00	\$ 5,499.00	\$ 5,471.00	\$ 5,843.00	\$ 5,295.00	\$ 5,111.00	\$ 5,445.00	\$ 5,407.00	\$ 5,398.00	\$ 5,430.00
	Total Income		\$ 10,456,729.00	\$ 886,644.00	\$ 930,867.00	\$ 964,566.00	\$ 976,442.00	\$ 881,798.00	\$ 872,163.00	\$ 790,731.00	\$ 790,059.00	\$ 817,308.00	\$ 834,809.00	\$ 839,342.00	\$ 872,000.00
	Cost of Goods Sold	Cost Of Goods Sold	\$ -												
	Accounting/Auditing Services	Expense	\$ -												
52508	Accounting/Auditing Services:Accounting Fees - NT	Expense	\$ 38,307.00	\$ 3,308.00	\$ 3,406.00	\$ 3,054.00	\$ 3,239.00	\$ 3,163.00	\$ 3,116.00	\$ 3,049.00	\$ 3,046.00	\$ 3,111.00	\$ 3,244.00	\$ 3,370.00	\$ 3,201.00
52500	Accounting/Auditing Services:Accounting Fees - T	Expense	\$ 99,858.00	\$ 8,759.00	\$ 8,955.00	\$ 7,778.00	\$ 8,219.00	\$ 8,328.00	\$ 8,090.00	\$ 8,121.00	\$ 8,026.00	\$ 8,128.00	\$ 8,428.00	\$ 8,696.00	\$ 8,330.00
	Advertising & Promotion	Expense	\$ -												
51000	Advertising & Promotion:Advertising & Promotion - NT	Expense	\$ 556.00	\$ 30.00	\$ 10.00	\$ 11.00	\$ 12.00	\$ 98.00	\$ 21.00	\$ 23.00	\$ 107.00	\$ 116.00	\$ 40.00	\$ 43.00	\$ 45.00
51008	Advertising & Promotion:Advertising & Promotion - T	Expense	\$ 731.00	\$ 57.00	\$ 47.00	\$ 51.00	\$ 55.00	\$ 60.00	\$ 65.00	\$ 70.00	\$ 76.00	\$ 83.00	\$ 51.00	\$ 56.00	\$ 60.00
	Bad Debts	Expense	\$ -												
51309	Bad Debts:Bad Debts - NT	Expense	\$ -												
51308	Bad Debts:Bad Debts - T	Expense	\$ 30,731.00	\$ 1,802.00	\$ 1,952.00	\$ 2,115.00	\$ 2,291.00	\$ 2,467.00	\$ 2,673.00	\$ 2,896.00	\$ 3,137.00	\$ 3,398.00	\$ 2,456.00	\$ 2,661.00	\$ 2,883.00
57018	Bank Service Charges	Expense	\$ 4,764.00	\$ 426.00	\$ 419.00	\$ 414.00	\$ 409.00	\$ 403.00	\$ 397.00	\$ 391.00	\$ 383.00	\$ 379.00	\$ 374.00	\$ 369.00	\$ 400.00
	Capital Outlay	Expense	\$ -												
53619	Capital Outlay:Expenses Pending Transfer - Eq	Expense	\$ -												
53608	Capital Outlay:Expenses Pending Transfer - Ves	Expense	\$ -												
53618	Capital Outlay:Expenses Pending Transfer-Auto	Expense	\$ -												
53609	Capital Outlay:Expenses Pending Transfer-Bldg	Expense	\$ 285,000.00	\$ 23,750.00	\$ 23,750.00	\$ 23,750.00	\$ 23,750.00	\$ 23,750.00	\$ 23,750.00	\$ 23,750.00	\$ 23,750.00	\$ 23,750.00	\$ 23,750.00	\$ 23,750.00	\$ 23,750.00
	Communications	Expense	\$ -												
51400	Communications:Communications - NT	Expense	\$ 13,788.00	\$ 1,157.00	\$ 1,157.00	\$ 1,154.00	\$ 1,152.00	\$ 1,151.00	\$ 1,149.00	\$ 1,145.00	\$ 1,142.00	\$ 1,140.00	\$ 1,144.00	\$ 1,147.00	\$ 1,150.00
51408	Communications:Communications - T	Expense	\$ 2,149.00	\$ 178.00	\$ 179.00	\$ 179.00	\$ 180.00	\$ 180.00	\$ 179.00	\$ 179.00	\$ 179.00	\$ 179.00	\$ 179.00	\$ 179.00	\$ 179.00
	Conference & Meetings	Expense	\$ -												
51500	Conference & Meetings:Conferences & Meetings - NT	Expense	\$ 17,254.00	\$ 1,331.00	\$ 1,367.00	\$ 1,429.00	\$ 1,410.00	\$ 1,400.00	\$ 1,360.00	\$ 1,570.00	\$ 1,607.00	\$ 1,646.00	\$ 1,348.00	\$ 1,363.00	\$ 1,423.00
51508	Conference & Meetings:Conferences & Meetings - T	Expense	\$ 114.00	\$ 23.00	\$ 8.00	\$ 9.00	\$ 10.00	\$ 6.00	\$ 6.00	\$ 7.00	\$ 8.00	\$ 8.00	\$ 9.00	\$ 10.00	\$ 10.00
	Depreciation	Expense	\$ -												
53509	Depreciation:Depreciation - NT	Expense	\$ 760,029.00	\$ 65,661.00	\$ 65,279.00	\$ 64,864.00	\$ 64,416.00	\$ 63,929.00	\$ 63,403.00	\$ 62,832.00	\$ 62,214.00	\$ 61,544.00	\$ 60,819.00	\$ 60,033.00	\$ 65,035.00
53508	Depreciation:Depreciation - T	Expense	\$ 49,644.00	\$ 2,565.00	\$ 2,778.00	\$ 3,010.00	\$ 3,261.00	\$ 3,533.00	\$ 3,827.00	\$ 4,146.00	\$ 4,491.00	\$ 4,866.00	\$ 5,271.00	\$ 5,710.00	\$ 6,186.00
	Dredging Expense	Expense	\$ -												
56708	Dredging Expense:Dredging - GT	Expense	\$ 1,853.00	\$ 129.00	\$ 140.00	\$ 151.00	\$ 164.00	\$ 161.00	\$ 158.00	\$ 171.00	\$ 168.00	\$ 182.00	\$ 165.00	\$ 127.00	\$ 137.00
56718	Dredging Expense:Dredging - MT	Expense	\$ (278,757.00)	\$ (14,401.00)	\$ (15,601.00)	\$ (16,902.00)	\$ (18,310.00)	\$ (19,836.00)	\$ (21,489.00)	\$ (23,280.00)	\$ (25,219.00)	\$ (27,321.00)	\$ (29,598.00)	\$ (32,064.00)	\$ (34,736.00)
55608	Dredging Expense:Dredging Expense - T	Expense	\$ 41,319.00	\$ 3,744.00	\$ 4,056.00	\$ 4,394.00	\$ 4,761.00	\$ 5,157.00	\$ 5,517.00	\$ 5,831.00	\$ 6,100.00	\$ 6,329.00	\$ 6,514.00	\$ 6,656.00	\$ 6,756.00
	Dues, Subscriptions & Licences	Expense	\$ -												
51600	Dues, Subscriptions & Licences:Dues & Subscriptions - NT	Expense	\$ 36,147.00	\$ 3,218.00	\$ 3,157.00	\$ 3,256.00	\$ 3,299.00	\$ 2,887.00	\$ 3,104.00	\$ 2,631.00	\$ 2,790.00	\$ 3,006.00	\$ 3,012.00	\$ 2,778.00	\$ 3,009.00
51608	Dues, Subscriptions & Licences:Dues & Subscriptions - T	Expense	\$ 10,961.00	\$ 755.00	\$ 713.00	\$ 772.00	\$ 836.00	\$ 906.00	\$ 961.00	\$ 947.00	\$ 1,026.00	\$ 1,112.00	\$ 1,205.00	\$ 829.00	\$ 899.00
	Elections & Government Fees	Expense	\$ -												
51708	Elections & Government Fees:Elections & Prop Tax Assess - T	Expense	\$ -												
51700	Elections & Government Fees:Elections & Prop Tax Assess-NT	Expense	\$ 27,107.00	\$ 2,181.00	\$ 2,362.00	\$ 2,559.00	\$ 2,772.00	\$ 2,625.00	\$ 2,843.00	\$ 1,597.00	\$ 1,730.00	\$ 1,874.00	\$ 2,030.00	\$ 2,176.00	\$ 2,358.00
	Engineering Services	Expense	\$ -												
52400	Engineering Services:Engineering Fees - NT	Expense	\$ 74,567.00	\$ 3,637.00	\$ 11,910.00	\$ 12,518.00	\$ 4,839.00	\$ 4,884.00	\$ 4,531.00	\$ 4,851.00	\$ 5,093.00	\$ 5,346.00	\$ 5,374.00	\$ 5,560.00	\$ 6,024.00
52408	Engineering Services:Engineering Fees - T	Expense	\$ 7,328.00	\$ 629.00	\$ 681.00	\$ 738.00	\$ 774.00	\$ 802.00	\$ 679.00	\$ 409.00	\$ 443.00	\$ 480.00	\$ 520.00	\$ 563.00	\$ 610.00
55700	Float Replacement Expense - MT	Expense	\$ -												
	Fuel	Expense	\$ -												
51218	Fuel:Automotive, Fuel - T	Expense	\$ 6,171.00	\$ 593.00	\$ 512.00	\$ 513.00	\$ 502.00	\$ 500.00	\$ 501.00	\$ 502.00	\$ 502.00	\$ 502.00	\$ 547.00	\$ 477.00	\$ 517.00
51200	Fuel:Automotive, Fuel- NT	Expense	\$ 9,447.00	\$ 796.00	\$ 732.00	\$ 751.00	\$ 760.00	\$ 780.00	\$ 803.00	\$ 830.00	\$ 823.00	\$ 801.00	\$ 833.00	\$ 755.00	\$ 783.00
51208	Fuel:Vessel Fuel	Expense	\$ 1,184.00	\$ 98.00	\$ 82.00	\$ 89.00	\$ 97.00	\$ 105.00	\$ 113.00	\$ 85.00	\$ 92.00	\$ 100.00	\$ 108.00	\$ 117.00	\$ 98.00
	Grant Expenses	Expense	\$ -												
	Grant Expenses:Conservation Grant Expenses	Expense	\$ -												
50500.3	Grant Expenses:Conservation Grant Expenses:Conservation Grant - Payroll Be	Expense	\$ -												
50100.3	Grant Expenses:Conservation Grant Expenses:Conservation Grant - Wages	Expense	\$ -												
54408.3	Grant Expenses:Conservation Grant Expenses:Conservation Grant Exp	Expense	\$ 2,965.00	\$ 487.00	\$ 400.00	\$ 246.00	\$ 208.00	\$ 158.00	\$ 163.00	\$ 176.00	\$ 191.00	\$ 207.00	\$ 224.00	\$ 242.00	\$ 263.00
	Grant Expenses:Harbor Grant Expenses	Expense	\$ -												
54408.1	Grant Expenses:Harbor Grant Expenses:Harbor Grant Exp	Expense	\$ (255,817.00)	\$ 7,693.00	\$ 8,263.00	\$ (14,457.00)	\$ (69,060.00)	\$ (75,008.00)	\$ (4,958.00)	\$ (7,129.00)	\$ (7,857.00)	\$ (10,678.00)	\$ (18,771.00)	\$ (26,812.00)	\$ (37,043.00)
50500.1	Grant Expenses:Harbor Grant Expenses:Harbor Grant Expenses - Payroll	Expense	\$ -												
50100.1	Grant Expenses:Harbor Grant Expenses:Harbor Grant Expenses - Wages	Expense	\$ -												
50110.1	Grant Expenses:Harbor Grant Expenses:Salaries&Wages M/A Harbor Grant	Expense	\$ -												
55000	Grant Expenses:Overhead - Grant	Expense	\$ -												
	Grant Expenses:Recreation Grant Expenses	Expense	\$ -												
54408.2	Grant Expenses:Recreation Grant Expenses:Recreation Grant Exp	Expense	\$ 3,152.00	\$ 163.00	\$ 176.00	\$ 191.00	\$ 207.00	\$ 224.00	\$ 243.00	\$ 263.00	\$ 285.00	\$ 309.00	\$ 335.00	\$ 363.00	\$ 393.00
50400	Imputed Auto Value	Expense	\$ -												
	Insurance	Expense	\$ -												

Account Number	Accounts	Account Type	Total Budget	\$ 46,204.00	\$ 46,235.00	\$ 46,266.00	\$ 46,296.00	\$ 46,327.00	\$ 46,357.00	\$ 46,388.00	\$ 46,419.00	\$ 46,447.00	\$ 46,478.00	\$ 46,508.00	\$ 46,539.00
51800	Insurance:Insurance - NT	Expense	\$ 131,336.00	\$ 11,824.00	\$ 11,347.00	\$ 10,962.00	\$ 10,710.00	\$ 10,558.00	\$ 10,504.00	\$ 10,539.00	\$ 10,723.00	\$ 10,798.00	\$ 10,995.00	\$ 10,842.00	\$ 11,534.00
51808	Insurance:Insurance - T	Expense	\$ 10,575.00	\$ 1,833.00	\$ 1,985.00	\$ 459.00	\$ 497.00	\$ 539.00	\$ 584.00	\$ 632.00	\$ 685.00	\$ 742.00	\$ 804.00	\$ 871.00	\$ 944.00
51810	Insurance:INSURANCE M/A	Expense	\$ -	\$ -	\$ -	\$ -	\$ -	\$ -	\$ -	\$ -	\$ -	\$ -	\$ -	\$ -	
51819	Insurance:INSURANCE M/NT	Expense	\$ -	\$ -	\$ -	\$ -	\$ -	\$ -	\$ -	\$ -	\$ -	\$ -	\$ -	\$ -	
53109.3	Insurance:INSURANCE M/NT:Fields Landing Insurance	Expense	\$ -	\$ -	\$ -	\$ -	\$ -	\$ -	\$ -	\$ -	\$ -	\$ -	\$ -	\$ -	
53209.1	Insurance:INSURANCE M/NT:Shelter Cove Insurance	Expense	\$ -	\$ -	\$ -	\$ -	\$ -	\$ -	\$ -	\$ -	\$ -	\$ -	\$ -	\$ -	
	Interest Expense	Expense	\$ -	\$ -	\$ -	\$ -	\$ -	\$ -	\$ -	\$ -	\$ -	\$ -	\$ -	\$ -	
55109	Interest Expense:Interest Expense - NT	Expense	\$ 187,687.00	\$ 15,490.00	\$ 16,127.00	\$ 16,816.00	\$ 17,451.00	\$ 18,154.00	\$ 16,407.00	\$ 13,301.00	\$ 13,725.00	\$ 14,214.00	\$ 14,744.00	\$ 15,318.00	\$ 15,940.00
55108	Interest Expense:Interest Expense - T	Expense	\$ 72,215.00	\$ 6,004.00	\$ 6,147.00	\$ 6,303.00	\$ 6,472.00	\$ 6,654.00	\$ 5,464.00	\$ 5,563.00	\$ 5,670.00	\$ 5,786.00	\$ 5,911.00	\$ 6,047.00	\$ 6,194.00
	Legal Services	Expense	\$ -	\$ -	\$ -	\$ -	\$ -	\$ -	\$ -	\$ -	\$ -	\$ -	\$ -	\$ -	
52300	Legal Services:Legal Fees - NT	Expense	\$ 93,565.00	\$ 7,056.00	\$ 7,120.00	\$ 7,521.00	\$ 7,879.00	\$ 6,720.00	\$ 7,045.00	\$ 7,508.00	\$ 7,915.00	\$ 8,353.00	\$ 8,948.00	\$ 9,693.00	\$ 7,807.00
52308	Legal Services:Legal Fees - T	Expense	\$ 17,984.00	\$ 1,159.00	\$ 1,239.00	\$ 1,293.00	\$ 1,379.00	\$ 1,454.00	\$ 1,541.00	\$ 1,628.00	\$ 1,706.00	\$ 1,801.00	\$ 1,922.00	\$ 1,393.00	\$ 1,469.00
	Maintenance - Equipment	Expense	\$ -	\$ -	\$ -	\$ -	\$ -	\$ -	\$ -	\$ -	\$ -	\$ -	\$ -	\$ -	
51209	Maintenance - Equipment:Automotive, Repairs - NT	Expense	\$ 7,252.00	\$ 559.00	\$ 576.00	\$ 614.00	\$ 581.00	\$ 562.00	\$ 579.00	\$ 618.00	\$ 628.00	\$ 626.00	\$ 675.00	\$ 636.00	\$ 598.00
52710	Maintenance - Equipment:Repairs & Maint, Equip - NT	Expense	\$ 10,407.00	\$ 676.00	\$ 729.00	\$ 796.00	\$ 863.00	\$ 920.00	\$ 970.00	\$ 1,048.00	\$ 971.00	\$ 1,018.00	\$ 782.00	\$ 785.00	\$ 849.00
52718	Maintenance - Equipment:Repairs & Maint, Equip - T	Expense	\$ 33,226.00	\$ 2,891.00	\$ 2,485.00	\$ 2,557.00	\$ 2,682.00	\$ 2,788.00	\$ 3,026.00	\$ 3,276.00	\$ 3,540.00	\$ 2,292.00	\$ 2,377.00	\$ 2,550.00	\$ 2,762.00
	Maintenance - Facilities	Expense	\$ -	\$ -	\$ -	\$ -	\$ -	\$ -	\$ -	\$ -	\$ -	\$ -	\$ -	\$ -	
54309	Maintenance - Facilities:Redwood Terminal 2 Expenses	Expense	\$ -	\$ -	\$ -	\$ -	\$ -	\$ -	\$ -	\$ -	\$ -	\$ -	\$ -	\$ -	
52719	Maintenance - Facilities:Repairs & Maint, Facilities - N	Expense	\$ 46,160.00	\$ 3,541.00	\$ 3,629.00	\$ 3,798.00	\$ 4,058.00	\$ 4,111.00	\$ 4,076.00	\$ 3,584.00	\$ 3,681.00	\$ 3,885.00	\$ 4,075.00	\$ 3,880.00	\$ 3,842.00
52708	Maintenance - Facilities:Repairs & Maint, Facilities - T	Expense	\$ 82,428.00	\$ 7,311.00	\$ 7,110.00	\$ 7,418.00	\$ 7,837.00	\$ 6,283.00	\$ 6,581.00	\$ 6,889.00	\$ 6,212.00	\$ 6,517.00	\$ 6,882.00	\$ 6,513.00	\$ 6,875.00
	Maintenance - IT	Expense	\$ -	\$ -	\$ -	\$ -	\$ -	\$ -	\$ -	\$ -	\$ -	\$ -	\$ -	\$ -	
57009	Maintenance - IT:Maintenance, IT Equip - NT	Expense	\$ 6,573.00	\$ 507.00	\$ 525.00	\$ 544.00	\$ 540.00	\$ 560.00	\$ 607.00	\$ 608.00	\$ 634.00	\$ 469.00	\$ 508.00	\$ 526.00	\$ 545.00
57008	Maintenance - IT:Maintenance, IT Equip - T	Expense	\$ 7,550.00	\$ 638.00	\$ 635.00	\$ 650.00	\$ 622.00	\$ 617.00	\$ 655.00	\$ 608.00	\$ 621.00	\$ 635.00	\$ 622.00	\$ 617.00	\$ 630.00
	Maintenance Supplies	Expense	\$ -	\$ -	\$ -	\$ -	\$ -	\$ -	\$ -	\$ -	\$ -	\$ -	\$ -	\$ -	
52010	Maintenance Supplies:Maintenance Supplies - NT	Expense	\$ 27,504.00	\$ 2,166.00	\$ 2,253.00	\$ 2,245.00	\$ 2,247.00	\$ 2,224.00	\$ 2,300.00	\$ 2,334.00	\$ 2,363.00	\$ 2,450.00	\$ 2,347.00	\$ 2,294.00	\$ 2,281.00
52008	Maintenance Supplies:Maintenance Supplies - T	Expense	\$ 1,202.00	\$ 94.00	\$ 102.00	\$ 110.00	\$ 120.00	\$ 78.00	\$ 84.00	\$ 91.00	\$ 99.00	\$ 102.00	\$ 110.00	\$ 113.00	\$ 99.00
53200	Maintenance Supplies:SHELTER COVE OPER EXP G/A	Expense	\$ -	\$ -	\$ -	\$ -	\$ -	\$ -	\$ -	\$ -	\$ -	\$ -	\$ -	\$ -	
53209	Maintenance Supplies:SHELTER COVE OPER EXP G/NT	Expense	\$ -	\$ -	\$ -	\$ -	\$ -	\$ -	\$ -	\$ -	\$ -	\$ -	\$ -	\$ -	
	Office Supplies	Expense	\$ -	\$ -	\$ -	\$ -	\$ -	\$ -	\$ -	\$ -	\$ -	\$ -	\$ -	\$ -	
51900	Office Supplies:Office Supplies - NT	Expense	\$ 67,467.00	\$ 5,913.00	\$ 5,896.00	\$ 5,807.00	\$ 5,616.00	\$ 5,578.00	\$ 5,491.00	\$ 5,540.00	\$ 5,448.00	\$ 5,501.00	\$ 5,492.00	\$ 5,544.00	\$ 5,641.00
51908	Office Supplies:Office Supplies - T	Expense	\$ 6,005.00	\$ 508.00	\$ 518.00	\$ 499.00	\$ 512.00	\$ 533.00	\$ 511.00	\$ 509.00	\$ 464.00	\$ 481.00	\$ 488.00	\$ 482.00	\$ 500.00
55408	Office Supplies:Other Expenses - T	Expense	\$ -	\$ -	\$ -	\$ -	\$ -	\$ -	\$ -	\$ -	\$ -	\$ -	\$ -	\$ -	
52100	Office Supplies:Outside Services - NT	Expense	\$ 7.00	\$ 1.00	\$ 1.00	\$ -	\$ -	\$ -	\$ -	\$ -	\$ 1.00	\$ 1.00	\$ 1.00	\$ 1.00	\$ 1.00
	Other Expenses	Expense	\$ -	\$ -	\$ -	\$ -	\$ -	\$ -	\$ -	\$ -	\$ -	\$ -	\$ -	\$ -	
53709	Other Expenses:Cash Over/Short - NT	Expense	\$ (100.00)	\$ (8.00)	\$ (9.00)	\$ (10.00)	\$ (11.00)	\$ (12.00)	\$ (12.00)	\$ (5.00)	\$ (5.00)	\$ (6.00)	\$ (6.00)	\$ (8.00)	\$ (8.00)
54406	Other Expenses:Other Expenses - Felgrass	Expense	\$ 366,633.00	\$ 21,030.00	\$ 22,783.00	\$ 24,682.00	\$ 26,738.00	\$ 28,967.00	\$ 31,381.00	\$ 33,996.00	\$ 36,829.00	\$ 39,898.00	\$ 43,222.00	\$ 27,411.00	\$ 29,696.00
55419	Other Expenses:Other Expenses - NT	Expense	\$ 4,057.00	\$ 455.00	\$ 316.00	\$ 321.00	\$ 348.00	\$ 377.00	\$ 321.00	\$ 347.00	\$ 376.00	\$ 264.00	\$ 286.00	\$ 310.00	\$ 336.00
54405	Other Expenses:Other Expenses - Spartina	Expense	\$ 533,398.00	\$ 48,397.00	\$ 52,430.00	\$ 45,467.00	\$ 47,712.00	\$ 49,356.00	\$ 58,481.00	\$ 40,227.00	\$ 32,668.00	\$ 35,227.00	\$ 38,162.00	\$ 40,930.00	\$ 44,341.00
55418	Other Expenses:Other Expenses - T	Expense	\$ 5,890.00	\$ 342.00	\$ 371.00	\$ 402.00	\$ 435.00	\$ 472.00	\$ 511.00	\$ 554.00	\$ 600.00	\$ 650.00	\$ 516.00	\$ 560.00	\$ 477.00
54109	Other Expenses:Sea Scouts Expense - NT	Expense	\$ -	\$ -	\$ -	\$ -	\$ -	\$ -	\$ -	\$ -	\$ -	\$ -	\$ -	\$ -	
	Other Professional/Outside Serv	Expense	\$ -	\$ -	\$ -	\$ -	\$ -	\$ -	\$ -	\$ -	\$ -	\$ -	\$ -	\$ -	
52110	Other Professional/Outside Serv:OUTSIDE SERVICES M/A	Expense	\$ -	\$ -	\$ -	\$ -	\$ -	\$ -	\$ -	\$ -	\$ -	\$ -	\$ -	\$ -	
52109	Other Professional/Outside Serv:Outside Services, Other - NT	Expense	\$ 28,331.00	\$ 2,479.00	\$ 2,646.00	\$ 2,715.00	\$ 2,271.00	\$ 2,347.00	\$ 2,409.00	\$ 2,208.00	\$ 2,277.00	\$ 2,301.00	\$ 2,138.00	\$ 2,179.00	\$ 2,361.00
52118	Other Professional/Outside Serv:Outside Services, Other - T	Expense	\$ 2,580.00	\$ 229.00	\$ 248.00	\$ 268.00	\$ 291.00	\$ 161.00	\$ 174.00	\$ 188.00	\$ 204.00	\$ 221.00	\$ 183.00	\$ 198.00	\$ 215.00
	Payroll Expenses	Expense	\$ -	\$ -	\$ -	\$ -	\$ -	\$ -	\$ -	\$ -	\$ -	\$ -	\$ -	\$ -	
	Payroll Expenses:Company Contributions	Expense	\$ -	\$ -	\$ -	\$ -	\$ -	\$ -	\$ -	\$ -	\$ -	\$ -	\$ -	\$ -	
	Payroll Expenses:Company Contributions:Retirement	Expense	\$ -	\$ -	\$ -	\$ -	\$ -	\$ -	\$ -	\$ -	\$ -	\$ -	\$ -	\$ -	
	Payroll Expenses:Taxes	Expense	\$ -	\$ -	\$ -	\$ -	\$ -	\$ -	\$ -	\$ -	\$ -	\$ -	\$ -	\$ -	
	Payroll Expenses:Wages	Expense	\$ -	\$ -	\$ -	\$ -	\$ -	\$ -	\$ -	\$ -	\$ -	\$ -	\$ -	\$ -	
	Permits	Expense	\$ -	\$ -	\$ -	\$ -	\$ -	\$ -	\$ -	\$ -	\$ -	\$ -	\$ -	\$ -	
51610	Permits:Permits - NT	Expense	\$ 14,899.00	\$ 1,313.00	\$ 1,423.00	\$ 1,521.00	\$ 1,648.00	\$ 1,785.00	\$ 841.00	\$ 911.00	\$ 987.00	\$ 992.00	\$ 1,075.00	\$ 1,164.00	\$ 1,239.00
51618	Permits:Permits - T	Expense	\$ 2,884.00	\$ 261.00	\$ 283.00	\$ 307.00	\$ 332.00	\$ 360.00	\$ 149.00	\$ 161.00	\$ 175.00	\$ 189.00	\$ 205.00	\$ 222.00	\$ 240.00
	Personnel Expenses	Expense	\$ -	\$ -	\$ -	\$ -	\$ -	\$ -	\$ -	\$ -	\$ -	\$ -	\$ -	\$ -	
	Personnel Expenses:Commissioners Fees	Expense	\$ -	\$ -	\$ -	\$ -	\$ -	\$ -	\$ -	\$ -	\$ -	\$ -	\$ -	\$ -	
50200	Personnel Expenses:Commissioners Fees:Commissioner's Salaries - NT	Expense	\$ -	\$ -	\$ -	\$ -	\$ -	\$ -	\$ -	\$ -	\$ -	\$ -	\$ -	\$ -	
50208	Personnel Expenses:Commissioners Fees:Commissioner's Salaries - T	Expense	\$ -	\$ -	\$ -	\$ -	\$ -	\$ -	\$ -	\$ -	\$ -	\$ -	\$ -	\$ -	
	Personnel Expenses:Contract Temporary Services	Expense	\$ -	\$ -	\$ -	\$ -	\$ -	\$ -	\$ -	\$ -	\$ -	\$ -	\$ -	\$ -	
50310	Personnel Expenses:Contract Temporary Services:Contract Temporary Services - N	Expense	\$ 77,374.00	\$ 4,467.00	\$ 4,839.00	\$ 5,242.00	\$ 5,679.00	\$ 6,152.00	\$ 6,665.00	\$ 7,220.00	\$ 7,809.00	\$ 8,039.00	\$ 7,891.00	\$ 7,102.00	\$ 6,269.00
50318	Personnel Expenses:Contract Temporary Services:Contract Temporary Services - T	Expense	\$ -	\$ -	\$ -	\$ -	\$ -	\$ -	\$ -	\$ -	\$ -	\$ -	\$ -	\$ -	
	Personnel Expenses:Payroll Burden	Expense	\$ -	\$ -	\$ -	\$ -	\$ -	\$ -	\$ -	\$ -	\$ -	\$ -	\$ -	\$ -	
50510	Personnel Expenses:Payroll Burden:PAYROLL BENEFITS M/A	Expense	\$ -	\$ -	\$ -	\$ -	\$ -	\$ -	\$ -	\$ -	\$ -	\$ -	\$ -	\$ -	
50500	Personnel Expenses:Payroll Burden:Payroll Benefits, Other - NT	Expense	\$ 452,775.00	\$ 37,724.00	\$ 37,850.00	\$ 38,025.00	\$ 37,822.00	\$ 37,645.00	\$ 37,793.00	\$ 37,800.00	\$ 37,335.00	\$ 37,544.00	\$ 37,533.00	\$ 37,710.00	\$ 37,994.00
50508	Personnel Expenses:Payroll Burden:Payroll Benefits, Other - T	Expense	\$ 118,863.00	\$ 9,874.00	\$ 10,053.00	\$ 10,087.00	\$ 10,023.00	\$ 9,742.00	\$ 9,780.00	\$ 9,764.00	\$ 9,772.00	\$ 9,836.00	\$ 9,903.00	\$ 9,960.00	\$ 10,069.00
6560	Personnel Expenses:Payroll Burden:Workers' Comp	Expense	\$ 37,258.00	\$ 2,764.00	\$ 2,466.00	\$ 2,320.00	\$ 3,588.00	\$ 3,541.00	\$ 3,489.00	\$ 3,443.00	\$ 3,177.00	\$ 3,151.00	\$ 3,125.00	\$ 3,108.00	\$ 3,086.00
	Personnel Expenses:Salaries/Wages	Expense	\$ -	\$ -	\$ -	\$ -	\$ -	\$ -	\$ -	\$ -	\$ -	\$ -	\$ -	\$ -	
50119	Personnel Expenses:Salaries/Wages:Sal. & Wages, Part-time - NT	Expense	\$ -	\$ -	\$ -	\$ -	\$ -	\$ -	\$ -	\$ -	\$ -	\$ -	\$ -	\$ -	
50118	Personnel Expenses:Salaries/Wages:Sal. & Wages, Part-time - T	Expense	\$ -	\$ -	\$ -	\$ -	\$ -	\$ -	\$ -	\$ -	\$ -	\$ -	\$ -	\$ -	
50100	Personnel Expenses:Salaries/Wages:Salaries & Wages - NT	Expense	\$ 1,099,779.00	\$ 94,284.00	\$ 91,464.00	\$ 91,753.00	\$ 91,770.00	\$ 92,221.00	\$ 92,701.00	\$ 93,177.00	\$ 89,194.00	\$ 89,724.00	\$ 90,396.00	\$ 91,165.00	\$ 91,930.00
50108	Personnel Expenses:Salaries/Wages:Salaries & Wages - T	Expense	\$ (200.00)	\$ -	\$ -	\$ -	\$ -	\$ -	\$ -	\$ -	\$ (146.00)	\$ (12.00)	\$ (13.00)	\$ (14.00)	\$ (15.00)
50105	Personnel Expenses:Salaries/Wages:Wages - Less Spartina Wages	Expense	\$ -	\$ -	\$ -	\$ -	\$ -	\$ -	\$ -	\$ -	\$ -	\$ -	\$ -	\$ -	
	Planning Services	Expense	\$ -	\$ -	\$ -	\$ -	\$ -	\$ -	\$ -	\$ -	\$ -	\$ -	\$ -	\$ -	
52200	Planning Services:Planning Fees - NT	Expense	\$ 25,632.00	\$ 168.00	\$ 1,891.00	\$ 1,875.00	\$ 1,863.00	\$ 1,764.00							

Account Number	Accounts	Account Type	Total Budget	\$ 46,204.00	\$ 46,235.00	\$ 46,266.00	\$ 46,296.00	\$ 46,327.00	\$ 46,357.00	\$ 46,388.00	\$ 46,419.00	\$ 46,447.00	\$ 46,478.00	\$ 46,508.00	\$ 46,539.00
52208	Planning Services:Planning Fees - T	Expense	\$ 28,196.00	\$ 2,846.00	\$ 1,997.00	\$ 2,152.00	\$ 2,215.00	\$ 2,290.00	\$ 2,316.00	\$ 2,182.00	\$ 2,350.00	\$ 2,546.00	\$ 2,460.00	\$ 2,471.00	\$ 2,371.00
	Purchases	Expense	\$ -												
Q66900	QReconciliation Discrepancies	Expense	\$ -												
	Rent Expense	Expense	\$ -												
54409	Rent Expense:Lease Expense - RT2	Expense	\$ -												
54308	Rent Expense:Redwood Terminal 2 Lease Expen	Expense	\$ -												
52600	Rent Expense:Rent Expense - NT	Expense	\$ 2,499.00	\$ 163.00	\$ 177.00	\$ 192.00	\$ 208.00	\$ 225.00	\$ 244.00	\$ 264.00	\$ 221.00	\$ 239.00	\$ 174.00	\$ 188.00	\$ 204.00
	Small Tools	Expense	\$ -												
52800	Small Tools:Small Tools - NT	Expense	\$ 1,747.00	\$ 186.00	\$ 181.00	\$ 118.00	\$ 128.00	\$ 129.00	\$ 137.00	\$ 149.00	\$ 132.00	\$ 143.00	\$ 155.00	\$ 139.00	\$ 150.00
52808	Small Tools:Small Tools - T	Expense	\$ 41.00	\$ 11.00	\$ 2.00	\$ 2.00	\$ 2.00	\$ 2.00	\$ 2.00	\$ 3.00	\$ 3.00	\$ 3.00	\$ 3.00	\$ 4.00	\$ 4.00
	Unapplied Cash Bill Payment Expense	Expense	\$ -												
	Uncategorized Expense	Expense	\$ -												
	Utilities	Expense	\$ -												
52909	Utilities:Utilities - NT	Expense	\$ 263,827.00	\$ 23,020.00	\$ 22,513.00	\$ 21,581.00	\$ 22,076.00	\$ 22,041.00	\$ 22,703.00	\$ 21,449.00	\$ 21,575.00	\$ 21,197.00	\$ 22,025.00	\$ 21,575.00	\$ 22,072.00
52918	Utilities:Utilities - T	Expense	\$ 95,927.00	\$ 7,711.00	\$ 8,354.00	\$ 7,994.00	\$ 8,660.00	\$ 8,677.00	\$ 9,158.00	\$ 7,765.00	\$ 7,849.00	\$ 7,413.00	\$ 7,065.00	\$ 7,335.00	\$ 7,946.00
53000	Utilities:Water, Sewer, & Refuse - NT	Expense	\$ 136,201.00	\$ 11,487.00	\$ 11,458.00	\$ 11,515.00	\$ 11,308.00	\$ 11,275.00	\$ 11,511.00	\$ 11,365.00	\$ 11,212.00	\$ 11,266.00	\$ 11,450.00	\$ 11,001.00	\$ 11,353.00
53008	Utilities:Water, Sewer, & Refuse - T	Expense	\$ 75,185.00	\$ 6,118.00	\$ 6,189.00	\$ 6,295.00	\$ 6,201.00	\$ 6,213.00	\$ 6,279.00	\$ 6,349.00	\$ 6,426.00	\$ 6,303.00	\$ 6,289.00	\$ 6,263.00	\$ 6,260.00
	Total Expense		\$ 5,173,371.00	\$ 462,261.00	\$ 475,239.00	\$ 445,853.00	\$ 391,626.00	\$ 386,876.00	\$ 462,991.00	\$ 439,186.00	\$ 429,664.00	\$ 432,839.00	\$ 430,878.00	\$ 407,315.00	\$ 408,643.00
55409	OTHER EXPENSES G/NT	Other Expense	\$ (67,404.00)	\$ -	\$ -	\$ (1,818.00)	\$ (2,534.00)	\$ (3,833.00)	\$ (4,153.00)	\$ (5,887.00)	\$ (8,263.00)	\$ (12,347.00)	\$ (18,598.00)	\$ (4,786.00)	\$ (5,185.00)
	Other Non-operating Expenses	Other Expense	\$ -												
	Reconciliation Discrepancies	Other Expense	\$ -												
	Total Other Expense		\$ (67,404.00)	\$ -	\$ -	\$ (1,818.00)	\$ (2,534.00)	\$ (3,833.00)	\$ (4,153.00)	\$ (5,887.00)	\$ (8,263.00)	\$ (12,347.00)	\$ (18,598.00)	\$ (4,786.00)	\$ (5,185.00)
	Net Profit		\$ 5,350,762.00	\$ 424,383.00	\$ 455,628.00	\$ 520,531.00	\$ 587,350.00	\$ 498,755.00	\$ 413,325.00	\$ 357,432.00	\$ 368,658.00	\$ 396,816.00	\$ 422,529.00	\$ 436,813.00	\$ 468,542.00